



2m ALL MODE TRANSCEIVER

Model TS-700SP



OPERATING MANUAL

CONTENTS

SECTION

SPECIFICATIONS	3
1. FEATURES	4
2. INSTALLATION	5
2-1. Accessories	5
2-2. Operating Location	5
2-3. Power Supply Connection	5
2-4. Antenna Connection	5
2-5. Microphone	5
2-6. Key	5
2-7. External Speaker	6
2-8. MIC Hook	6
3. OPERATING CONTROLS	7
3-1. Front Panel Controls and Connectors	7
3-2. Internal Controls	9
3-3. Rear Panel Controls	10
4. OPERATING INSTRUCTIONS	11
4-1. Reception	11
4-2. Transmission	12
4-3. R-DX (Receive Pre-Amp)	14
4-4. RIT (Receiver Incremental Tuning)	14
4-5. NB (Noise Blanker)	14
4-6. RF Gain	14
4-7. Low Power Setting	14
4-8. Reading Operating Frequencies	15
4-9. Sub-Dial	15
4-10. Tone Pad Input	15
4-11. 7th Digit Display (FM)	15
4-12. VOX Operation	15
4-13. Semi-Break-In Operation	16
4-14. Fixed Channel Operation	16
4-15. Mobile Operation (DC Power)	17
4-16. Repeater Operation	17
4-17. OSCAR (Satellite) Operation	18
5. BLOCK DIAGRAM	19
5-1. Block Diagram	20
6. ACCESSORIES	21
6-1. Accessories	21
6-2. To Connect the VFO-700S	21
7. ALIGNMENT	22
7-1. General Information	22
7-2. Ordering Spare Parts	23
8. TROUBLESHOOTING	24
PACKING FOR SHIPMENT	25
TOP & BOTTOM INTERNAL VIEWS	26

SPECIFICATIONS

GENERAL

Frequency Range	144.0 to 148.0
Mode	SSB (USB, LSB), CW, AM, FM
Antenna Impedance	50 Ohms
Frequency Stability	Within ± 3 kHz during one hour after one minute Warm-up, and within 150 Hz during any 30 minute period thereafter.
Semiconductors	Transistors: 108, FETs: 19, ICs: 20, Diodes: 171
Voltage Requirements	120/220V AC, 50/60 Hz: 12.0 to 16.0V DC (13.8V DC nominal)
Power Consumption	Transmit: 98 Watts (120/220V AC) 4.0A (13.8V DC) Receive (no signal): 48 Watts (120/220V AC), 1.2A (13.8V DC)
Dimensions	278 mm wide \times 124 mm high \times 320 mm deep (10-7/8" \times 4-7/8" \times 12-5/8")
Weight	11.0 kg (24.2 lbs)

TRANSMITTER

RF Power Output	SSB, FM, CW: 10 Watts AM: 3 Watts FM Low: Approx. 1 Watt
Modulation	SSB: Balanced modulation FM: Variable reactance frequency shift AM: Low power modulation
Maximum Frequency Deviation (FM)	± 5 kHz
Carrier Suppression	Better than 40 dB
Sideband Suppression	Better than 40 dB
Spurious Radiation	Better than -60 dB
Microphone Impedance	Low impedance (500 Ohms)
AF Response	400 to 2,600 Hz
Repeater Offset	600 kHz
Tone Burst Duration	0.5 to 1.0 Sec.

RECEIVER

Sensitivity	SSB and CW: $0.25 \mu\text{V}$ for 10 dB (S+N)/N AM: $1.0 \mu\text{V}$ for 10 dB (S+N)/N FM: $0.4 \mu\text{V}$ for 20 dB noise quieting $1.0 \mu\text{V}$ for 30 dB (S+N)/N
Selectivity	SSB, CW and AM: 2.4 kHz/ -6 dB, 4.8 kHz/ -60 dB FM: 12 kHz/ -6 dB, 24 kHz/ -60 dB
Intermediate Frequency	SSB, CW and AM: 10.7 MHz FM: 1st 10.7 MHz, 2nd 455 kHz
Image Rejection	Better than 70 dB
IF Rejection	Better than 70 dB
Squelch Sensitivity	$0.25 \mu\text{V}$
AF Output Power	2 Watts/8 Ohm at less than 10% distortion
AF Output Impedance	8 Ohms

Specifications are subject to change without notice for technical improvement.

SECTION 1. FEATURES

1. The Model TS-700SP is a fully solid-state, 2 meter all-mode amateur band transceiver, designed to provide high quality communications an SSB, FM, AM or CW.
2. A built-in digital frequency counter provides:
 - Direct frequency readout precise to 100 Hz, in seven digits.
 - Blue fluorescent display.
 - Display of actual operating frequency, any mode.
 - Display of your actual operating frequency when using the VFO-700S external VFO.
3. The TS-700SP is designed for both fixed station or mobile operation, and has self contained AC and DC power supplies.
4. The transceiver incorporates its own built-in VFO that continuously covers the frequency range of 144.00 to 148.00 MHz in 4 bands. Repeater operation is possible in the 145, 146 and 147 MHz bands. The repeater frequency is shifted at both NORMAL and REVERSE positions of the repeater control knob.
5. The TS-700SP is equipped with a dual vernier tuning control consisting of one control that provides bandspread tuning at 25 kHz per turn, and the other provides tuning at 100 kHz per turn. This assures maximum convenience when rapid tuning is needed, plus bandspread tuning, so important in SSB reception.
6. 11 fixed frequency crystal positions give you a total of 44 fixed channels (11 on each band).
7. A noise blanker (NB) circuit is included to eliminate pulse and ignition noise.
8. For FM operation, a squelch circuit consisting of a noise detector and Schmidt trigger is incorporated.
9. The receiver RF stage uses voltage-variable capacitors (varicaps) for tuning to minimize cross-talk and spurious interference. It employs high "Q" antenna input circuits (Helical Resonators) for excellent selectivity.
10. A FET balanced mixer is used for the pre-mixer and heterodyne mixer for excellent spurious rejection during transmission.
11. The repeater frequency for transmission or reception can be inverted (NORMAL — REVERSE) with one control. The tone burst generator permits the automatic activation of a repeater circuit (FM-mode only).
12. The IF stage includes a 6-element crystal filter. Built-in ceramic filters provide outstanding selectivity during FM reception.
13. The threshold type RF gain control assures excellent S/N ratio at all times during SSB reception.
14. An amplified AGC circuit is used; the time constant is automatically selected by the mode switch. The AGC is "slow" in the SSB mode and "fast" in the FM, AM and CW modes.
15. An amplified ALC circuit is used to reduce distortion of the transmitted signal.
16. The unique S-meter circuit (patent pending) provides an accurate indication of the received signal strength without "scale-out" even with unusually strong FM signals.
17. A convenient low power selector is available for local communications.
18. Semi-break-in CW operation with side tone.
19. Operates on either 120/220V AC or 13.8V DC.
20. Built-in VOX.
21. Remote VFO operation is possible with the VFO-700S (optional).
22. Built-in, switchable receiver pre-amp.

SECTION 2. INSTALLATION

2-1. ACCESSORIES

The Model TS-700SP transceiver is supplied with the following accessories:

Operating manual.....	1
Warranty card.....	1
RCA plug.....	2
Feet with screws.....	2
Fuse: 1A (AC 220V).....	1
2A (AC120V).....	1
2A (DC 20V).....	1
5A (DC cord).....	1
Microphone (with bracket), 500 ohm.....	1
AC power cord with connector.....	1
DC power cord with connector.....	1
VFO plug (installed).....	1
Speaker plug 1/8".....	1
Tone pad plug (4P DIN).....	1

2-2. OPERATING LOCATION

As with all solid-state electronic equipment, the place of use must be selected to avoid extremes of ambient temperature.

A well-ventilated, dry location, where the transceiver will not be exposed to direct sunlight, should be selected. The TS-700SP has a heat sink on its rear panel; be sure to install the transceiver so there is adequate clearance at the rear and bottom. For better heat dissipation, position it away from walls. This precaution also applies when the transceiver is operated mobile.

When you wish to use the transceiver in a car, but sure to provide heat dissipating clearance under and behind, and to make proper provisions against physical shock. A rigid mounting is advisable.

2-3. POWER SUPPLY CONNECTION

The TS-700SP is designed to operated on AC 120/220V or DC 13.8V. Switching between AC and DC is accomplished by replacing the power cord. The DC power cord is color coded (red for "+" and black for "-"). When connecting the power cord, be sure to observe the following:

1. Turn off the power switch and set the standby switch to REC position.
2. When replacing the power cord, disconnect it from the AC supply (or battery). When connecting the AC power cord. Use care to prevent electrical shock. Each power cord is equipped with a 4P plug complete with locking tabs. When installing the plug, squeeze the tabs to ensure their mating with the transceiver. To remove again squeeze the locking tabs to disengage the plug from the transceiver, and withdraw. (See Fig. 1)

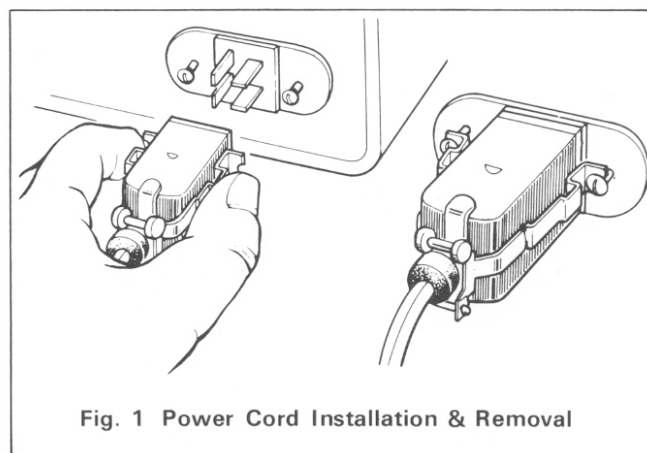

Fig. 1 Power Cord Installation & Removal

2-4. ANTENNA CONNECTION

A good antenna is important. A ground-plane or a Yagi will give best results. The antenna should be 10 to 20 meters high and connected to the antenna terminal of your transceiver through a coaxial cable.

Use a non-directional antenna for local communications, and a directional antenna for DX.

2-5. MICROPHONE

A 500-ohm microphone is supplied with the transceiver. Another microphone may be used providing it matches the transceiver. For connector wiring, refer to Fig. 2 and Fig. 3.

2-6. KEY

For CW operation, connect a key to the KEY jack at the rear of the transceiver.

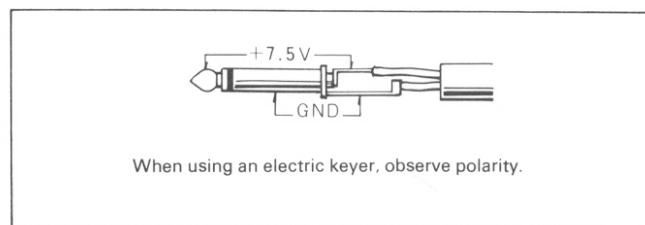

2-7. EXTERNAL SPEAKER

A speaker is included in the transceiver. If you wish to use an external speaker, connect it to the EXT SP jack at the rear of the transceiver by using the supplied 1/8" speaker plug.

A speaker rating of 8 ohms is recommended. Plugging in an external speaker will automatically disconnect the built-in speaker.

When connecting an external speaker, be careful not to short the AF output, and try to minimize cord length.

2-8. MIC HOOK

The microphone bracket furnished with your transceiver may be installed on the left or right side. Per Fig. 4.

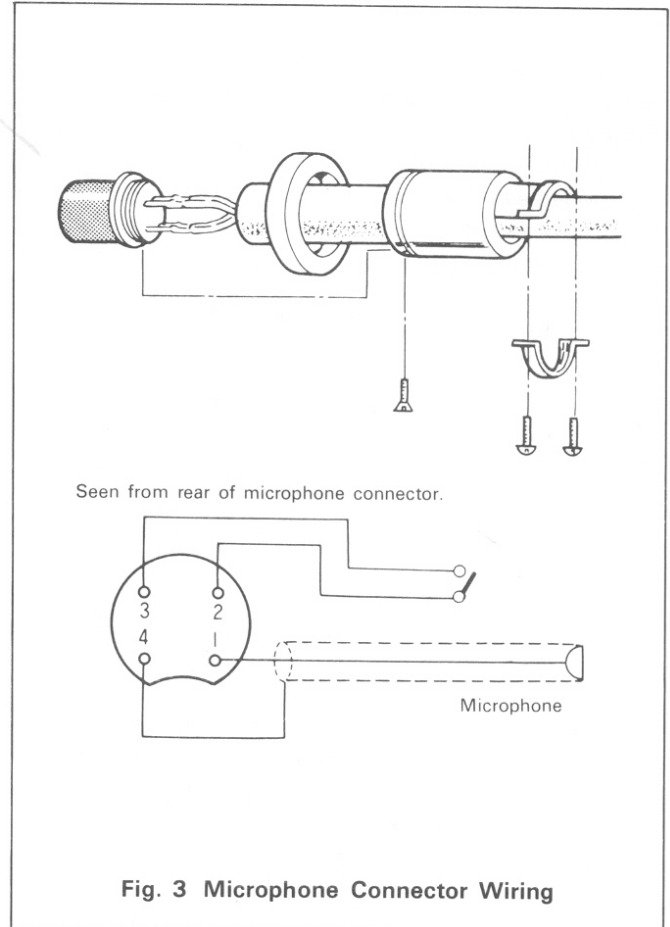
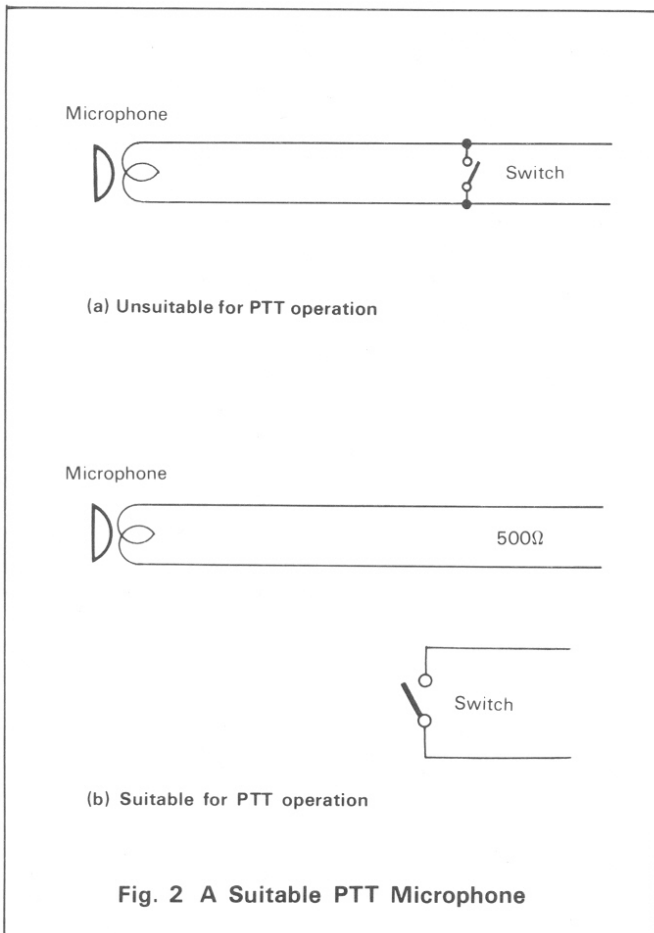
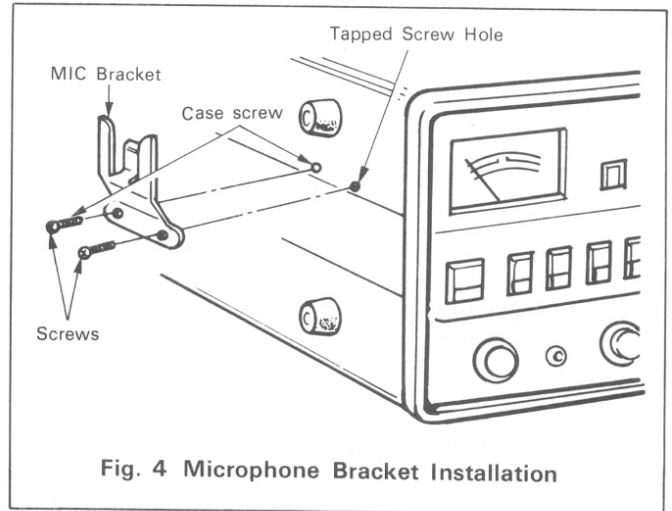

SECTION 3. OPERATING CONTROLS

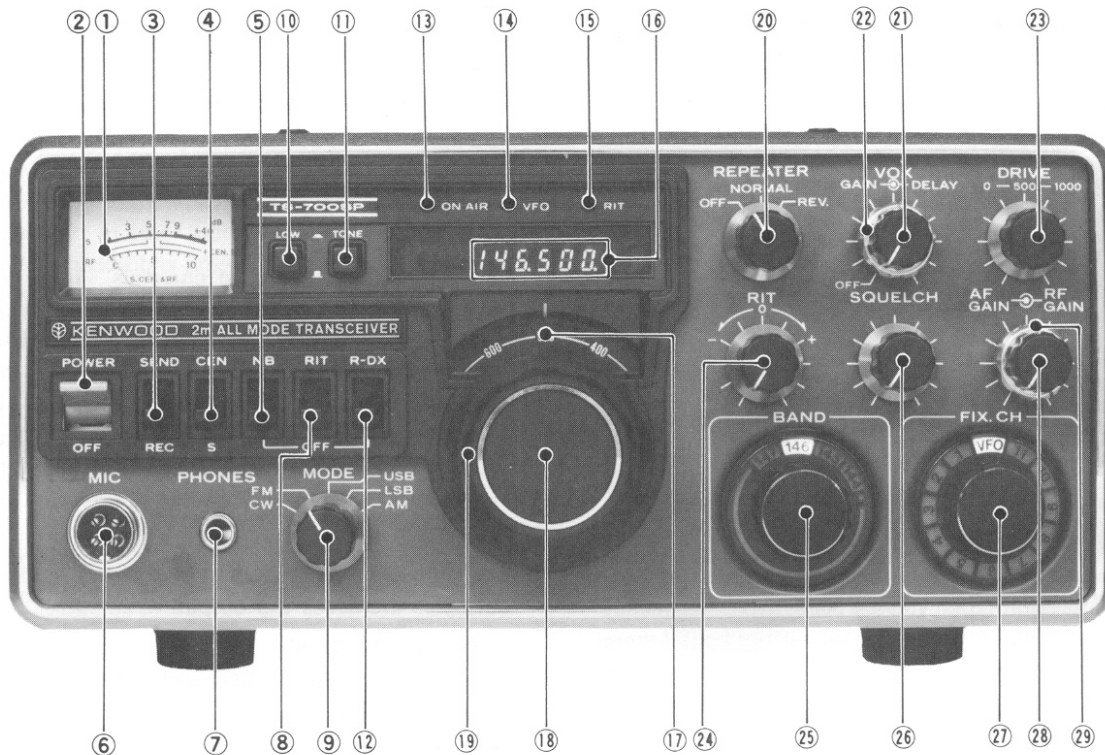

3-1. FRONT PANEL CONTROLS

① METER

This meter has three functions. During reception, it serves as an "S" meter indicating the strength of received signal on a scale graduated from 1 to 9, 9 + 20 dB and 9 + 40 dB. During transmission, the meter indicates RF output. The meter also functions as a center meter during FM reception when the METER switch is set to the CEN position.

② POWER SWITCH

The power to the transceiver is turned on by setting the power switch to the up position, and turned off at the down position.

③ STANDBY SWITCH

The SEND position is for transmission and the REC position for reception. With the switch in the REC position, the transceiver automatically shifts from receive to transmit if the microphone PTT switch is keyed.

④ METER SWITCH

During FM reception, the meter functions as an "S" meter or a center meter. In other receiving modes, the meter functions as an "S" meter regardless of switch position.

⑤ NB (Noise Blanking) SWITCH

Turning on this switch will suppress pulse type (ignition) noise.

⑥ MICROPHONE JACK

For microphone connection. This jack has terminals for both microphone input and the PTT circuit.

⑦ PHONES JACK

For connection of 8 to 16 ohm headphones. The speaker is disconnected when the headphones are plugged in.

⑧ RIT SWITCH

For on-off control of the RIT (Receiver Incremental Tuning) circuit.

⑨ MODE SWITCH

By using this switch, any of the following five modes can be selected:

CW:

Morse-code telegraphic communications (A1)

FM (Frequency Modulation):

Form Voice Communications (F3)

USB (Upper Side Band):

For operation in the 145 MHz band, international practice calls for USB (A3J).

LSB (Lower Side Band):

A3J.

AM (Amplitude Modulation):

A3.

⑩ LOW POWER SWITCH

This switch, when pressed in, reduces the FM transmit power to approximately 1W.

⑪ TONE SWITCH

Turning on this switch in the FM mode will activate the tone burst circuit for repeater operation.

⑫ R-DX SWITCH

This switch controls the receive pre-amp.

⑬ ON AIR INDICATOR

This indicator lights while the transceiver is in transmit mode.

⑭ VFO INDICATOR

This indicator lights while the VFO is in operation.

⑮ RIT INDICATOR

This indicates the RIT circuit is operating.

⑯ DIGITAL DISPLAY

The digital display shows the transmit and receive frequencies for simplex operation. If you are using a fixed frequency position instead of the VFO, the display will not light if there is no crystal in that position. Therefore, the display may be used as an indicator to tell what positions have crystals installed.

⑰ SUB-DIAL

This dial scale is graduated from 0 to 1000 at 100 kHz intervals, covering a width of 1 MHz.

⑱ MAIN TUNING (Inner Vernier)

For setting the transceiver to the desired frequency. Rate of change is 25 kHz per turn.

⑲ COARSE TUNING (Outer)

Rate of change is 100 kHz per turn.

⑳ REPEATER CONTROL

Repeater offset is determined by this control offset is either +600 kHz or -600 kHz as desired. (Refer to 4-16. "Repeater Operation".)

㉑ VOX GAIN/OFF CONTROL

This knob switches the VOX on and controls its gain. To switch off, turn the control fully counterclockwise.

㉒ VOX DELAY CONTROL

This control adjusts the hold time of the VOX circuit.

㉓ DRIVE CONTROL

This controls HET mixer electronic tuning during transmission.

㉔ RIT CONTROL

The RIT allows the operator to vary the receive frequency greater than ± 2 kHz without changing the transmit frequency. At the "0" (mid scale) position, the receive frequency is the same as the transmit frequency. The RIT circuit may be used during VFO or fixed channel operation.

㉕ BAND SWITCH

For selecting the band to be operated. For bands, 1 MHz wide, are provided, from 144 to 147 MHz.

㉖ SQUELCH CONTROL

Turning this control clockwise during FM will set the SQUELCH ON. It is normally adjusted clockwise so internal receiver noise can just be eliminated.

㉗ FIX CH SWITCH

For selecting VFO or fixed channels. There are 11 fixed channels in each band (a total of 44 channels in 4 bands). The frequency fraction of the crystals in these 4 bands remain the same: for instance, the operating frequency of 144.48 MHz in the 144 MHz band changes to 145.48 MHz, 146.48 MHz and 147.48 MHz in the 145 MHz, 146 MHz and 147 MHz bands respectively. The fixed channels can also be used for repeater operation.

㉘ AF GAIN (Inner)

This adjusts the gain of the receiver audio amplifier. Clockwise increases the output.

㉙ RF GAIN (Outer)

For adjusting the RF amplifier gain of the receiver. Turned to the extreme clockwise position, gain is maximized. The "S" meter indicates the gain set by this control.

3-2. INTERNAL CONTROLS

① **SPEAKER TERMINAL**

For connection of the internal speaker.

② **SSB MIC GAIN/7TH DIGIT DISPLAY (FM)**

This is used to adjust the microphone gain in SSB mode. Generally, set to mid position. The knob, when pulled out, turns off the 7th digit (100 Hz order) on the digital display in the FM mode only. In other than the FM mode, the 7th digit will not go off. The knob is preset "in" at the factory so the FM display will be in six digits.

③ **AM CAR LEVEL**

This adjusts the AM transmit carrier level.

④ **FM MIC GAIN**

This adjusts the FM transmit microphone gain.

⑤ **ANTI VOX**

This adjusts the anti-VOX gain during VOX operation.

⑥ **SIDE TONE**

In the CW mode, this adjusts side tone gain.

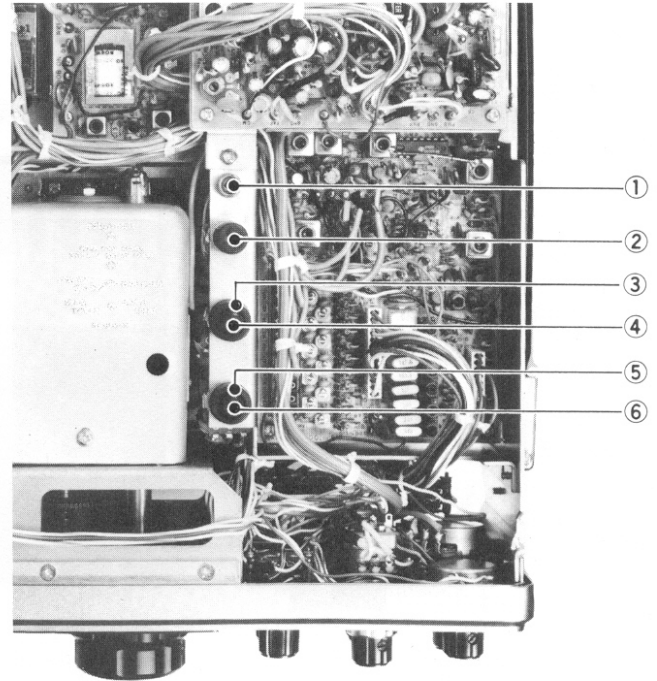

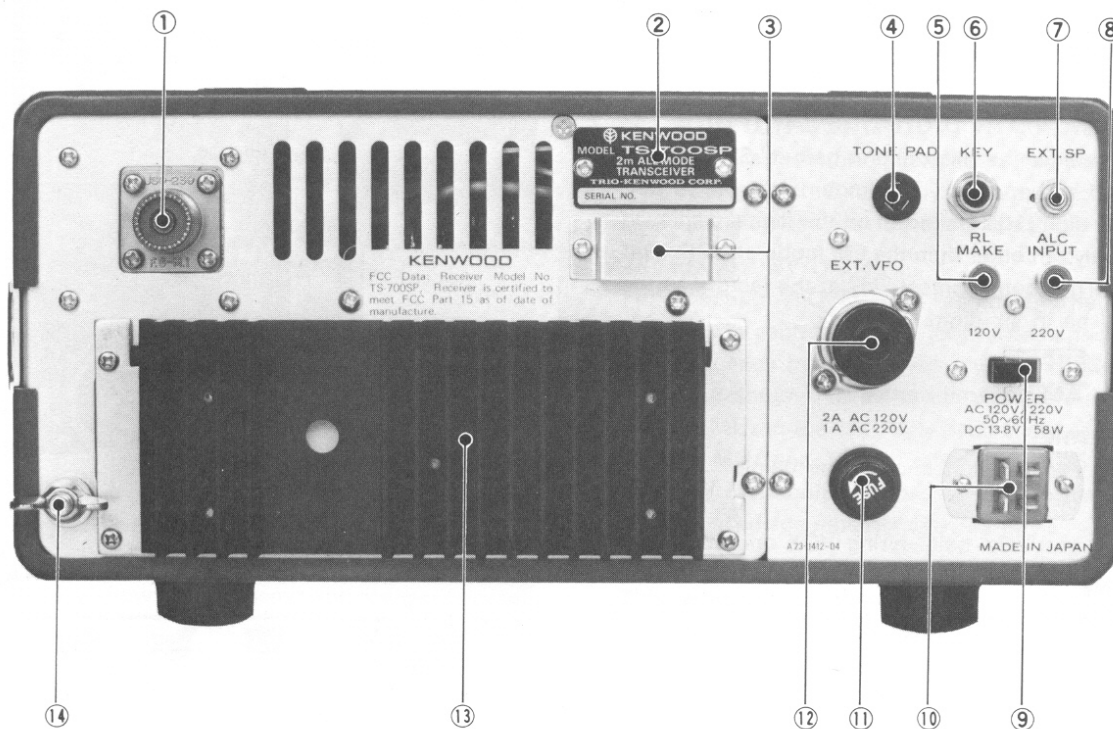

3-3. REAR PANEL CONTROLS

① ANT TERMINAL

For connection of an antenna.

② NAME PLATE

TS-700SP serial number is marked on this plate.

③ TRANSISTOR PROTECTIVE COVER

The transistors in the AVR (Automatic Voltage Regulator) circuit for 11V and 20V lines are protected by this cover. It also functions as a heat sink for these transistors.

④ TONE PAD CONNECTOR

The connection is shown on page 16 Fig. 9 of the tone pad instruction.

⑤ RL-MAKE CONNECTOR

This is a normal opened relay contact. It is grounded in transmit.

⑥ KEY JACK

This jack is used for operating the transceiver in CW mode. Connect an external telegraph key.

⑦ EXT SP TERMINAL

For connection of an external 8Ω speaker.

⑧ ALC-INPUT CONNECTOR

External ALC connector from a linear amplifier.

⑨ AC POWER SELECT SWITCH

Set this switch to your local AC line voltage. When the switch setting is changed, be sure to replace the fuse with one of proper value. (120V = 2A. 220V = 1A).

⑩ POWER CORD JACK

For connection of the supplied AC or DC power cord.

⑪ AC FUSE HOLDER

AC primary power fuse. (120V/2A or 220V/1A.)

⑫ EXT VFO CONNECTOR

For connection of the remote VFO, VFO-700S (optional). When the VFO-700S is not used, be sure to keep the 9-pin MT plug installed. **If not, the TS-700SP will not work, either transmit or receive.**

⑬ HEAT SINK (For Transmitter Final Stage)

Dissipates heat from the RF power amplifiers.

⑭ GROUNDING

To prevent electric shock, TVI and BCI, be sure to wire the TS-700SP to a good earth ground. Use grounding wire as thick and short as possible. Bury a ground rod or plate as deep as possible. Do not use gas pipes for ground!

SECTION 4. OPERATING INSTRUCTIONS

4-1. RECEPTION

After connecting the power cord, antenna, microphone, key etc., set controls following Table 1.

Turn the POWER switch ON. Pilot lamps in the meter, sub-dial pointer, band switch and FIX CH switch will light up, indicating the transceiver is ready for operation. Because of solid-state design, the transceiver can be put into operation immediately after power is applied.

Next, adjust the controls according to Table 2.

Note: The DRIVE knob does not function during reception.

Table 1. Front Panel

POWER Switch	OFF
Standby Switch	REC
METER Switch	S
NB Switch.....	OFF
RIT Switch	OFF
R-DX Switch	OFF
MODE Switch	As desired.
REPEATER Knob	OFF
RIT Knob.....	O
VOX Knob.....	Fully counterclockwise
SQUELCH Knob	Fully counterclockwise
RF GAIN Knob	Fully clockwise
AF GAIN Knob	Fully counterclockwise
BAND Switch.....	Desired band
FIX CH Switch	VFO

The foregoing settings are common to all modes of operation. Each mode, however, calls for special techniques, which will be discussed for each of the five modes.

CW Mode (How to Use the RIT)

With the RIT switch turned off, position the MAIN tuning so the incoming CW signal will beat at 900 Hz. You will then have zeroed your transmit frequency to the incoming CW signal.

(Your transmit frequency perfectly coincides with the transmit frequency of the other party.)

Similarly, if the other party calls back with 900 Hz beat in response to your call of the other party's transceiver is zeroed. Should the other party call back with a beat off 900 Hz, or should you want to receive with a beat of your choice, turn on RIT switch and adjust the RIT knob to obtain the desired beat.

Table 2

Controls	Setting
AF GAIN	Turn clockwise for suitable volume.
MAIN TUNING	Adjust for clear signal.
RF GAIN	Normally, set at the extreme clockwise position. When a signal is very strong, turn counterclockwise for reduced gain.
SQUELCH	This is used for FM operation. Turn the knob clockwise so that receiver noise at no-signal just disappears.
RIT	With the RIT switch ON, turn the knob in either direction to vary the receive frequency. Refer to Page 8 "RIT" operation.

FM Mode

Set MAIN Tuning for optimum reception. By setting the METER switch to the CEN position, the meter functions as a center meter. Turn the MAIN dial until the center meter pointer deflects to the center scale line while receiving the other party's signal. In this way, your transmit frequency will coincide with the receive frequency.

Next, set the METER switch to the "S" position and the meter will indicate the strength of the incoming signal. If, in this case, the meter pointer fluctuates in response to the receiver audio, turn the MAIN dial a little (a few kHz) in either direction until the meter indication is stabilized (if no fading exists).

Since the SSB IF is part of the "S" meter circuit for FM, the "S" meter provides a logarithmic indication of FM signal strength that is free from saturation even when the input signal strength is very high. This eliminates the need for calibration of the "S" meter for each mode of operation.

Since the IF bandwidth is wide in the FM mode, a slight deviation in frequency does not affect reception. When transmitting, however, it is necessary to be exactly on frequency because the other party may be crystal controlled. Therefore, it is advisable that you "zero" the other party by adjusting the MAIN tuning for a "O" indication on the center meter.

If the "S" meter continues to fluctuate or if satisfactory audio output is not obtainable, it is very likely that the other party is sending SSB. You can easily check this by turning the MODE switch to USB or LSB position.

SSB Mode

Traditionally, USB is used on 2m. Operating technique is the same for USB or LSB.

Generally, the "Tuning" technique for SSB reception requires a little experience.

A. Determining Received Signal Mode

(1) By using the MODE switch.

If a clear signal is heard in the FM position of the mode switch, the signal is FM. An SSB signal will not be intelligible in the FM mode.

(2) By using a beat.

In the SSB mode, a beat will be heard if you are not receiving an SSB signal.

B. Dial Setting

When the received signal is found to be SSB, turn the dial to the point where the sound is most clear (this is the "zero" point).

If clear sound cannot be obtained it may be an indication that the signal is LSB. Set the MODE switch to LSB and retune.

- Note:**
1. If the frequency of the other party changes after the "zero" point has been obtained, set the RIT switch ON and adjust the RIT control.
 2. When the RIT feature is used, the receive frequency will be different from the transmit frequency. Therefore, the RIT must be set to "0" or the RIT switch to OFF before you establish another contact.

AM Mode

AM signals cannot be demodulated in the FM mode. They will be heard as a continuous beat in the SSB mode. Optimum reception of an AM signal is obtained by tuning the transceiver for maximum "S" meter indication. The bandwidth of the receiver crystal filter is somewhat narrow for an AM signal because this filter is primarily for SSB reception. The audio output may have some of its high frequency components suppressed and hence lack clarity. This may be remedied by using the RIT control to shift the receive frequency.

Where your transceiver and that of the other party are both TS-700SP, it should be noted that, in AM mode, the transmit carrier frequency is higher than the receive carrier frequency by 600 Hz.

Accordingly, you first "zero" your frequency to that of the other party by adjusting MAIN tuning and then transmit to which the other party will respond after possibly changing his frequency. If he should do so, you re-match your frequency to his frequency by using your RIT. (Refer to Fig. 5)

4-2. TRANSMISSION

Before transmitting, perform all the necessary procedures for optimum reception. Make sure that the frequency you have selected does not interfere with other stations.

Adjust the controls (DRIVE, MIC GAIN etc.) for good quality transmission. Connect a 50 ohm dummy load or antenna to the transceiver before starting to load or the various controls. The use of a dummy load is recommended because this prevents the possibility of causing interference to other stations. Use a dummy load capable of dissipating 20 watts or more of RF power. The tuning procedure should be completed in the least amount of time possible for maximum life of the output transistors. Set the controls as shown in Table 3.

Table 3. Initial Settings of Front Panel Control

Standby Switch	REC
RIT Switch	OFF
MODE Switch	CW
REPEATER Knob	OFF
VOX Knob	Fully counterclockwise
DRIVE Knob	Center position
RIT Knob	0
SQUELCH Knob	Set for optimum effect
AF GAIN Knob	Set for proper volume on reception
RF GAIN Knob	Fully clockwise
BAND Switch	144
FIX CH Switch	VFO
SUB DIAL	500

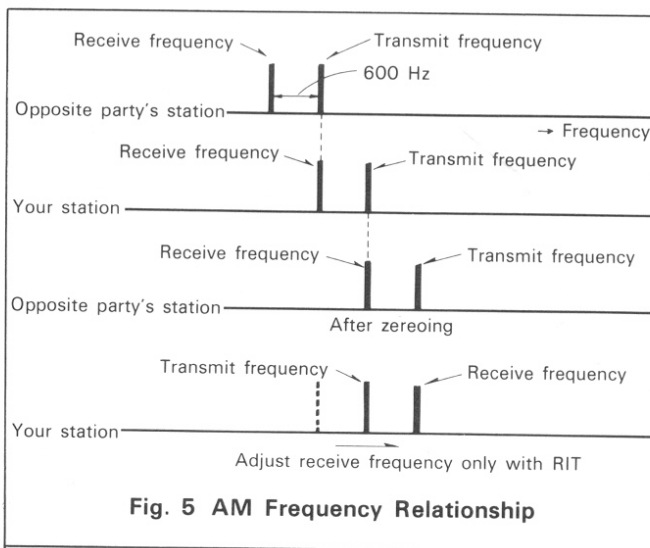

CW Mode (Fig. 6)

Turn the BAND switch to the desired range. Turn the MODE switch to the CW position. Shift the STANDBY switch from REC to SEND and verify the meter pointer deflects and the ON AIR indicator lights, and return to the REC position.

Move the STANDBY switch to the SEND position and adjust the DRIVE control for maximum deflection of the meter pointer.

Note: Since the ALC is turned on during a full power transmission, the drive knob provides wide tuning. Engage the LOW-POWER switch to facilitate this tuning operation.

The foregoing procedure should be carried out rapidly. If a telegraph key has already been connected to the transceiver, during adjustments the device should be set to "key-down". Having adjusted the transceiver as above, you are now ready CW communication.

Adjusting Side Tone

Side tone enables monitoring the CW signal of your station. To adjust the side tone volume, open the top cover and turn the SIDE TONE knob for desired level. This adjustment should be made in receive with the key pressed down as the monitor circuit is activated in receive and transmit.

Other Modes

When the transceiver is properly adjusted for operation in CW mode, it is ready for use in other modes (FM, LSB, USB or AM). Connect the microphone and speak after shifting the STANDBY switch to SEND position. Your voice will now be transmitted.

Microphone gain adjustment for FM and SSB (USB, LSB) can be made by the controls which become accessible when the top lid of the transceiver is opened. Optimum setting is about the mid position of their turning range (see page 9). Microphone gain should be adjusted to assure good quality transmission. In AM mode, optimum output can be obtained by adjusting the AM CAR knob (see page 9) inside the transceiver until the meter indicates anywhere between "3" and "5" in transmit.

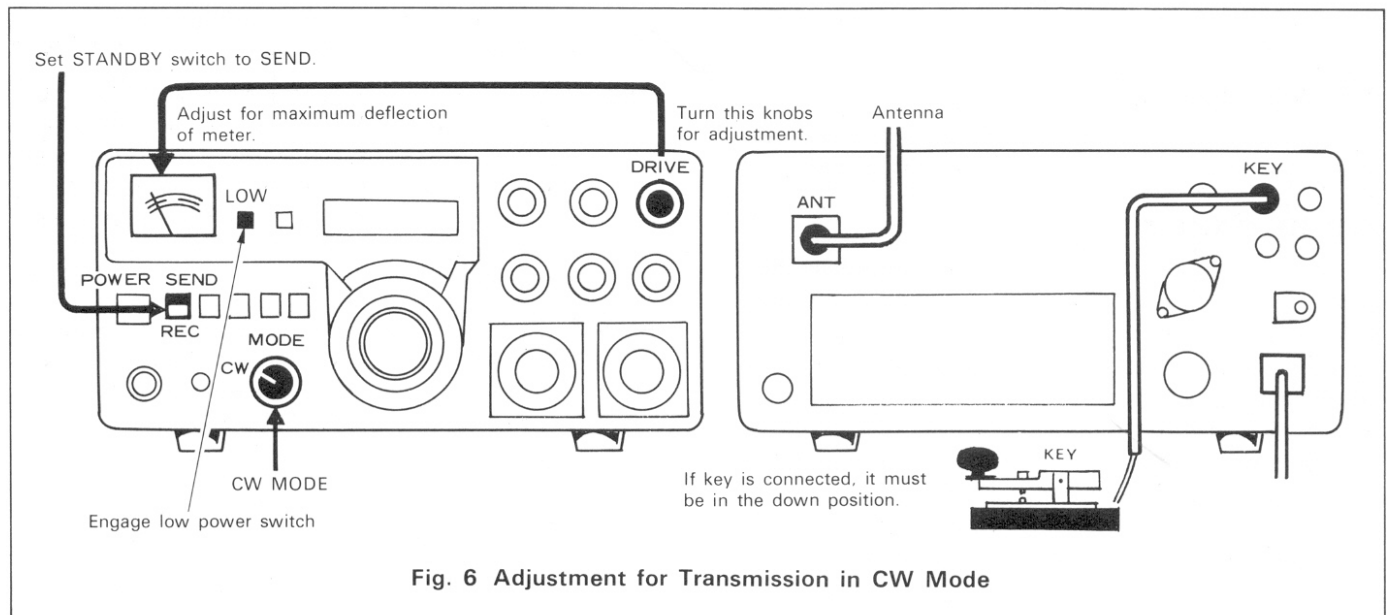

Fig. 6 Adjustment for Transmission in CW Mode

PTT (Push-To-Talk) Operation

By connecting the supplied microphone or any other microphone equipped with a PTT switch (KENWOOD's MC-50, etc.), the transceiver is readily used for PTT operation. For communication, depress the PTT switch with the STANDBY switch left in the REC position.

4-3. R-DX (Receive Pre-Amp)

Under normal conditions, your TS-700SP has enough sensitivity to receive incoming signals of average strength. For weak signals and DX communications, the pre-amp may be used. This is turned on by the R-DX switch. The gain of the receiver RF stage is increased by several dB, thus increasing sensitivity.

When using the pre-amp, the receiver is more susceptible to cross-modulation and blocking from strong signals. It is only effective on weak signals. The booster also amplifies external noise. Sometimes turning on the noise blanker will reduce this noise.

4-4. RIT (Receiver Incremental Tuning)

The term "RIT" is an abbreviation for "receiver incremental tuning". The RIT feature enables you to shift the receive frequency without changing the transmit frequency. The receive frequency may be shifted up to ± 2 kHz.

Note: The digital display does not show this frequency shift.

If you want to talk to two stations that are not exactly on the same frequency, proceed as follows:

1. Tune in one of the stations (RIT off).
2. Turn on the RIT and tune in the other station with the RIT control. The RIT indicator will light.

Remember to turn the RIT off before tuning to another frequency.

4-5. NB (Noise Blanker)

The NB (Noise Blanker) switch is used to suppress pulse noise such as ignition noise generated by cars.

4-6. RF GAIN (Fig. 7)

This is used to adjust the receiver RF stage gain. Normally, leave it fully clockwise. For a very strong incoming signal, turn it counterclockwise. If there is a strong signal in the vicinity of your operating frequency, lower the RF gain to reduce intermodulation interference.

If the RF GAIN is reduced excessively, the "S" meter deflection will increase irrespective of incoming signal strength, and is due to the circuit characteristic.

The RF AGC circuit is the threshold type; the "S" meter will read correct signal strength at all time.

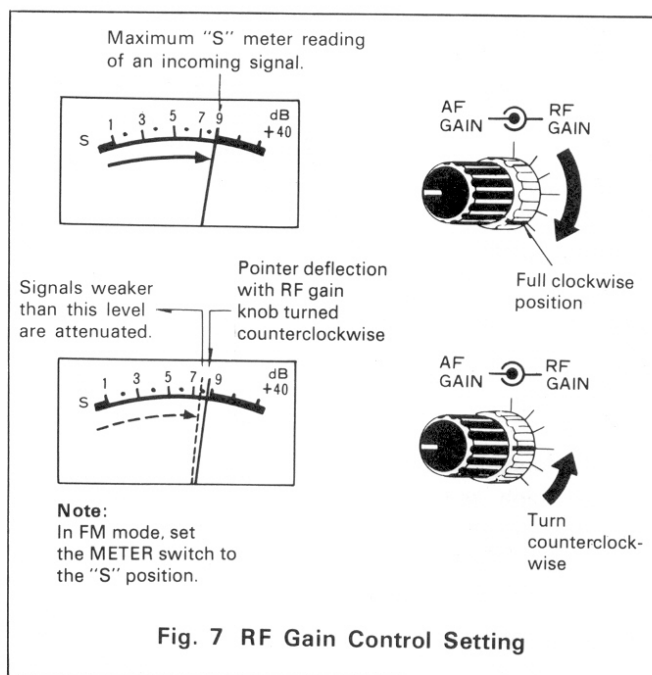

Fig. 7 RF Gain Control Setting

4-7. LOW POWER SETTING

For courtesy, it is recommended that you use low power for local FM communications. This is accomplished with the LOW power switch. Output power is reduced to about 1 watt when it is depressed.

Note: The RF meter reads relative transmit power, but it cannot absolutely indicate power as affected by antenna conditions. However, you can judge transmit power, assuming the RF meter deflects to "8" for rated output under normal operating conditions. It decreases to "1" or "2" with the LOW power switch engaged.

Caution: In the SSB mode, leaving the LOW power switch ON causes low ALC voltage, which could result in distortion. Therefore, do not use the LOW power switch in other than the FM mode.

4-8. READING OPERATING FREQUENCIES

The digital display indicates carrier frequency in all operating modes. The frequency displayed is your exact operating frequency.

Note: In CW mode, the receive frequency includes the beat frequency +900 Hz. It does not indicate RIT offset.

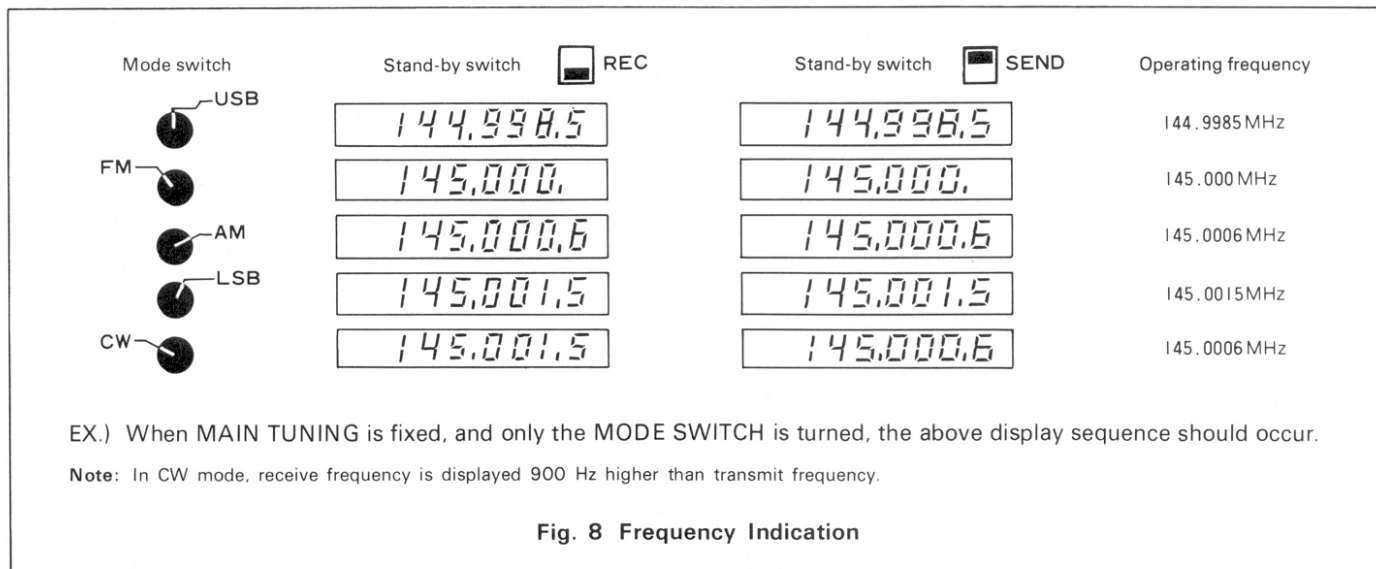

4-9. SUB-DIAL

The sub-dial reads 100 kHz divisions in addition to the digital display. The sub-dial is used to read approximate frequency, while the digital display shows the exact frequency.

4-10. TONE PAD INPUT

The TS-700SP has a tone pad input for "Auto patch" operation. Wire the supplied miniature plug to your tone pad as shown Fig. 9.)

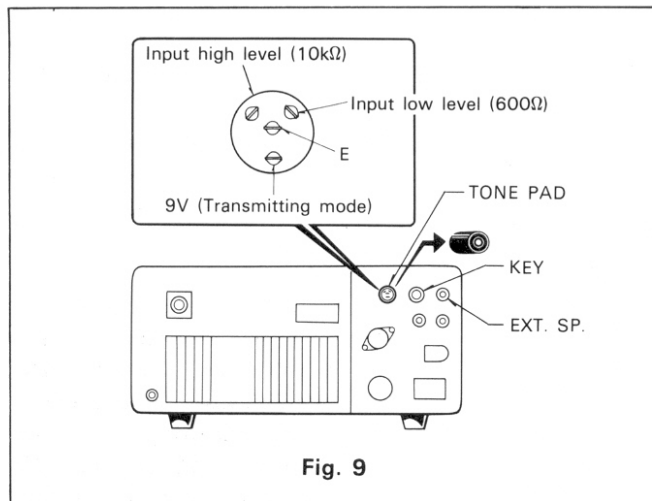

4-11. 7TH DIGIT DISPLAY (FM)

The frequency display indicates to 100 Hz in the SSB, CW and AM modes. In the FM mode, it normally indicates to 1 kHz. The display may be extended to 100 Hz by the 7th DIGIT DISPLAY switch (pull on).

Example: Frequency display with switch pressed in (OFF):

144.320.0 ← 7digit display for other than FM mode.
 144.320 ← 6-digit display for FM mode.

4-12. VOX OPERATION

The VOX (Voice Operated Transmit) automatically keys the transmitter when you speak into the microphone with the VOX switch ON, in the REC position. The TS-700SP will return to the receive state when you stop talking.

CONTROL SET-UP

(1) Adjusting VOX GAIN

First, turn the VOX GAIN control clockwise to switch it on, leaving the STANDBY switch at REC. Further, adjust the control clockwise until the TS-700SP keys to transmit when you speak into the microphone at normal volume.

However, excessive VOX gain results in misoperation by ambient noise. Note that the ON AIR indicator lights in the transmit state and goes off in the receive state.

(2) Adjusting the ANTI VOX

This control, located inside the cabinet (see page 9), is used to prevent speaker sound from misoperating the VOX. Set up the VOX GAIN as directed in Item (1), above. Adjust the AF GAIN for typical speaker volume while receiving a signal of moderate strength. Bring the microphone near the speaker (20 to 30 cm), and adjust the ANTI VOX until speaker sound will not activate the VOX. However, excessive ANTI VOX will inhibit transmit switching.

(3) Adjusting VOX DELAY

This control is used to hold the transmitter on after VOX activation. If the hold time is too short, the TS-700SP returns to receive whenever you pause. If too long, the transceiver will not return to receive after speaking. Adjust for speaking at your normal speed.

This control also sets hold time during CW semi-break-in.

Caution: If the VOX is left "on", the TS-700SP will momentarily transmit when the POWER switch is turned "on". After VOX operation turn the VOX OFF.

4-13. SEMI-BREAK-IN OPERATION

Your TS-700SP is capable of CW semi-break-in operation, in addition to the usual break-in with the STANDBY switch. Semi-break-in uses the side tone to activate the VOX, which switches to transmit when the key down. For VOX operation, turn the VOX ON and set the MODE switch to CW.

4-14. FIXED CHANNEL OPERATION

The TS-700SP has a built-in crystal oscillator circuit for fixed channel operation. This can be used when the transceiver is frequently operated on specific frequencies. Examples are: FM operation on a repeater, mobile SSB operation, and net operation.

The FIX CH knob has a total of 11 fixed channel positions.

The crystal frequency for a fixed channel can be computed from the following formula:

Crystal Oscillator Frequency for FM, AM and CW

$$\text{Crystal oscillator frequency (MHz)} = X - (125.10 + 10.70)$$

X = Desired operating frequency (MHz)

125.10 (MHz) = Heterodyne frequency for 144 MHz band

10.70 (MHz) = Transmitter IF frequency

The TS-700SP employs a MIX, or synthesis system. If crystals are cut for the 144 MHz band, they will also operate at 145 MHz, 146 MHz and 147 MHz by switching

the BAND switch. The three frequency decimal places remain the same for each band.

Example: When crystals are cut for 144.480 MHz, the frequencies obtained for each band are as follows:

144 MHz band

$$144.48 - (125.10 + 10.70) = \underline{8.680 \text{ MHz}} \text{ (crystal oscillator frequency)}$$

145 MHz band

$$8.68 + (126.10 + 10.70) = \underline{145.480 \text{ MHz}}$$

126.10 MHz = HET (Heterodyne) frequency for 145 MHz band

146 MHz band

$$8.68 + (127.10 + 10.70) = \underline{146.480 \text{ MHz}}$$

127.10 MHz = HET frequency for 146 MHz band

147 MHz band

$$8.68 + (128.10 + 10.70) = \underline{147.480 \text{ MHz}}$$

128.10 MHz = HET frequency for 147 MHz band

Note: The transmitter carrier oscillator uses an IF frequency of 10.7006 MHz in CW or AM mode. For practical purposes, the 600 Hz offset may be corrected by the RIT control. Although the corrected frequency will not be displayed on the digital.

Crystal Oscillator Frequency for SSB

In SSB mode, your operating frequency will be ± 1.5 kHz from the center frequency of a crystal computed for FM operation.

If you use USB (which is dictated by international amateur practice in the 144 MHz band), select a crystal whose frequency is 1.5 kHz above that of FM. For LSB, the crystal frequency must be 1.5 kHz below that of FM.

When crystals are cut for 144.050 MHz USB, the crystal oscillator frequency is as follows:

$$144.050 - (125.100 + 10.700) + 0.0015 = \underline{8.2515 \text{ MHz}}$$

(0.0015 = 1.5 kHz.)

Note: When the crystal oscillator frequency is 9.200 MHz, the operating frequencies at 144, 145 and 146 MHz bands are 145.000, 146.000 and 147.000 MHz respectively and, therefore, cause no problems. However, if the same crystal were used for 147 MHz band, the operating frequency would be 148.000 MHz; care should be used not to transmit with at this

(148 MHz) frequency. Similarly, if the oscillator frequency is 8.200 MHz the operating frequency is 144.00 MHz in the 144 MHz band; do not transmit at this (144 MHz) frequency.

4-15. MOBILE OPERATION (DC Power)

The TS-700SP also operates from an external 13.8V DC source for mobile operation. Operating techniques are the same for fixed or mobile operation.

Mobile Antenna

There are many types of mobile antenna for 2 meter use. A 1/4 wavelength whip or ground-plane or a 5/8 wavelength antenna is preferred.

Power

The TS-700SP draws about 4 amperes when working full power. This is easily supplied by any automobile battery. When power is supplied from a battery, it is recommended that the automobile engine be run in order to prevent battery discharge. See Section 2.3 for power source information.

Note: For safe driving, it is recommended the transceiver be operated on fixed channels.

4-16. REPEATER OPERATION

Operating Frequency

The 3-position REPEATER control functions as follows:

* OFF Position (Simplex)

Both the transmit and receive frequencies are as indicated on the dial.

* NORMAL Position

The dial frequency indicates the receive frequency. The transmit frequency is 600 kHz below (145, 146 MHz band) or above (147 MHz band) the receive frequency.

* REV Position

The dial frequency indicates the transmit frequency. The receive frequency is 600 kHz below (145, 146 MHz band) or above (147 MHz band) the transmit frequency.

In most cases, repeater operation is effected at the NORMAL position of the REPEATER control. For a repeater system whose transmit-receive frequency relationship is reversed, repeater operation can be achieved by setting the REPEATER control to the REV position.

Note: For 145 MHz repeater operation, an appropriate crystal need be installed; otherwise, transmission and reception cannot be effected at the NORMAL and REV positions of the repeater switch.

For installing the 145 MHz repeater crystal, refer to the instructions on page 23.

The REPEATER control has no effect on 144 MHz band, where the transmit and receive frequencies are always as indicated on the frequency dial. The frequency relationship for each band is given in Table 4.

The digital frequency readout displays the frequencies shown in Table 4 when the REPEATER is used. For example, the readout shows 146.000.0 for both reception and transmission in the 146 MHz band with NORMAL mode and the VFO set to "0". Note that the transmitting frequency is actually 145.4 MHz though the receiving frequency is identical with the display. When switched to the REV position, the readout shows the transmitting frequency.

Table 4

Dial Frequency	Band	REPEATER Band Knob						Repeater Frequency Range (Sub-Dial)
		OFF		NORMAL		REV		
0	144	TX	144.0	RX	144.0	TX	144.0 *1 110~490 *2 600~1000 *3 0~400
		RX	↑	RX	↑	RX	↑	
	145	TX	145.0	TX	144.4	TX	145.0	
		RX	↑	RX	145.0	RX	144.4	
	146	TX	146.0	TX	145.4	TX	146.0	
		RX	↑	RX	146.0	RX	145.4	
	147	TX	147.0	TX	147.6	TX	147.0	
		RX"	↑	RX	147.0	RX	147.6	

- *1. If the MAIN dial frequency is below 110 kHz or above 490 kHz, 145 MHz repeater operation is not recommended.
- *2. If the MAIN dial frequency is less than 600 kHz, the frequency at "600 kHz shift" becomes less than 146.0 MHz which is not recommended for repeater operation.
- *3. If the MAIN dial frequency is higher than 400 kHz, the frequency at "600 kHz shift" becomes more than 148.0 MHz. This means out of band operation if the transmitter is operated at the NORMAL position of the REPEATER control.

The relationship between the sub-dial and the transmit/receive frequencies is shown in Fig. 10.

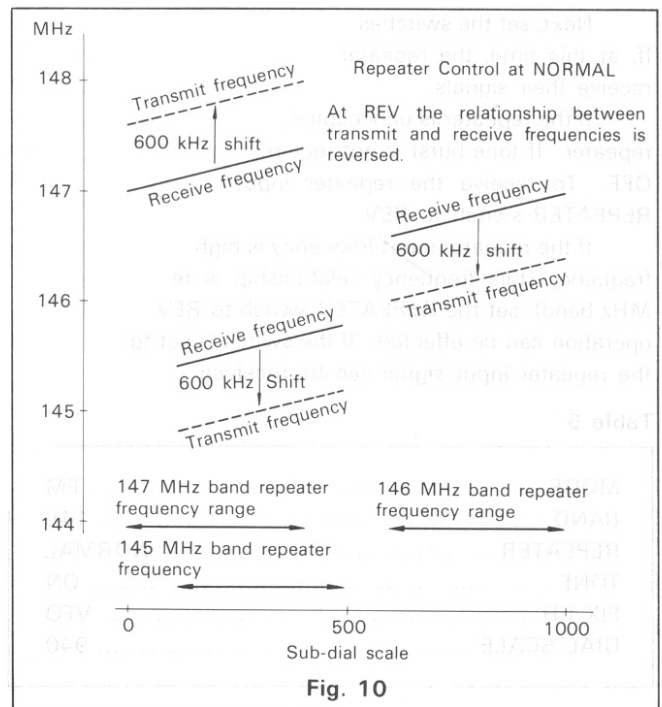

Fig. 10

Repeater Operation

The TS-700SP is designed to operate with repeater systems of the following specification:

Frequency shift: ± 600 kHz

Starting system: Carrier controlled type and tone burst type (oscillator element is optional.)

When the TONE switch is turned ON and the transceiver is keyed in FM by the STANDBY switch or microphone PTT switch, a tone burst signal is emitted for a period of 0.5 to 1.0 second to bring up the repeater.

TONE Burst is easily installed by simply plugging in the tone oscillator element (optional) into the FM IF unit (X48-1120-20) socket.

Example: If your repeater uses an input frequency of 146.34 MHz (FM) an output frequency of 146.94 MHz (FM) and an 1800 Hz tone burst start, first insert an 1800 Hz tone oscillator element into the FM IF unit at the underside of the chassis (see Fig. 11).

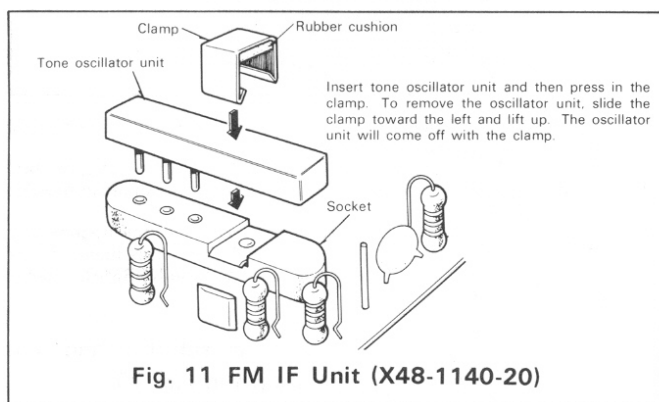

Fig. 11 FM IF Unit (X48-1140-20)

Next, set the switches and knobs as shown in Table 5. If, at this time, the repeater is already occupied, you will receive their signals.

If the repeater is unoccupied, you can transmit into the repeater. If tone burst is not required, set the TONE switch OFF. To receive the repeater input frequency, set the REPEATER switch to REV.

If the repeater input frequency is higher than its output frequency (this frequency relationship is reversed in 147 MHz band), set the REPEATER switch to REV and repeater operation can be effected. If the switch is set to NORMAL, the repeater input signal can be received.

Table 5

MODE.....	FM
BAND.....	146
REPEATER.....	NORMAL
TONE.....	ON
FIX CH.....	VFO
DIAL SCALE.....	940

4-17. OSCAR (Satellite) OPERATION

At present, two amateur radio communication satellites (No. 6 and No. 7) are travelling along the orbit of the earth. These satellites can be used as your repeater. In satellite repeater operation, your TS-700SP will function as the transmitter for the 2m \rightarrow 10m "up-link", or as a receiver for the 70 cm \rightarrow 2m "down-link". Link frequencies in this operation are given in Table 6.

An example of 2m \rightarrow 10m satellite operation using the TS-700SP and an R-599 receiver is shown in Fig. 12. Beside operation as shown OSCAR satellites also provide other applications such as orbit tracking, beacons, etc. Though you need special knowledge on operation, antenna installation etc. With basic knowledge, you will be able to enjoy repeater communication through the amateur satellites with little difficulty.

Note: Full information may be obtained from ARRL Publications, GETTING TO KNOW OSCAR FROM THE GROUND UP and, SPECIALIZED COMMUNICATION TECHNIQUES FOR THE RADIO AMATEUR.

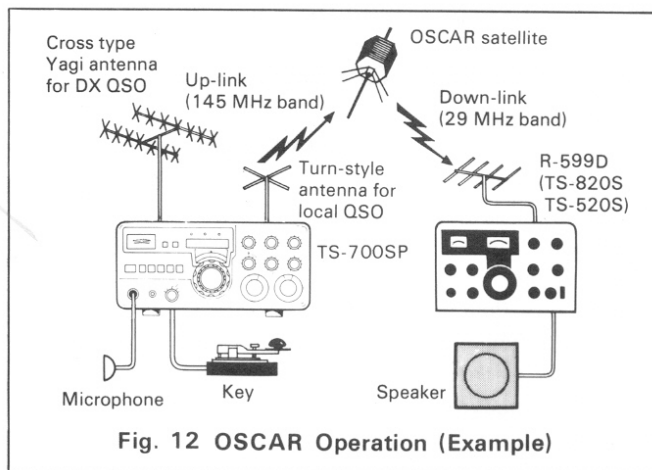

Fig. 12 OSCAR Operation (Example)

(Use Oscar 7, since Oscar 6's battery is almost dead.)

Table 6 Satellite Link Frequencies

REPEATER		
OSCAR NO. 6	OSCAR NO. 7	
2 m \rightarrow 10 m	70 cm \rightarrow 2 m	2 m \rightarrow 10 m
145.900 ~ 146.000 MHz ⇕	432.125 ~ 432.175 MHz ⇕	145.85 ~ 145.95 MHz ⇕
29.450 ~ 29.550 MHz	145.975 ~ 145.925 MHz	29.40 ~ 29.50 MHz
BEACON		
435.100 MHz (300 mW) 29.450 MHz (200 mW)	29.502 MHz (200 mW) 145.975 MHz (200 mW) 435.10 MHz (300 ~ 400 mW)	

SECTION 5. BLOCK DIAGRAM

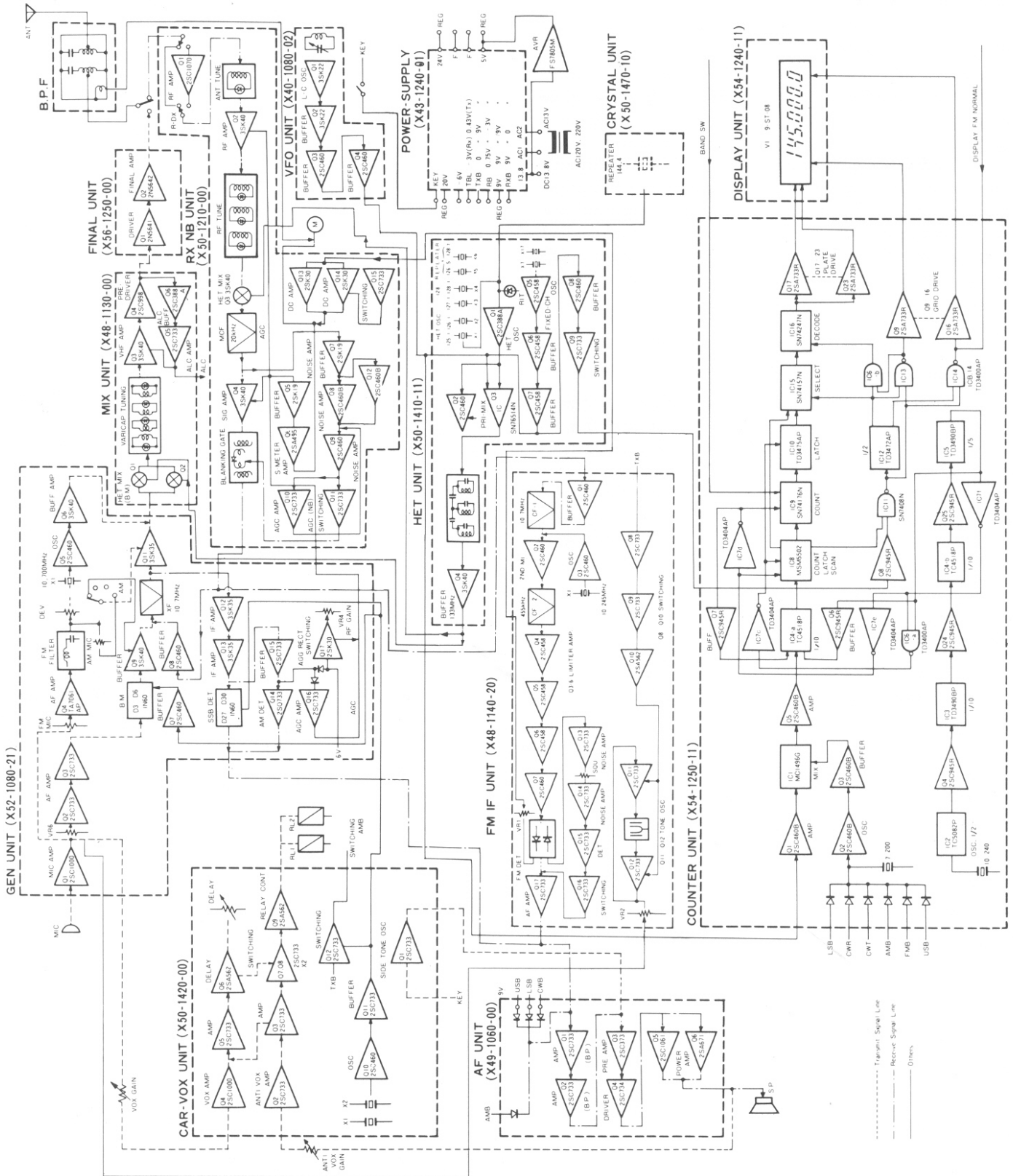

Fig. 13

5-1. BLOCK DIAGRAM

The block diagram of the TS-700SP is shown in Fig. 13. Solid-state components used in this model are: 108 transistors, 19 FET's, 20 IC's and 171 diodes. Circuits are divided into individual units according to operating systems and all units, with the exception of the band pass filters (BPF), are wired and built on printed-circuit boards.

The receiver section operates as a single conversion superheterodyne receiver in SSB mode and a double conversion superheterodyne receiver in FM mode. The transmitter section is single conversion and operates as a filter type unit in SSB mode, a variable reactance frequency shift unit in FM mode, a low power modulation system in AM, and in block bias keying in the CW mode.

Crystal Oscillator Frequencies

CARRIER unit	USB	10.6985 MHz
	LSB	10.7015 MHz
	AM, CW	10.7006 MHz
Generator unit	FM	10.700 MHz
HET unit	144	125.100 MHz
	145	126.100 MHz
	146	127.100 MHz
	147	128.100 MHz

Table 7

Marking	Description
GND	Ground
TXX.....	Transmitter section
RXX.....	Receiver section
VRX.....	Variable resistor
IN	Input
OUT.....	Output
RL.....	Relay
SX	Switch
PLX.....	Pilot lamp

SECTION 6. ACCESSORIES

6-1. ACCESSORIES

For more enjoyable operation of your TS-700SP the following accessories are available from your dealer as options:

Communication Microphone MC-50

A uni-directional dynamic microphone exclusively designed for amateur radio equipment. Provided with a PTT switch and lock output impedance is switchable between 50 k Ω and 600 Ω , and should be set to the low-Z (600 Ω) position.

HS-4 Headphones

The HS-4 headphone set adds versatility to any Kenwood station. For extended periods of wear, the HS-4 is comfortable padded and is completely adjustable. The frequency response of the HS-4 is tailored specifically for amateur communication use. (300 to 3000 Hz, 8 ohms).

MC-30S Noise Cancelling Hand Microphone

Ideal for mobile operation, or for noisy base operation. Noise cancelling is switch selectable. Low-Z, prewired with 4P plug.

Tone Oscillator Unit

Frequency: 1800 Hz
1950 Hz
2000 Hz
2100 Hz
2200 Hz
2250 Hz
2400 Hz
2550 Hz

145 MHz band repeater crystal

Frequency: 125.5 MHz (When FCC approved)

REMOTE VFO — VFO-700S

This is a highly stable, solid-state VFO matches the TS-700SP. With the VFO-700S, you can enjoy advanced communication techniques (Split frequency operation).

EXTERNAL SPEAKER — SP-70

This external speaker is designed specifically to match your TS-700SP, both in looks, and audio output shaping.

6-2. TO CONNECT THE VFO-700S

The remote VFO-700S was developed to further enhance the capabilities of your TS-700SP. To connect the VFO-700S, proceed as follows:

First, remove the 9-pin MT plug located at the rear of the TS-700SP. Connect the supplied VFO and grounding cables as shown in Fig. 14.

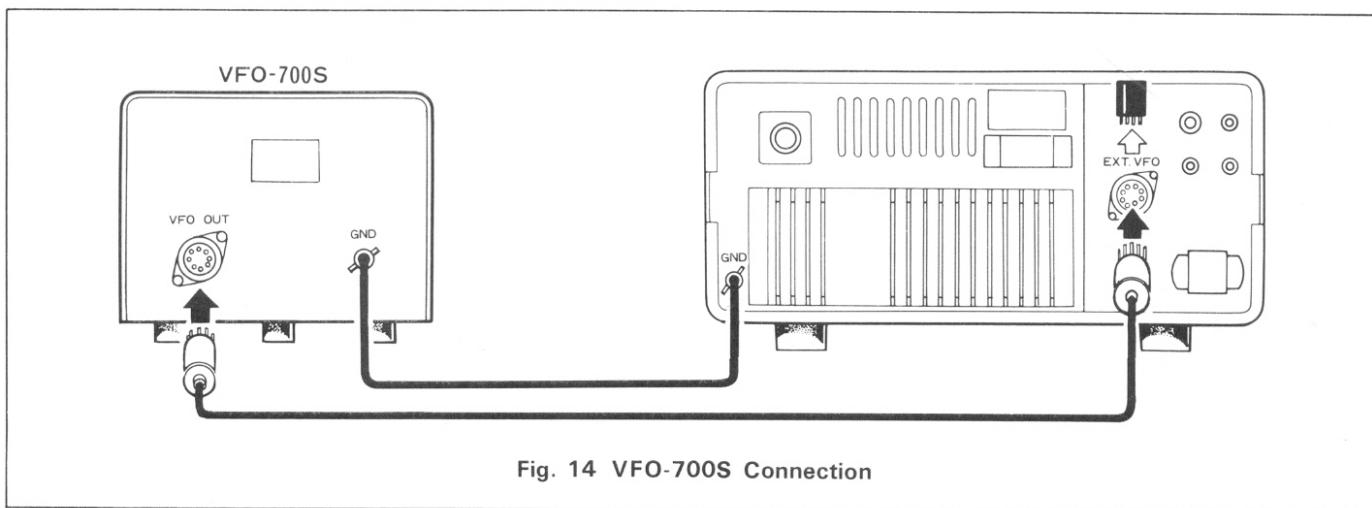

Fig. 14 VFO-700S Connection

SECTION 7. ALIGNMENT

7-1. GENERAL INFORMATION

Your TS-700SP has been factory aligned and tested to specifications before shipment. Under normal circumstances the transceiver will operate in accordance with these operating instructions when properly adjusted. Attempting service or alignment without factory authorization can void the transceiver's warranty.

XTAL Frequency Adjustment

When fixed channel crystals are installed in the transceiver, adjust their frequencies as outlined below. (the relationship between the markings on the FIX CH knob and the crystal oscillator sockets are shown in Fig. 16):

1. Pull up the two latches and open the top lid. (see Fig. 15.)
2. Adjust the trimmers (TC1 ~ TC11) corresponding to the newly installed crystals to produce the desired oscillator frequencies (refer to Paragraph 4-14. "Fixed Channel Operation").

Table 8

f_o (MHz)	Crystal oscillator frequency for FM, AM, and CW.
f_{USB} (MHz)	Crystal oscillator frequency for USB.
f_{LSB} (MHz)	Crystal oscillator frequency for LSB.
X (MHz)	Desired operating frequency

- BAND 1:
 $f_o = X - (125.10 + 10.70)$ (MHz)
- BAND 2:
 $f_o = X - (126.10 + 10.70)$ (MHz)
- BAND 3:
 $f_o = X - (127.10 + 10.70)$ (MHz)
- BAND 4:
 $f_o = X - (128.10 + 10.70)$ (MHz)

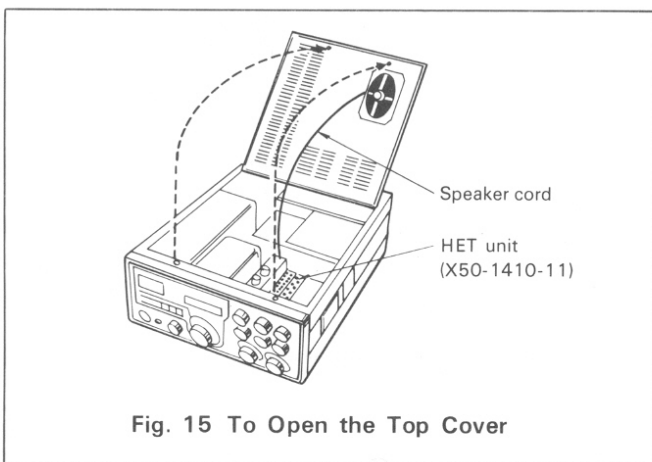

Fig. 15 To Open the Top Cover

- BAND 3:
 $f_o = X - (126.50 + 10.70)$ (MHz)
- BAND 4:
 $f_o = X - (128.70 + 10.70)$ (MHz)
- BAND 1:
 $f_{USB} = X - (125.100 + 10.7000 - 0.0015)$ (MHz)
- BAND 2:
 $f_{USB} = X - (126.100 + 10.7000 - 0.0015)$ (MHz)
- BAND 3:
 $f_{USB} = X - (127.100 + 10.7000 - 0.0015)$ (MHz)
- BAND 4:
 $f_{USB} = X - (128.100 + 10.7000 - 0.0015)$ (MHz)
- BAND 1:
 $f_{LSB} = X - (125.100 + 10.7000 + 0.0015)$ (MHz)
- BAND 2:
 $f_{LSB} = X - (126.100 + 10.7000 + 0.0015)$ (MHz)
- BAND 3:
 $f_{LSB} = X - (127.100 + 10.7000 + 0.0015)$ (MHz)
- BAND 4:
 $f_{LSB} = X - (128.100 + 10.7000 + 0.0015)$ (MHz)

- * Crystal specifications:
 - Type: HC-25/U
 - Oscillation: Fundamental
 - Frequency: 8.200 ~ 9.200 MHz
 - XTAL loading: 32 pf (parallel capacity)/25Ω or less (effective resistance)
- * Electrical characteristics:
 - * Operating temperature: -20°C ~ +60°C
 - * Allowable frequency deviation: Within $\pm 3 \times 10^5$ (25°C)
 - * Frequency vs. temperature characteristic: Within $\pm 3 \times 10^5$ (0 ~ 50°C)

Note: DATA is nominal, and final product may vary slightly from different manufacturers. A full service manual is available as a separate publication.

XTAL Frequency Calibration

1. Connect the power cord to a wall outlet.
2. Turn the POWER switch "on", keeping the STANDBY switch at REC.
3. Pull on the 7-DIGIT (FM) DISPLAY switch inside the TS-700SP

Note: After calibration, press the switch in.

4. Set the FIX. CH switch to the channel to be calibrated.
5. Set the MODE switch to the mode for which the XTAL was cut.
6. While observing the digital display, adjust the trimmer corresponding to the installed crystal, until the digital display reads the specified frequency (see Fig. 16).

Note: Use an insulated tuning tool: Trimmers are not at ground potential.

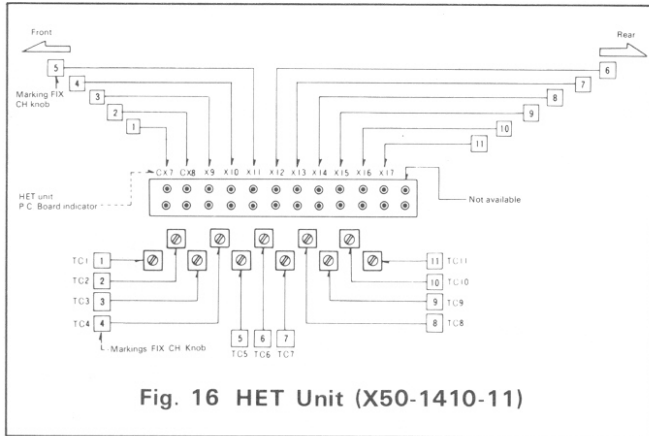

Fig. 16 HET Unit (X50-1410-11)

Installing the 145 MHz Band Repeater Crystal and Frequency Adjustment

Remove the top case (4 screws) and insert the crystal in the crystal unit (X50-1470-10).

Frequency Adjustment:

1. Connect the AC cord and turn on the power switch. Set the standby switch to the REC position.
2. Set the BAND switch to 145 and the REPEATER switch to REV. Set the RIT switch to OFF.
3. Connect a shorting cord (with clips) between the 9V terminal of the HET unit (X50-1410-11) and TP-3 (choke coil lead). Then connect a frequency counter between TP-1 and ground, as shown in Fig. 17.
4. Adjust the crystal unit coil for a counter indication of 125.500.0 MHz.

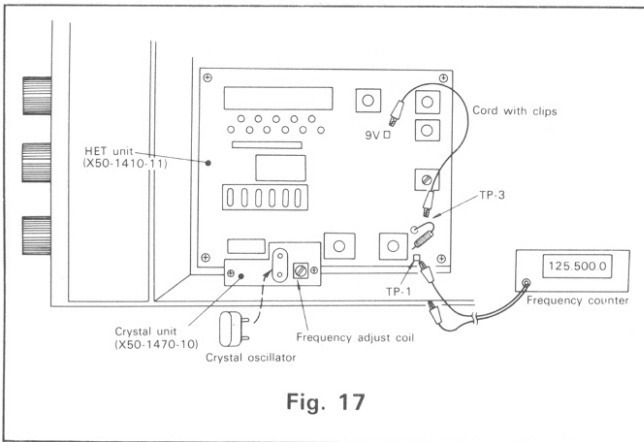

Fig. 17

7-2. ORDERING SPARE PARTS

When ordering replacement or spare parts for your equipment, be sure to specify the following information:

Model number and serial number of the equipment —
Schematic number of the part — and the board number on which the part is located.

Should it ever be necessary to return the equipment for repair, pack in its original boxes and packing, and include a full description of the problems involved.

SECTION 8. TROUBLESHOOTING

The symptoms listed below are in no way indications that the transceiver is defective. If trouble with the transceiver cannot be cleared after the checks have been performed, consult your dealer or your nearest service station.

SYMPTOM	POSSIBLE CAUSE	REMEDY
* Turning POWER switch on will not light pilot lamps.	<ol style="list-style-type: none"> 1. AC power cord is not fully inserted into the connector. 2. Improper power cord connection. 3. Fuse is blown. 	<ol style="list-style-type: none"> 1. Firmly seat the plug into the connector. 2. Reconnect. 3. Replace the fuse (if new fuse blows, the transceiver needs repair).
* Antenna is properly installed but the transceiver will not receive.	<ol style="list-style-type: none"> 1. PTT switch is in "talk" position. 2. FIX CH switch is set to an empty channel. 	<ol style="list-style-type: none"> 1. Turn PTT switch to "receive" position. 2. Rotate the switch to VFO or to an occupied channel.
* No receiver noise from the speaker in FM mode.	<ol style="list-style-type: none"> 1. Squelch circuit is ON. 	<ol style="list-style-type: none"> 1. Turn SQUELCH knob counterclockwise.
* Transceiver is connected to antenna, but no signal is received, while "S" meter pointer remains deflected.	<ol style="list-style-type: none"> 1. RF GAIN control is set too low. 	<ol style="list-style-type: none"> 1. Turn RF GAIN control fully clockwise.
* Even in the absence of signal, "S" meter pointer remains deflected.	<ol style="list-style-type: none"> 1. RF GAIN control is set too low. 2. METER switch is set to CENTER position in FM mode. 	<ol style="list-style-type: none"> 1. Turn RF GAIN control fully clockwise (if meter indication remains the same, the transceiver is defective). 2. Set METER switch to "S" position.
* SSB signal is being received but speaker output remains unintelligible.	<ol style="list-style-type: none"> 1. Transceiver is set for opposite sideband. 	<ol style="list-style-type: none"> 1. Shift MODE switch to opposite sideband.
* RIT control inoperative.	<ol style="list-style-type: none"> 1. RIT switch is OFF. 	<ol style="list-style-type: none"> 1. Set the switch to ON position.
* There is a frequency shift between transmission and reception.	<ol style="list-style-type: none"> 1. RIT control is not in the "0" position while RIT switch is ON. 	<ol style="list-style-type: none"> 1. Set RIT switch to OFF, or set RIT knob to "0" position.
* Noise blanker circuit is not fully effective in suppressing noise.	<ol style="list-style-type: none"> 1. Strong signal exists close to the operating frequency. 2. Some interfering noise similar to a SSB signal in waveform is coming from a nearby source (such as a high-frequency welder or corona discharging device). 	
* No RF power, no display.	<ol style="list-style-type: none"> 1. Absence of 9-pin MT plug in rear panel VFO socket 	<ol style="list-style-type: none"> 1. Firmly seat the MT plug.
* Digital display will not illuminate.	<ol style="list-style-type: none"> 1. EXT VFO connector has no 9-pin MT plug. 2. FIX CH switch is positioned at a vacant channel. 	<ol style="list-style-type: none"> 1. Install 9-pin MT plug in EXT VFO connector. 2. Set FIX CH switch to VFO position.

SYMPTOM	POSSIBLE CAUSE	REMEDY
* VOX will not work.	<ol style="list-style-type: none"> 1. VOX GAIN knob is OFF. 2. VOX GAIN knob is at minimum. (counterclockwise). 	<ol style="list-style-type: none"> 1. Turn VOX GAIN control clockwise to energize. 2. Turn VOX GAIN control clockwise for proper action.
* VOX works, but is activated by speaker sound.	<ol style="list-style-type: none"> 1. Improper ANTI VOX setting. 	<ol style="list-style-type: none"> 1. Turn ANTI VOX control (inside cabinet) clockwise for proper action.
* Turning VFO will not change digital display frequency.	<ol style="list-style-type: none"> 1. FIX CH switch is at fixed channel position. 	<ol style="list-style-type: none"> 1. Set FIX CH switch to VFO.
* No or little AM output.	<ol style="list-style-type: none"> 1. AM carrier control is in minimum position. 	<ol style="list-style-type: none"> 1. Adjust AM carrier control for suitable output by turning clockwise (about "5" position on the RF meter).
* No output in SSB mode.	<ol style="list-style-type: none"> 1. Microphone plug is improperly connected to the microphone jack. 2. SSB mic volume is set too low. 	<ol style="list-style-type: none"> 1. Firmly seat the microphone plug. 2. Clockwise increase SSB MIC GAIN.
* FM modulation low.	<ol style="list-style-type: none"> 1. FM mic gain set too low. 	<ol style="list-style-type: none"> 1. Turn clockwise increase FM MIC GAIN.

PACKING FOR SHIPMENT

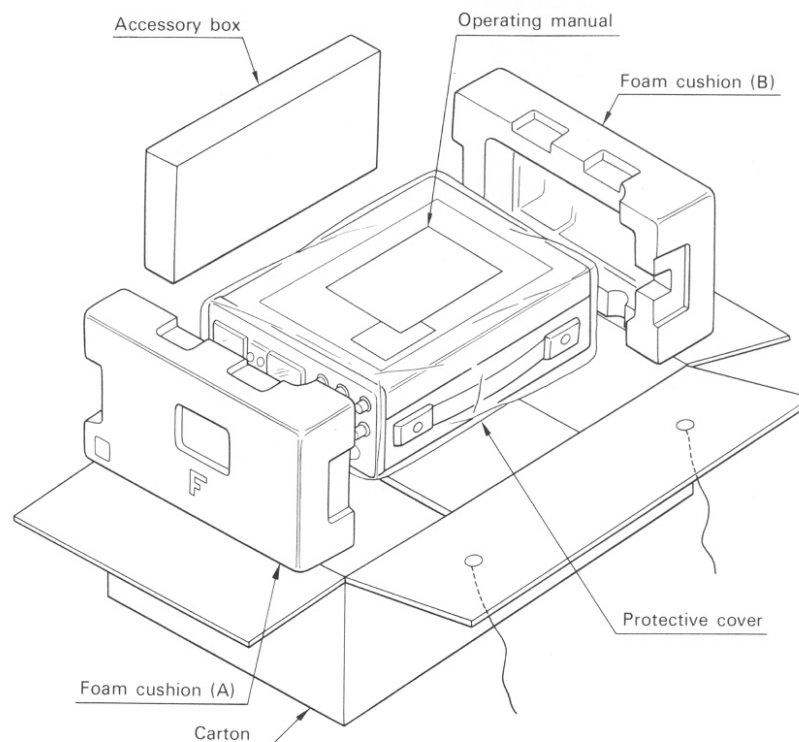

TOP & BOTTOM INTERNAL VIEWS

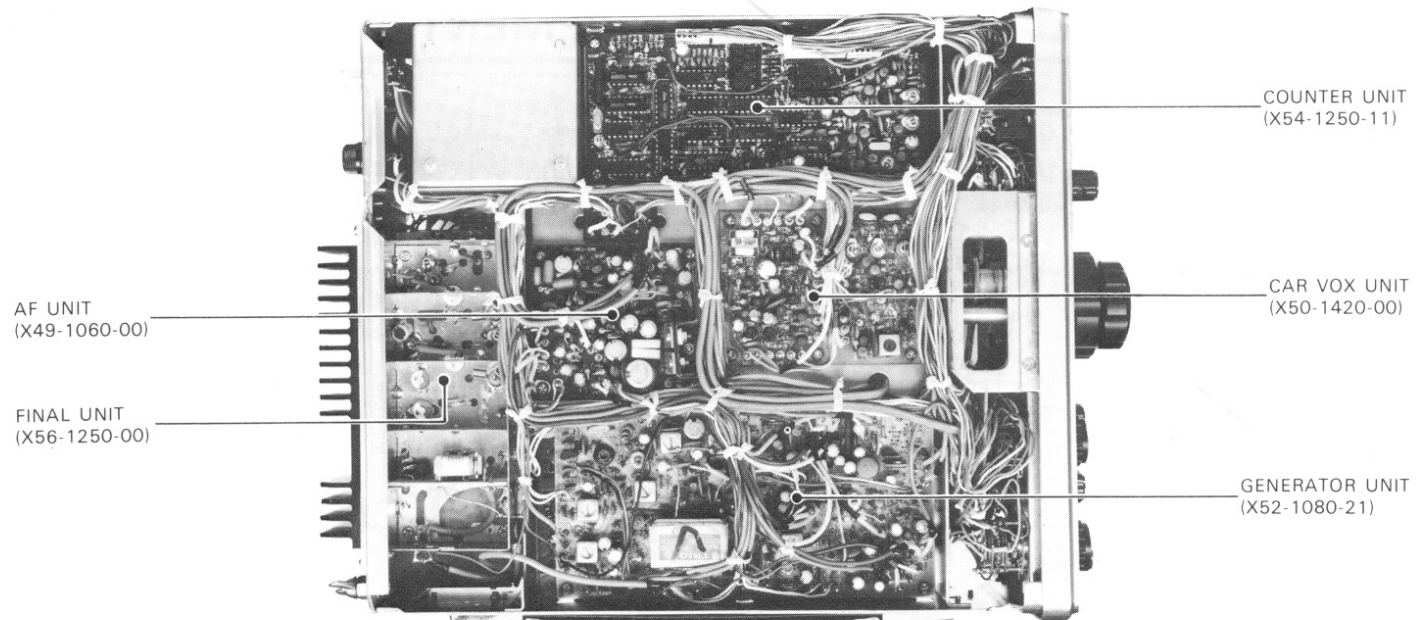
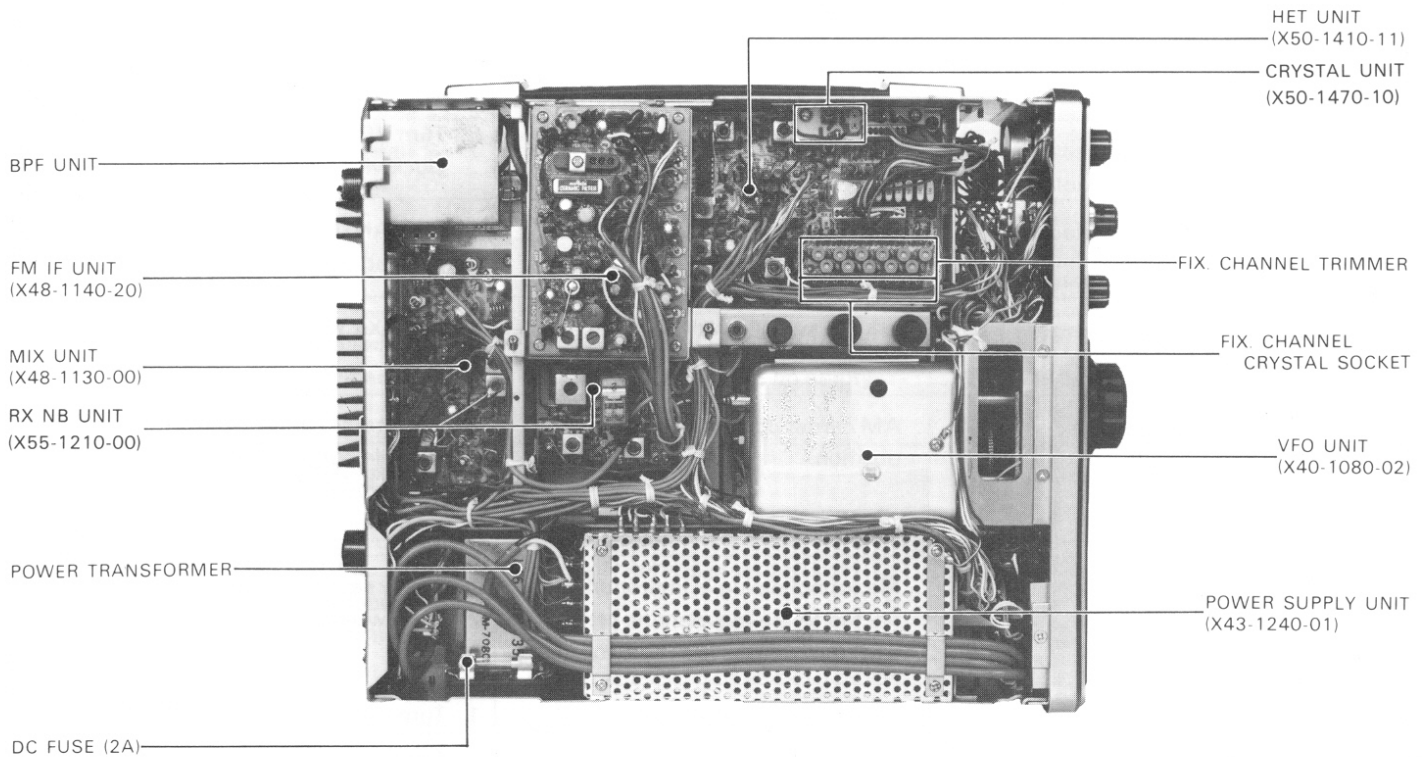

A product of
TRIO-KENWOOD CORPORATION

6-17, 3-chome, Aobadai, Meguro-ku, Tokyo 153, Japan

© 8471 PRINTED IN JAPAN B50-2574-00 (G)

Ⓚ