

Assembly
and
Operation
of the

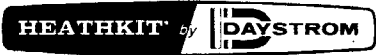

**PHONE
AND CW
TRANSMITTER**

MODEL DX-60



HEATH COMPANY,
BENTON HARBOR,
MICHIGAN



TABLE OF CONTENTS

Specifications.	2
Introduction.	2
Circuit Description.	3
Construction Notes.	5
Parts List.	6
Proper Soldering Techniques.	8
Step-By-Step Procedure.	10
Step-By-Step Assembly.	10
Chassis Parts Mounting.	10
Initial Wiring.	12
Modulator Wiring.	16
Power Supply Wiring.	17
Oscillator Wiring.	18
Final Amplifier Wiring.	18
General Chassis Assembly.	19
Top of Chassis Assembly.	22
Final Wiring.	28
Initial Test And Adjustment.	33
Final Assembly.	35
Operation.	36
Antennas.	36
Operation With Crystals.	36
Operation With VFO.	36
Operating Instructions For CW or AM.	37
Operating Reminders.	37
In Case of Difficulty.	38
Service Information.	39
Service.	39
Replacements.	40
Shipping Instructions.	40
Warranty.	41
Schematic.	41*

*Fold-out from page.

All prices are subject to change without notice. The Heath Company reserves the right to discontinue instruments and to change specifications at any time without incurring any obligation to incorporate new features in instruments previously sold.

SPECIFICATIONS

Power Input:	90 watts CW and controlled-carrier phone.
Output Impedance:	50 - 75 Ω .
Output Coupling:	Pi network (coaxial).
Band Coverage:	80, 40, 20, 15, and 10 meters.
Front Panel Controls:	METER Switch Function Switch DRIVE LEVEL CRYSTAL - VFO Switch (4 crystal positions) DRIVE TUNE BAND Switch FINAL TUNING FINAL LOADING
Tube Complement:	1 - 12AX7, Speech Amplifier 1 - 6DE7, Controlled-Carrier Modulator 1 - 6CL6, Crystal Oscillator 1 - 6CL6, Driver 1 - 6146, Final Amplifier
Power Requirements:	117 volts AC, 50/60 cycles, 225 watts.
Cabinet Size:	13-3/4" wide x 11-1/2" deep x 6-1/2" high.
Net Weight:	23 lbs.
Shipping Weight:	28 lbs.

INTRODUCTION

The HEATHKIT Model DX-60 Transmitter was designed as a versatile and economical transmitter for General and Novice Class amateur operation. It features up to 90 watts input, controlled carrier phone operation, four switched crystal positions, and provisions for the use of a VFO. Panel controls allow for CRYSTAL or VFO, and PHONE or CW operation.

Front panel controls consist of the BAND switch, DRIVE TUNE control, DRIVE LEVEL control, CRYSTAL - VFO switch, FINAL TUNING control, FINAL LOADING control, and Function

switch. The illuminated meter face is calibrated to indicate both grid drive and plate current. A slide switch, directly below the meter, enables the operator to rapidly check grid drive or plate current. The MIKE and KEY jacks are on the front panel for easy accessibility.

An accessory power socket is provided on the rear chassis apron. At this socket, 300 volts at 50 ma DC and 6.3 volts AC are available for VFO operation. Switched 117 volt AC power is also available for antenna relay operation.

CIRCUIT DESCRIPTION

The DX-60 Transmitter has seven basic circuits. These are shown on the Functional Block Diagram. While reading the Circuit Description, we suggest that you follow the circuit on the Block and Schematic Diagrams.

OSCILLATOR

Oscillator tube, stage V1, operates as a modified Pierce crystal oscillator. This oscillator can be operated at the fundamental frequency of either an 80 or 40 meter crystal. When the DX-60 is used with a VFO, V1 operates as a buffer stage. The plate circuit of V1 is untuned for 80 meter operation, and is slug tuned by coil L1 for operation on 40 through 10 meters. The output of V1 is capacitively coupled to driver stage V2 through capacitor C6.

DRIVER

V2 is used as a driver stage. The plate circuit of V2 is tuned to the desired operating frequency by coil L2 and variable capacitor C11.

This stage operates straight-through on 80 and 40 meters, as a doubler on 20, as a tripler on 15, and as a quadrupler on 10 meters. The amount of output (drive) is adjusted by varying the screen voltage of V2 with DRIVE LEVEL control R6. Drive is capacitively coupled to the grid of final amplifier V3 through capacitor C13.

FINAL AMPLIFIER

Final amplifier tube V3 operates on all bands as a shunt-fed, straight-through, neutralized amplifier. The tank circuit consists of C22, L3, and C24. Variable loading capacitor C24 has three 450 $\mu\mu\text{f}$ sections to eliminate the necessity of switching fixed capacity into or out of the circuit when changing bands.

The output is applied to a low-pass filter consisting of L4 through L8, and C25 through C28. This low-pass filter has a cutoff point of approximately 34 mc and suppresses RF energy above this frequency. The output should be fed into an unbalanced 50 to 75 Ω lines.

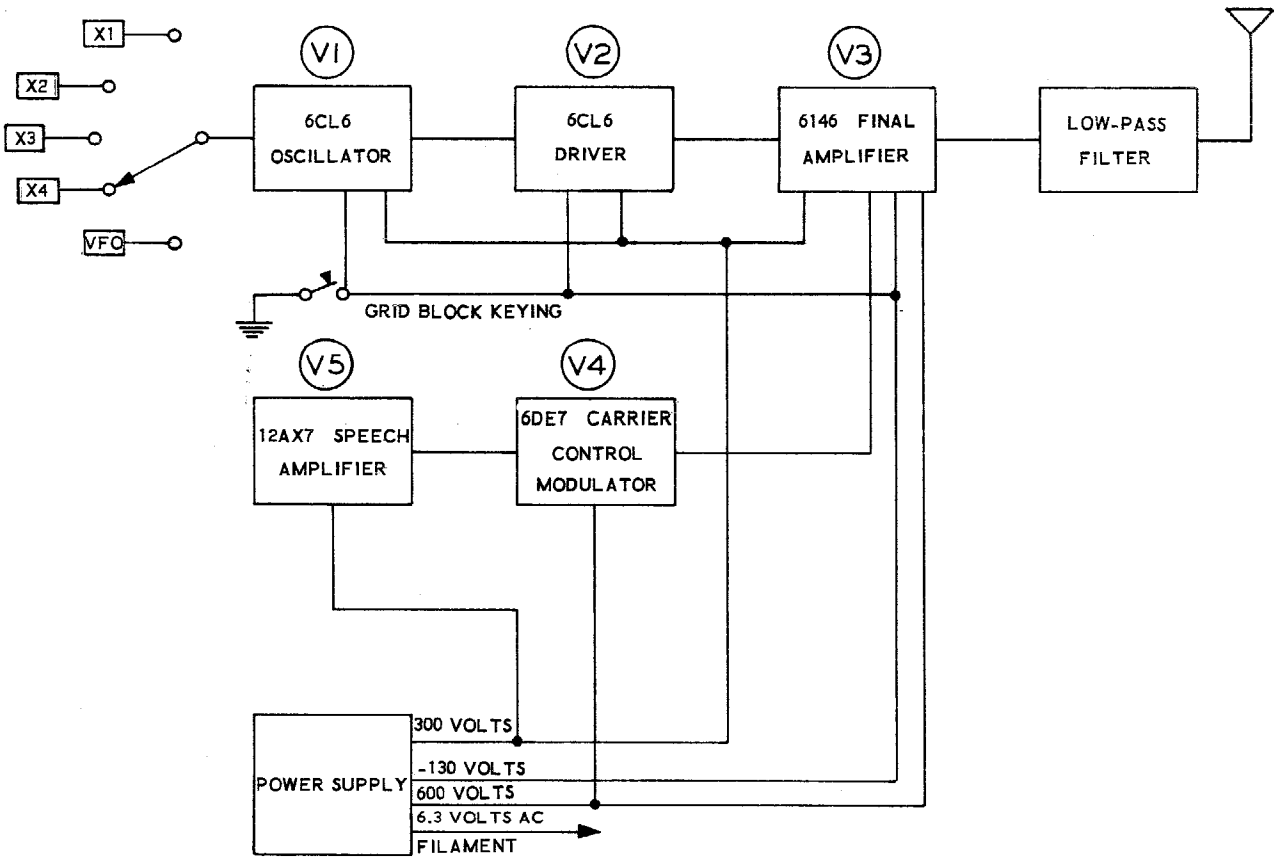

BLOCK DIAGRAM

The cathode and grid currents of the final amplifier are measured with a 0-1 ma meter. The appropriate shunt, R10 and R11 for grid current, or R13 for cathode current, is selected by the METER switch, located on the front panel.

SPEECH AMPLIFIER

Speech amplifier V5 operates as a conventional resistance coupled audio amplifier. The plate of V5 is coupled to one-half of modulator tube V4 through capacitor C33.

MODULATION

Modulator tube V4 contains two dissimilar triodes, one having a power rating of 1.5 watts and the other 7 watts. The lower power section is used as a direct coupled driver to excite the higher rated section, which is actually the modulator. The cathode of the modulator section is coupled to the screen grid of V3, the final amplifier tube, through R32 and C35.

V4 is so biased that with no audio signal the conduction of the tube is limited. This allows the screen voltage of V3 to remain at a low value, thus limiting the plate current of V3 to a low resting state.

With modulation applied, conduction in the modulator section of V4 increases, raising the screen voltage of V3. This results in an increase in final plate current with modulation producing a controlled-carrier effect.

POWER SUPPLY

The power supply section uses four silicon diodes in a voltage-doubler circuit. Filtering is accomplished by capacitors C36, C37, C38, and resistors R18 and R19.

Bias voltage for grid block keying is developed by a silicon diode in a half-wave rectifier circuit.

A separate 6.3 volt, 4 amp winding for VFO filaments or other accessory equipment is available at the accessory power socket.

The line cord uses a fused plug for protection in the event of short circuits or transmitter overload.

GRID BLOCK KEYING

In order to explain grid block keying, it is necessary to consider key-up and key-down conditions. Refer to the following partial schematic diagram.

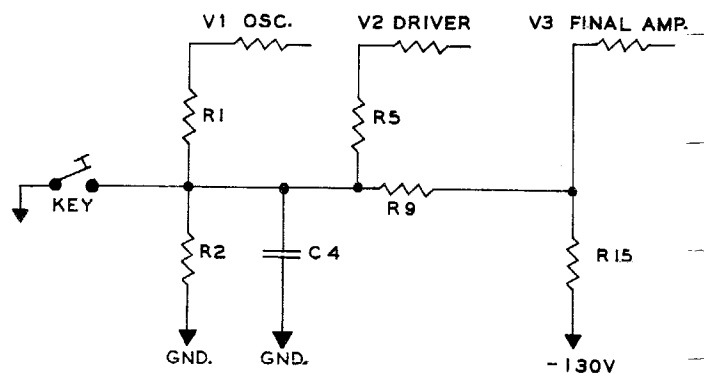

GRID BLOCK KEYING

KEY-UP

A negative voltage is placed on the grids of tubes V1, V2, and V3. Since this bias voltage cuts these tubes off, there can be no transmitter output.

KEY-DOWN

Under this condition, R2 is shorted, removing the bias voltage from V1 and V2. At the same time the bias to V3 is reduced to operating level through resistor R9. Should drive accidentally be removed from the final amplifier, there is adequate fixed bias to protect the tube. The values of C4 and R2 were chosen to provide the most desirable waveform for CW operation.

CONSTRUCTION NOTES

This manual is supplied to assist you in every way to complete your kit with the least possible chance for error. The arrangement shown is the result of extensive experimentation and trial. If followed carefully, the result will be a stable instrument, operating at a high degree of dependability. We suggest that you retain the manual in your files for future reference, both in the use of the instrument and for its maintenance.

UNPACK THE KIT CAREFULLY AND CHECK EACH PART AGAINST THE PARTS LIST. In so doing, you will become acquainted with the parts. Refer to the charts and other information on the inside covers of the manual to help you identify the components. If some shortage or parts damage is found in checking the Parts List, please read the **REPLACEMENT** section and supply the information called for therein. Include all inspection slips in your letter to us.

Resistors generally have a tolerance rating of 10% unless otherwise stated in the Parts List. Tolerances on capacitors are generally even greater. Limits of +100% and -20% are common for electrolytic capacitors.

We suggest that you do the following before work is started:

1. Lay out all parts so that they are readily available.
2. Provide yourself with good quality tools. Basic tool requirements consist of a screw-

driver with a 1/4" blade; a small screwdriver with a 1/8" blade; long-nose pliers; wire cutters, preferably separate diagonal cutters; a pen knife or a tool for stripping insulation from wires; a soldering iron (or gun) and rosin core solder. A set of nut drivers and a nut starter, while not necessary, will aid extensively in construction of the kit.

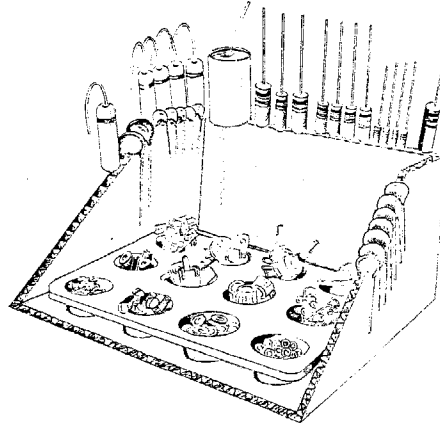

Most kit builders find it helpful to separate the various parts into convenient categories. Muffin tins or molded egg cartons make convenient trays for small parts. Resistors and capacitors may be placed with their lead ends inserted in the edge of a piece of corrugated cardboard until they are needed. Values can be written on the cardboard next to each component. The illustration shows one method that may be used.

PARTS LIST

Refer to the Parts Pictorial, fold-out from Page 9.

<u>PART No.</u>	<u>PARTS Per Kit</u>	<u>DESCRIPTION</u>	<u>PART No.</u>	<u>PARTS Per Kit</u>	<u>DESCRIPTION</u>
<u>Resistors</u>			<u>Capacitors (Cont'd.)</u>		
1-14	1	3300 Ω 1/2 watt (orange-orange-red)	20-101	3	47 $\mu\mu\text{f}$ silver mica
1-16	1	4700 Ω 1/2 watt (yellow-violet-red)	20-102	1	100 $\mu\mu\text{f}$ silver mica
1-22	1	22 K Ω 1/2 watt (red-red-orange)	20-105	2	180 $\mu\mu\text{f}$ silver mica
1-24	2	33 K Ω 1/2 watt (orange-orange-orange)	21-9	3	100 $\mu\mu\text{f}$ disc ceramic
1-25	1	47 K Ω 1/2 watt (yellow-violet-orange)	21-14	3	.001 μfd disc ceramic
1-33	4	470 K Ω 1/2 watt (yellow-violet-yellow)	21-49	1	68 $\mu\mu\text{f}$ disc ceramic
1-35	2	1 megohm 1/2 watt (brown-black-green)	21-57	14	.005 μfd disc ceramic
1-37	1	2.2 megohm 1/2 watt (red-red-green)	21-59	1	.001 μfd feed-through
1-41	1	10 Ω 1/2 watt (brown-black-black)	23-2	2	.005 μfd tubular
1-45	1	220 Ω 1/2 watt (red-red-brown)	23-28	1	.1 μfd tubular
1-69	1	18 K Ω 1/2 watt (brown-gray-orange)	23-81	2	.01 μfd feed-through
1-70	1	22 megohm 1/2 watt (red-red-blue)	25-16	1	20 μfd electrolytic
1-79	2	820 Ω 1/2 watt (gray-red-brown)	25-36	2	40 μfd electrolytic
1-90	1	2000 Ω 1/2 watt (red-black-red)	25-37	1	40-40 μfd electrolytic
1-130	1	8.2 Ω 1/2 watt (gray-red-gold)	25-80	1	20-20 μfd electrolytic
1A-2	1	1000 Ω 1 watt (brown-black-red)	26-31	1	140 $\mu\mu\text{f}$ variable
1A-24	1	4700 Ω 1 watt (yellow-violet-red)	26-45	1	3-gang variable, 452 $\mu\mu\text{f}$ per section
1B-3	2	10 K Ω 2 watt (brown-black-orange)	26-64	1	21 $\mu\mu\text{f}$ variable
1B-4	1	15 K Ω 2 watt (brown-green-orange)	<u>Coils-Chokes-Transformer</u>		
1B-15	1	1000 Ω 2 watt (brown-black-red)	40-86	1	Final amplifier coil
1B-17	1	6800 Ω 2 watt (blue-gray-red)	141-14	1	Coil package consisting of:
1B-18	1	33 K Ω 2 watt (orange-orange-orange)	40-79	1	40 meter oscillator coil
3G-9	2	100 Ω 7 watt wire-wound	40-337	1	Driver plate coil
3Y-3	1	30 K Ω 25 watt wire-wound, center-tapped	40-347	2	.32 μh low-pass filter coil
<u>Capacitors</u>			40-348	2	.44 μh low-pass filter coil
20-48	1	.001 μfd molded mica	40-349	1	.5 μh low-pass filter coil
20-64	1	120 $\mu\mu\text{f}$ molded mica (brown-red-brown)	45-3	1	1 mh RF choke
			45-4	1	1.1 mh RF choke
			45-19	1	Parasitic choke
			45-41	1	.425 μh RF plate choke
			54-109	1	Power transformer
			<u>Controls-Switches</u>		
			10-58	1	100 K Ω control, tab mounting
			11-20	1	25 K Ω control, 4 watt wire-wound
			60-15	1	DPDT slide switch
			63-290	1	5-position, 1-section rotary switch
			63-244	1	5-position, 2-section rotary switch (extended rear wafer)
			63-246	1	5-position, 1-section rotary switch

<u>PART No.</u>	<u>PARTS Per Kit</u>	<u>DESCRIPTION</u>
-----------------	----------------------	--------------------

Terminal Strips*-Sockets-Connectors

*NOTE: Refer to the parts pictorial for identification of these parts.

431-1	1	2-lug terminal strip
431-2	1	2-lug terminal strip
431-10	2	3-lug terminal strip
431-12	2	4-lug terminal strip
431-14	2	2-lug terminal strip
431-27	1	3-lug terminal strip
431-40	1	4-lug terminal strip
431-41	1	2-lug terminal strip
431-42	2	5-lug terminal strip
431-45	1	6-lug terminal strip
432-3	1	Mike connector
434-36	2	9-pin ceramic tube socket
434-38	4	Crystal socket
434-39	2	Octal tube socket
434-42	1	Phono connector
434-43	2	9-pin molded tube socket
434-44	2	Pilot light socket
436-4	1	Phone jack
436-5	1	Coaxial jack

Hardware

250-4	2	4-40 x 3/8" RHMS (round head machine screw)
250-7	3	6-32 x 3/16" RHMS (round head machine screw)
250-8	32	#6 sheet metal screw
250-34	4	4-40 x 1/2" RHMS (round head machine screw)
250-49	12	3-48 x 1/4" BHMS (binder head machine screw)
250-56	52	6-32 x 1/4" BHMS (binder head machine screw)
250-89	8	6-32 x 3/8" BHMS (binder head machine screw)
250-116	4	6-32 x 1/4" truss head screw
250-123	1	10-24 x 2-1/4" hex head screw
250-152	1	10-24 x 3/4" RHMS (round head machine screw)
251-1	10	#6 spade bolt
252-1	12	3-48 nut
252-3	62	6-32 nut
252-4	4	8-32 nut
252-7	8	Control nut
252-15	4	4-40 nut

<u>PART No.</u>	<u>PARTS Per Kit</u>	<u>DESCRIPTION</u>
-----------------	----------------------	--------------------

Hardware (Cont'd.)

252-22	4	#6 speednut
252-30	2	10-24 nut
252-31	1	10-24 wing nut
252-32	2	Push-on speednut
253-1	1	#6 flat fiber washer
253-7	1	#10 shoulder fiber washer
253-9	4	#8 flat steel washer
253-10	5	Control flat washer
253-19	2	#10 flat steel washer
254-1	82	#6 lockwasher
254-2	4	#8 lockwasher
254-3	2	#10 lockwasher
254-4	9	Control lockwasher
254-5	1	Thin control lockwasher
254-7	17	#3 lockwasher
254-9	4	#4 lockwasher
254-10	1	5/16" external lockwasher
255-13	4	#8 spacer
259-1	7	#6 solder lug
259-6	5	#6 small solder lug
259-10	1	Control solder lug

Sheet Metal Parts

90-M152F	1	Top cover
200-M282F419	1	Chassis
203-M216F400-401	1	Front panel
204-M158	1	Meter mounting bracket
204-M356	1	Crystal socket bracket
205-M259	1	Top plate, final amplifier shield
205-M260	1	Chassis bottom plate
205-M269	2	Meter mounting spacer
206-M65	1	Line cord terminal shield
206-M136	1	Oscillator shield
206-M137	1	Driver shield
206-M138	1	Front section of final amplifier shield
206-M139	1	Rear section of final amplifier shield
206-M142	1	Center shield
206-M143	1	Low-pass filter chassis

Shafts-Knobs-Bushings

100-M303	2	Knob pointer assembly
453-25	1	1-3/4" shaft
453-66	1	5" shaft
453-102	1	7-7/8" shaft
455-9	3	3/8" bushing
462-122	5	Skirt knob

<u>PART No.</u>	<u>PARTS Per Kit</u>	<u>DESCRIPTION</u>
-----------------	----------------------	--------------------

Rectifiers-Tubes-Lamps

57-23	1	Silicon diode
57-27	4	Silicon diode
411-26	1	12AX7 tube
411-63	2	6CL6 tube
411-75	1	6146 tube
411-109	1	6DE7 tube
412-1	2	#47 pilot lamp
412-12	1	Clear neon lamp
412-13	1	Red neon lamp

Miscellaneous

71-4	2	Standoff insulator
71-5	3	Standoff insulator with terminal
73-1	2	3/8" rubber grommet
73-4	3	5/16" rubber grommet
89-4	1	Line cord
134-25	1	Cable harness
205-71F	1	Meter escutcheon
206-3	1	2" tube shield
206-54	3	2-3/8" tube shield
260-10	1	Ceramic plate cap

<u>PART No.</u>	<u>PARTS Per Kit</u>	<u>DESCRIPTION</u>
-----------------	----------------------	--------------------

Miscellaneous (Cont'd.)

261-9	4	Rubber feet
340-1	1	Length #14 bare wire
340-2	1	Length #20 bare wire
344-1	5	Lengths #22 hookup wire: 1-yellow, 1-red, 1-black, 1-brown, and 1-white.
344-6	1	Length #18 red hookup wire
346-1	1	Length insulating sleeving
407-76	1	0-1 ma meter
421-2	2	3 amp 3AG fuse
438-11	1	AC fuse plug
456-1	1	Flexible coupler
456-7	2	1/4" shaft coupler
481-1	1	Capacitor mounting wafer
331-6		Solder
595-365	1	Manual

NOTE: It is necessary to construct a "dummy load" to test this unit. A coaxial connector, such as the Amphenol Type PL-259, and a 75 watt light bulb is required. You may wish to purchase these now to avoid delay after construction.

PROPER SOLDERING TECHNIQUES

Only a small percentage of HEATHKIT equipment purchasers find it necessary to return an instrument for factory service. Of these instruments, by far the largest portion of malfunctions are due to poor or improper soldering.

If terminals are bright and clean and free of wax, frayed insulation and other foreign substances, no difficulty will be experienced in soldering. Correctly soldered connections are essential if the performance engineered into a kit is to be fully realized. If you are a beginner with no experience in soldering, a half hour's practice with some odd lengths of wire may be a worthwhile investment.

For most wiring, a 30 to 100 watt iron or its equivalent in a soldering gun is very satisfactory. A lower wattage iron than this may not heat the connection enough to flow the solder smoothly over the joint. Keep the iron tip clean and bright by wiping it from time to time with a cloth.

CHASSIS WIRING AND SOLDERING

1. Unless otherwise indicated, all wire used is the type with colored insulation (hookup wire). In preparing a length of hookup wire, 1/4" of insulation should be removed from each end unless directed otherwise in the construction step.
2. To avoid breaking internal connections when stripping insulation from the leads of transformers or similar components, care should be taken not to pull directly on the lead. Instead, hold the lead with pliers while it is being stripped.
3. Leads on resistors, capacitors and similar components are generally much longer than they need to be to make the required connections. In these cases, the leads should be cut to proper length before the part is added to the chassis. In general, the leads should be just long enough to reach their terminating points.

4. Wherever there is a possibility of bare leads shorting to other parts or to the chassis, the leads should be covered with insulating sleeving. Where the use of sleeving is specifically intended, the phrase "use sleeving" is included in the associated construction step. In any case where there is the possibility of an unintentional short circuit, sleeving should be used. Extra sleeving is provided for this purpose.
5. Crimp or bend the lead (or leads) around the terminal to form a good joint without relying on solder for physical strength. If the wire is too large to allow bending or if the step states that the wire is not to be crimped, position the wire so that a good solder connection can still be made.
6. Position the work, if possible, so that gravity will help to keep the solder where you want it.
7. Place a flat side of the soldering iron tip against the joint to be soldered until it is heated sufficiently to melt the solder.
8. Then place the solder against the heated terminal and it will immediately flow over the joint; use only enough solder to thoroughly wet the junction. It is usually not necessary to fill the entire hole in the terminal with solder.
9. Remove the solder and then the iron from the completed junction. Use care not to move the leads until the solder is solidified.

A poor or cold solder joint will usually look crystalline and have a grainy texture, or the solder will stand up in a blob and will not have adhered to the joint. Such joints should be reheated until the solder flows smoothly over the entire junction. In some cases, it may be necessary to add a little more solder to achieve a smooth bright appearance.

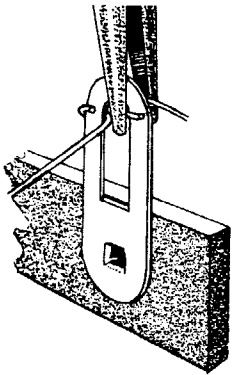

CRIMP WIRES

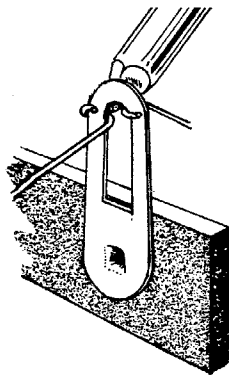

HEAT CONNECTION

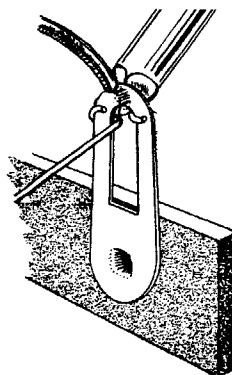

APPLY SOLDER

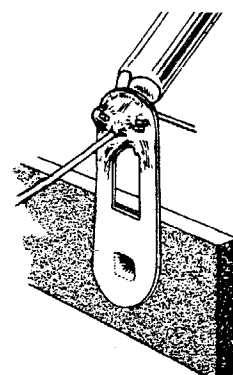

ALLOW SOLDER TO FLOW

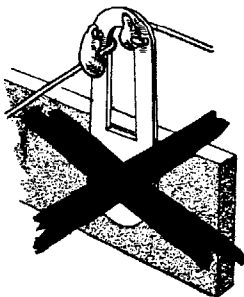

COLD SOLDER JOINT CONNECTION INSUFFICIENTLY HEATED

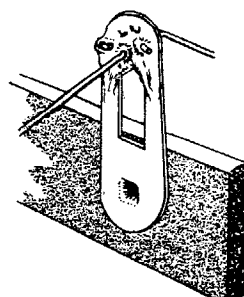

PROPER SOLDER CONNECTION

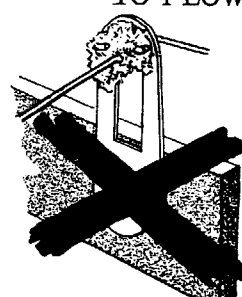

COLD SOLDER JOINT CONNECTION MOVED WHILE COOLING

ROSIN CORE SOLDER HAS BEEN SUPPLIED WITH THIS KIT. THIS TYPE OF SOLDER MUST BE USED FOR ALL SOLDERING IN THIS KIT. ALL GUARANTEES ARE VOIDED AND WE WILL NOT REPAIR OR SERVICE EQUIPMENT IN WHICH ACID CORE SOLDER OR PASTE FLUXES HAVE BEEN USED. IF ADDITIONAL SOLDER IS NEEDED, BE SURE TO PURCHASE ROSIN CORE (60:40 or 50:50 TIN-LEAD CONTENT) RADIO TYPE SOLDER.

STEP-BY-STEP PROCEDURE

The following instructions are presented in a logical step-by-step sequence to enable you to complete your kit with the least possible confusion. Be sure to read each step all the way through before beginning the specified operation. Also read several steps ahead of the actual step being performed. This will familiarize you with the relationship of the subsequent operations. When the step is completed, check it off in the space provided. This is particularly important as it may prevent errors or omissions, especially if your work is interrupted. Some kit builders have also found it helpful to mark each lead in colored pencil on the Pictorial as it is added.

The fold-out diagrams in this manual may be removed and attached to the wall above your working area; but, because they are an integral part of the instructions, they should be returned to the manual after the kit is completed.

In general, the illustrations in this manual correspond to the actual configuration of the kit; however, in some instances the illustra-

tions may be slightly distorted to facilitate clearly showing all of the parts.

The abbreviation "NS" indicates that a connection should not be soldered yet as other wires will be added. When the last wire is installed, the terminal should be soldered and the abbreviation "S" is used to indicate this. Note that a number will appear after each solder instruction. This number indicates the number of leads that are supposed to be connected to the terminal in point before it is soldered. For example, if the instruction reads, "Connect a lead to lug 1 (S-2)," it will be understood that there will be two leads connected to the terminal at the time it is soldered. (In cases where a lead passes through a terminal or lug and then connects to another point, it will count as two leads, one entering and one leaving the terminal.)

The steps directing the installation of resistors include color codes to help identify the parts. Also, if a part is identified by a letter-number designation on the Schematic, its designation will appear in the construction step which directs its installation.

STEP-BY-STEP ASSEMBLY

CHASSIS PARTS MOUNTING

Refer to Pictorial 1 for the following steps.

- (1) Referring to Detail 1A, mount a ceramic tube socket and #6 small solder lug at V1 and at V2. Use 3-48 screws, #3 lockwashers, and 3-48 nuts. Orient the blank spaces as shown by the arrows in Pictorial 1 and bend the solder lugs up, as shown.

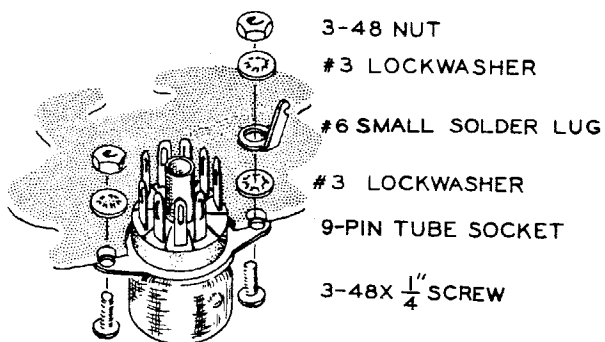

Detail 1A

- (2) Mount a molded 9-pin tube socket at V4 and at V5. Use two #6 small solder lugs at V5 and one #6 small solder lug at V4 as shown. Orient the blank space as shown by the arrows.

NOTE: The phrase "#6 hardware" means 6-32 x 1/4" screws, #6 lockwashers, and 6-32 nuts.

- (3) Referring to Detail 1B, mount an octal tube socket at V3. Use #6 hardware. Orient the keyway as shown by the arrow in Pictorial 1.

NOTE: Wherever terminals strips are mounted please refer to the proper pictorial and the parts pictorial to avoid error in selecting the proper part. Position exactly as shown to avoid wiring errors.

- (4) Mount a 5-lug high-voltage terminal strip at location E. Use #6 hardware. The high voltage terminal strips have wider lug spacing and a larger mounting foot than the other terminal strips. See Detail 1D.

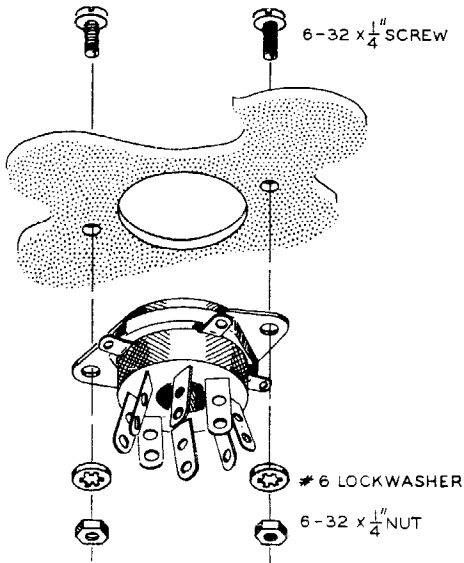

Detail 1B

(E) Similarly, mount high-voltage terminal strips F and G. Use #6 hardware.

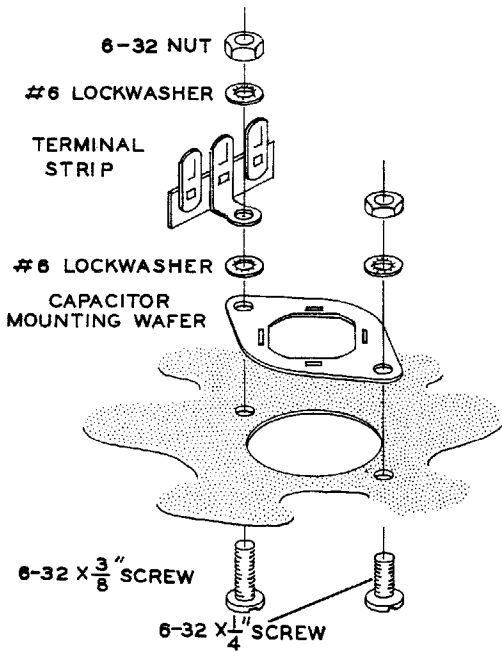

Detail 1C

(E) Referring to Detail 1C, mount the capacitor mounting wafer at K and a 3-lug terminal strip at J. Use a 6-32 x 3/8" screw, two #6 lockwashers, and a 6-32 nut for the double mounting, and use #6 hardware for the single mounting. The capacitor mounting wafer should be installed on the underside of the chassis as shown.

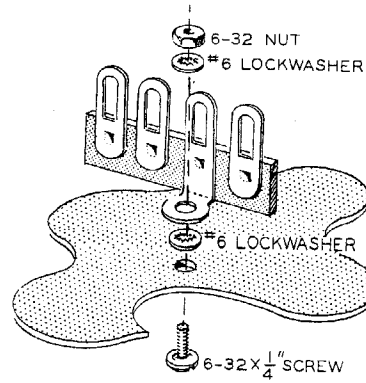

Detail 1D

(E) Referring to Detail 1D, mount a 4-lug terminal strip at A. Note the position of the mounting foot to be sure that the correct 4-lug terminal strip is used. Use #6 hardware.

(E) Similarly, mount terminal strips C, L, M, and N. Use #6 hardware.

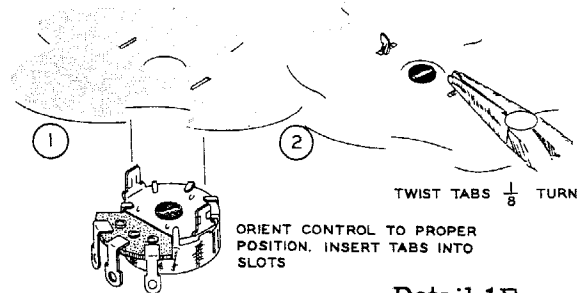

Detail 1E

(A) R26. Referring to Detail 1E, mount 100 KΩ tab-mounting control D (#10-58). Secure the control by twisting each tab 1/8 turn.

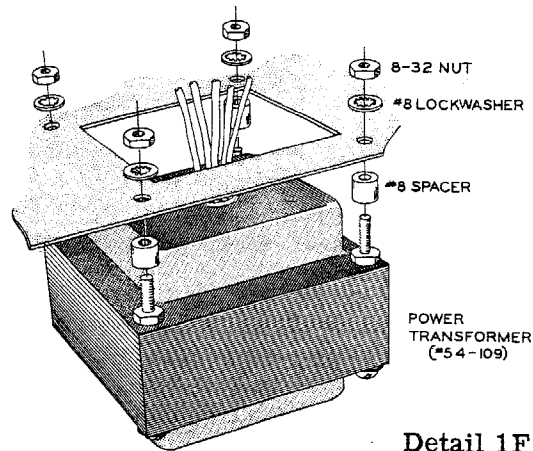

Detail 1F

(E) Referring to Detail 1F, mount the power transformer. Use #8 spacers, #8 lockwashers, and 8-32 nuts. Place the spacers over the transformer studs as shown.

- () C37A, C37B. Mount electrolytic capacitor K (#25-37) with the \blacktriangle and \blacktriangle lug marks oriented as shown in Pictorial 1. Secure the capacitor by twisting each mounting tab $1/8$ turn.
- () Install $5/16$ " grommets at B, P, and Q.
- () Similarly, install a $3/8$ " grommet at H.
- () Mount the remaining octal tube socket at BE. Use #6 hardware. Orient the keyway as shown by the arrow in Pictorial 1.

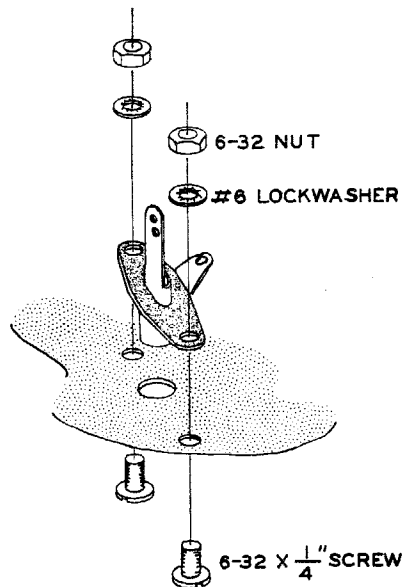

Detail 1G

- () Mount the female phono connector at BF. Use #6 hardware. See Detail 1G.
- () Mount the #10 x $3/4$ " ground bolt at BG. Use two #10 lockwashers, one on each side of the chassis rear apron, and a #10 nut. Now, place two flat steel washers over the bolt and secure them with the wing nut.
- () Referring to Detail 1H, locate the front panel and loosely fasten it to the chassis with microphone connector AA. Use a control lockwasher and control nut. Discard the solder lug supplied with the connector. Do not tighten securely yet.
- () Fasten the center of the front panel to the chassis with bushings AD and AE. Use a control lockwasher and control nut on each

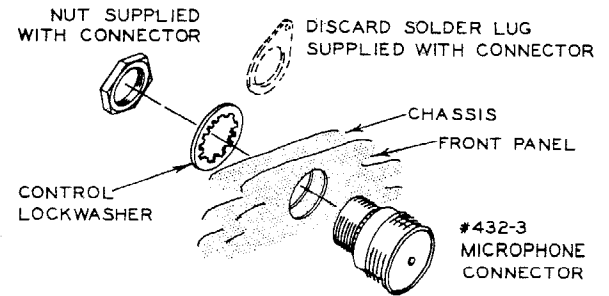

Detail 1H

bushing. Now securely tighten AA, AD, and AE. Center the front panel holes.

- () Install the red neon pilot lamp below hole AG. Use a large push-on speednut.
- () Similarly, install the clear neon pilot lamp below AA.
- () Place four #6 speednuts on the sides of the chassis as shown in Pictorial 1. Be sure that the flat sides of the speednuts face outward.

INITIAL WIRING

Refer to Pictorial 2 for the following steps.

- () Connect a length of small bare wire between lug 1 of accessory power socket BE (S-1) and the ground lug nearest lug 1 of BE (S-1).
- () Referring to Detail 2A, shape the wiring harness as shown.
- () Place the harness in the chassis bottom with the end containing the long red and yellow wires near hole AG.
- () Place Function switch AB (#63-246) in the approximate position shown on the chassis. Note position of the switch lugs.
- () Connect the white harness wire coming from breakout point B to lug 9 of switch AB (S-1).
- () Connect either of the black harness wires coming from breakout point B to lug 11 of switch AB (S-1).
- () Connect the other black harness wire coming from breakout point B to lug 12 of switch AB (S-1). Examine all switch connections to be sure they are correct before proceeding.

- () Orient the switch at AB as shown in Pictorial 2, and secure it with a control lock-washer on the switch bushing and a control flat washer and control nut on the front panel.
- () R6. Similarly, mount the DRIVE LEVEL control (#11-20) at AC. Use a control solder lug on the bushing with a control flat washer and control nut on the front panel. Position the control solder lug as shown in Pictorial 2.

NOTE: The following connections will be made using the wires coming from the harness breakout points.

BREAKOUT POINT A:

- () Either red wire to lug 4 of switch AB (S-1).
- () The other red wire to lug 5 of switch AB (S-1).
- () Orange wire to lug 2 of control AC (S-1).
- () Place the gray and green wires through grommet B to be connected later.

BREAKOUT POINT B:

- () Orange wire to lug 3 of switch AB (S-1).
- () Red wire to lug 4 of terminal strip A (NS).
- () Gray wire to lug 3 of terminal strip A (NS).
- () Either yellow wire to lug 7 of switch AB (S-1).
- () Other yellow wire to lug 8 of switch AB (S-1).

BREAKOUT POINT C:

- () Yellow wire to lug 1 of terminal strip C (NS).
- () Brown wire to lug 5 of tube socket V5 (NS).

BREAKOUT POINT D:

- () Yellow wire to lug 2 of terminal strip F (NS).
- () Red wire to lug 4 of terminal strip F (NS).

BREAKOUT POINT E:

- () Red wire to lug 1 of terminal strip J (NS).

- () Large black wire to lug 3 of terminal strip J (NS).
- () Both brown wires to lug 3 of terminal strip J (NS).
- () Both yellow wires to lug 8 of accessory power socket BE (S-2).
- () Leave the two remaining black wires free. They will be connected later.

BREAKOUT POINT F:

- () Large red wire to lug 2 of terminal strip G (NS).
- () Both red wires to lug 2 of electrolytic capacitor K (NS).
- () White wire to lug 5 of accessory power socket BE (S-1).

BREAKOUT POINT G:

- () Both brown wires to lug 5 of tube socket V1 (NS).

BREAKOUT POINT H:

- () Both red wires to lug 3 of terminal strip M (NS).
- () Both yellow wires to lug 4 of terminal strip M (NS).

BREAKOUT POINT J:

- () Yellow wire to lug 2 of terminal strip N (NS).
- () Red wire to lug 3 of terminal strip N (NS).
- () Green wire to lug 5 of terminal strip N (NS).
- () Gray wire to lug 6 of terminal strip N (NS).
- () Brown wire to lug 5 of tube socket V2 (NS). Dress as shown.
- () Orange wire to lug 8 of tube socket V2 (NS). Dress as shown.

BREAKOUT POINT K:

- () Large black wire to lug 2 of tube socket V3 (NS).
- () Orange wire to lug 3 of tube socket V3 (NS).
- () Gray wire to lug 6 of tube socket V3 (NS).
- () Leave the large red wire and the yellow wire free. They will be connected later.

Harness wiring connections are now complete with the exception of the two black wires at breakout point E, and the large red wire and yellow wire at breakout point K.

Cut the power transformer leads to the following lengths:

<u>COLOR</u>	<u>LENGTH</u>
() Brown	3-1/4"
() Brown	3"
() Red	2-3/4"
() Red	5"
() Green-yellow	2-1/2"
() Blue-yellow	2-1/2"
() Blue	3"
() Yellow	3-1/2"
() Either black	2-1/2"
() Other black	3"

() Strip 1/4" of insulation from the end of each lead and "tin."

Connect the power transformer leads as follows:

<u>COLOR</u>	<u>CONNECT TO</u>
() Long brown	lug 1 of terminal strip F (NS).
() Short brown	lug 2 of terminal strip F (NS).
() Short red	lug 1 of terminal strip J (S-2).
() Green-Yellow	lug 2 of terminal strip J (NS).
() Blue-Yellow	lug 2 of terminal strip J (S-2).
() Blue	lug 3 of terminal strip J (S-4).
() Long red	lug 1 of electrolytic capacitor K (NS).
() Yellow	lug 2 of accessory power socket BE (S-1).

() Leave the black leads free at this time. They will be connected later.

() Connect a 3" large red hookup wire from lug 5 of tube socket V3 (S-1) to lug 1 of terminal strip N (NS). Dress this wire as shown in Pictorial 2.

() Connect a 4" large red hookup wire from lug 2 of terminal strip G (NS) to lug 1 of tube socket V4 (NS).

() Connect one end of a 4-1/2" large red hookup wire to lug 2 of terminal strip G (NS). Place the other end through grommet H to be connected later.

() Connect a 2-1/2" large red hookup wire from lug 1 of terminal strip G (NS) to lug 5 of terminal strip F (NS).

NOTE: In the following steps, use small hookup wire unless large wire is specifically called for.

() Connect a 9-1/4" yellow hookup wire from lug 2 of terminal strip N (NS) to lug 1 of terminal strip L (NS).

- (✓) Connect one end of a 4-1/2" yellow hookup wire to lug 3 of terminal strip A (NS). Place the other end through grommet B to be connected later.
- (✓) Connect one end of a 5" black hookup wire to ground lug 3 of electrolytic capacitor K (S-1). (Apply enough solder and heat to obtain a good connection between the mounting lug and wafer.) Place the other end of this wire through grommet H to be connected later.
- (✓) Connect one end of a 6-1/4" red hookup wire (small) to lug 2 of electrolytic capacitor K (NS). Place the other end of this wire through grommet H to be connected later.
- () Connect one end of a 4-1/2" black hookup wire to lug 3 of control AC (NS). Place the other end through grommet B to be connected later.
- (✓) Connect one end of a 7-1/2" brown hookup wire to lug 4 of tube socket V4 (NS). Place the other end through grommet B to be connected later.
- () Strip 1/2" of insulation from one end of a 4-1/2" brown hookup wire. Pass this end through lug 4 (NS) to lug 5 (S-2) of tube socket V5. Now, solder lug 4 (S-2). Strip 1/4" of insulation from the other end and connect it to lug 4 of tube socket V4 (S-2).
- (✓) Connect a length of small bare wire from lug 2 of control D (S-1) to lug 2 of tube socket V5 (NS).
- (✓) Connect a length of small bare wire from lug 8 (S-1) to the center post (NS) of tube socket V5.
- () Connect a length of small bare wire between lug 8 (S-1) and ground lug 12 (NS) of tube socket V3.
- () Connect a length of small bare wire between lug 7 (S-1) and ground lug 12 (NS) of tube socket V3.
- () Connect either lead of the clear neon pilot lamp to lug 1 of terminal strip A (NS). Use sleeving.
- () Connect the other lead to lug 2 of terminal strip A (NS).

This completes initial wiring of the chassis.

MODULATOR WIRING

Refer to Pictorial 3 for the following steps.

- () C29. Connect a 100 μf disc ceramic capacitor between lugs 2 (NS) and 3 (S-1) of terminal strip C. Position as shown.
- () C30. Connect a .001 μf disc ceramic capacitor from lug 2 of terminal strip C (NS) to lug 7 of tube socket V5 (NS). Position as shown.
- () C43. Wrap one lead of a .001 μf disc ceramic capacitor around the solder lug nearest lug 8 of tube socket V5 (NS), and then place the end of this lead through lug 9 (NS) to the center post (S-2) of V5. Now, solder lug 9 of V5 (S-2). Connect the other lead of this capacitor to lug 2 of tube socket V5 (S-2). Keep these leads short.
- () C34. Pass one lead of a 100 μf disc ceramic capacitor through lug 8 (NS) to the center post (NS) of tube socket V4. Connect the other lead of this capacitor to lug 9 of V4 (NS).
- () R31. Connect a 33 K Ω (orange-orange-orange) 2 watt resistor between lugs 8 (S-3) and 9 (NS) of tube socket V4.
- (✓) R30. Pass one lead of a 1 megohm (brown-black-green) 1/2 watt resistor through lug 2 (NS) to lug 6 (S-1) of tube socket V4. Use sleeving. Now, solder lug 2 of V4 (S-2). Connect the other lead of this resistor to lug 1 of V4 (S-2).
- () R29. Wrap one lead of a 22 megohm (red-red-blue) 1/2 watt resistor around the solder lug nearest lug 5 of tube socket V4 (NS), then place the end of this lead through lug 5 (NS) to the center post (S-2) of V4. Now, solder lug 5 of V4 (S-2) and the solder lug (S-2). Connect the other lead of this resistor to lug 7 of V4 (NS).
- () R28. Connect a 3300 Ω (orange-orange-red) 1/2 watt resistor from lug 3 of tube socket V5 (S-1) to the solder lug near lug 5 of V5 (S-1).
- (✓) R24. Wrap one lead of a 2.2 megohm (red-red-green) 1/2 watt resistor around the solder lug nearest lug 9 of tube socket V5 (NS). Connect the end of this lead to lug 1 of control D (S-1). Now, solder the solder lug (S-4). Connect the other lead of this resistor to lug 7 of V5 (S-2).
- (✗) R25. Connect a 470 K Ω (yellow-violet-yellow) 1/2 watt resistor from lug 6 of tube socket V5 (NS) to lug 4 of terminal strip C (NS).
- (✗) R27. Connect another 470 K Ω (yellow-violet-yellow) 1/2 watt resistor from lug 1 of tube socket V5 (NS) to lug 4 of terminal strip C (NS).
- (✗) R33. Connect a 33 K Ω (orange-orange-orange) 1/2 watt resistor from lug 4 of terminal strip C (NS) to lug 4 of terminal strip A (NS).
- (✓) R15. Connect a 22 K Ω (red-red-orange) 1/2 watt resistor from lug 1 of terminal strip C (NS) to lug 3 of terminal strip A (S-3).
- (✓) R14. Connect a 470 K Ω (yellow-violet-yellow) 1/2 watt resistor from lug 1 of terminal strip C (S-3) to lug 1 of terminal strip A (S-2).

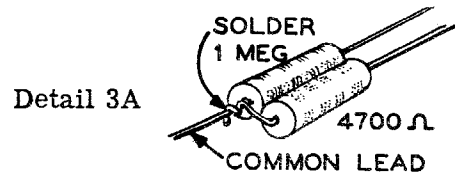

- (✗) R22, R23. Prepare a 1 megohm (brown-black-green) 1/2 watt and 4700 Ω (yellow-violet-red) 1/2 watt resistor combination as shown in Detail 3A. Connect the common lead of this combination to the eyelet in the center of microphone jack AA (S-1). Use sleeving on this lead.
- (✗) Connect the free lead of the 1 megohm (brown-black-green) resistor to lug 2 of terminal strip A (S-2).

- (X) Connect the free lead of the 4700 Ω (yellow-violet-red) resistor to lug 2 of terminal strip C (S-3). Use sleeving.
- (X) R21. Connect a 10 K Ω (brown-black-orange) 2 watt resistor from lug 4 of terminal strip A (NS) to lug 1 of switch AB (S-1).
- (X) C32. Connect the positive (+) lead of a 20 μ fd tubular electrolytic capacitor to lug 4 of terminal strip C (S-4). Connect the other lead of this capacitor to lug 3 of control AC (S-2). Also solder lug 3 of AC to the control solder lug.
- (X) C31. Connect a .005 μ fd tubular capacitor from lug 3 of control D (S-1) to lug 6 of tube socket V5 (S-2). Use sleeving on the lead to lug 6 of V5.
- (X) C33. Connect another .005 μ fd tubular capacitor from lug 1 of tube socket V5 (S-2) to lug 7 of tube socket V4 (S-2). Use sleeving on both leads.
- (X) R7. Connect a 6800 Ω (blue-gray-red) 2 watt resistor from lug 4 of terminal strip A (S-4) to lug 1 of control AC (S-1). Use sleeving on both leads.
- (X) R32, C35. Prepare a 10 K Ω (brown-black-orange) 2 watt resistor and .1 μ fd tubular capacitor combination as shown in Detail 3B.

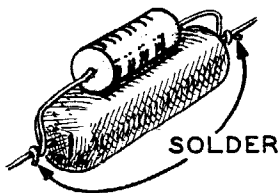

Detail 3B

- (X) Connect this combination from lug 9 of tube socket V4 (S-3) to lug 2 of switch AB (S-1). Use sleeving on both leads.

This completes wiring of the modulator section.

POWER SUPPLY WIRING

Refer to Pictorial 3 for the following steps.

- (X) R17. Connect a 220 Ω (red-red-brown) 1/2 watt resistor between lugs 2 (NS) and 3 (NS) of terminal strip E.
- (X) C39A, C39B. Connect either positive (+) lead of the 20-20 μ fd tubular electrolytic capacitor to lug 2 of terminal strip E (NS). Connect the other positive (+) lead of this capacitor to lug 3 of terminal strip E (S-2).
- (X) Connect the remaining lead of this capacitor to lug 2 of terminal strip F (S-3).
- (X) R33. Connect a 10 Ω (brown-black-black) 1/2 watt resistor between lugs 1 (NS) and 2 (S-3) of terminal strip E.
- (X) D5. Connect the positive (red +) lead of the #57-23 silicon diode to lug 1 of terminal strip E (S-2). Connect the other lead to lug 1 of terminal strip F (S-2).
- (X) D4. Connect the positive (yellow +) lead of a #57-27 silicon diode to lug 4 of terminal strip E (NS). Connect the other lead to lug 3 of terminal strip F (S-1).
- (X) D3. Connect the positive lead of a #57-27 silicon diode to lug 4 of terminal strip F (NS). Connect the other lead to lug 4 of terminal strip E (S-2).
- (X) D2. Connect the positive lead of a #57-27 silicon diode to lug 5 of terminal strip E (NS). Connect the other lead to lug 4 of terminal strip F (S-3).
- (X) D1. Connect the positive lead of the last #57-27 silicon diode to lug 5 of terminal strip F (S-2). Connect the other lead to lug 5 of terminal strip E (S-2).
- (X) C38. Connect the positive (+) lead of a 40 μ fd tubular electrolytic capacitor to lug 1 of terminal strip G (NS). Connect the other lead to lug 1 of electrolytic capacitor K (NS). Use sleeving on the lead to K.
- (X) C36. Connect the positive (+) lead of a 40 μ fd tubular electrolytic capacitor to lug 2 of terminal strip G (NS). Connect the other lead to lug 2 of electrolytic capacitor K (NS). Use sleeving on the lead to K.
- (X) R18. Connect a 100 Ω 7 watt resistor between lugs 1 (S-3) and 2 (S-5) of terminal strip G.
- (X) R19. Connect a 100 Ω 7 watt resistor between lugs 1 (S-3) and 2 (NS) of electrolytic capacitor K.

OSCILLATOR WIRING

Refer to Pictorial 3 for the following steps.

- (X) C3. Wrap one lead of a .005 μ fd disc ceramic capacitor around the solder lug nearest lug 4 of tube socket V1. Pass the end of this lead through lug 4 (NS) to the center post (NS) of V1. Now, solder the solder lug (S-2) and lug 4 (S-2) of V1. Connect the other lead of this capacitor to lug 5 of V1 (S-3). Keep the leads short.
- (X) C2. Place one lead of a 100 μ fd disc ceramic capacitor through lug 7 (NS), through the center post (NS) to lug 1 (S-1) of tube socket V1. Now, solder lug 7 (S-2) and the center post (S-3) of V1. Connect the other lead of this capacitor to lug 8 of V1 (NS).
- (X) C5. Connect a .005 μ fd disc ceramic capacitor between lugs 1 (NS) and 2 (NS) of terminal strip M.
- (X) C4. Connect another .005 μ fd disc ceramic capacitor between lugs 2 (NS) and 4 (NS) of terminal strip M.
- (X) R3. Connect a 15 K Ω (brown-green-orange) 2 watt resistor from lug 3 of terminal strip M (NS) to lug 8 of tube socket V1 (NS).
- (X) R1. Connect a 47 K Ω (yellow-violet-orange) 1/2 watt resistor from lug 4 of terminal strip M (NS) to lug 9 of tube socket V1 (S-1).
- (X) R2. Connect a 33 K Ω (orange-orange-orange) 1/2 watt resistor between lugs 2 (S-3) and 4 (S-5) of terminal strip M.
- (X) R4. Connect a 1000 Ω (brown-black-red) 1 watt resistor between lugs 1 (NS) and 3 (S-4) of terminal strip M.
- (X) C12. Connect a .005 μ fd disc ceramic capacitor between lugs 3 (NS) and 4 (NS) of terminal strip N.
- (X) C14. Connect another .005 μ fd disc ceramic capacitor between lugs 4 (NS) and 5 (NS) of terminal strip N.
- (X) R10. Connect an 820 Ω (gray-red-brown) 1/2 watt resistor between lugs 5 (NS) and 6 (NS) of terminal strip N.
- (X) R11. Connect another 820 Ω (gray-red-brown) 1/2 watt resistor between lugs 5 (NS) and 6 (NS) of terminal strip N.
- (X) R9. Connect a 4700 Ω (yellow-violet-red) 1 watt resistor between lugs 2 (S-3) and 6 (S-4) of terminal strip N.
- (X) C8. Wrap one lead of a .005 μ fd disc ceramic capacitor around the solder lug nearest lug 4 of tube socket V2. Pass the end of this lead through lug 4 of V2 (NS) to the center post of V2 (NS). Now, solder the solder lug (S-2) and lug 4 of V2 (S-2). Connect the other lead of this capacitor to lug 5 of V2 (S-2).
- (X) C9. Place one lead of a .005 μ fd disc ceramic capacitor through lug 7 (NS), through the center post (NS) to lug 1 (S-1) of tube socket V2. Now, solder lug 7 (S-2) and the center post (S-3) of V2. Connect the other lead of this capacitor to lug 8 of V2 (S-2).
- (X) Connect the RF choke (#45-3) from lug 9 of tube socket V2 (NS) to lug 3 of terminal strip L (NS).
- (X) C7. Connect a .005 μ fd disc ceramic capacitor between lugs 2 (S-1) and 3 (NS) of terminal strip L.
- (X) R5. Connect a 18 K Ω (brown-gray-orange) 1/2 watt resistor between lugs 1 (S-2) and 3 (S-3) of terminal strip L.

FINAL AMPLIFIER WIRING

Refer to Pictorial 3 for the following steps. Keep leads as short as possible.

- (X) C17. Connect a .005 μ fd disc ceramic capacitor between lugs 1 (S-1) and ground lug 9 (NS) of tube socket V3.
- (X) C19. Connect a .005 μ fd disc ceramic capacitor between lugs 2 (S-2) and ground lug 9 (S-2) of tube socket V3.
- (X) C42. Connect a .005 μ fd disc ceramic capacitor between lugs 3 (S-2) and ground lug 10 (NS) of tube socket V3.
- (X) C18. Connect a .005 μ fd disc ceramic capacitor between lugs 4 (S-1) and ground lug 10 (S-2) of tube socket V3.

- (X) C16. Connect a .005 μ fd disc ceramic capacitor between lugs 6 (NS) and ground lug 11 (S-1) of tube socket V3.
- (X) R13. Connect an 8.2 Ω (gray-red-gold) 1/2 watt resistor between lugs 6 (S-3) and ground lug 12 (S-3) of tube socket V3.

GENERAL CHASSIS ASSEMBLY

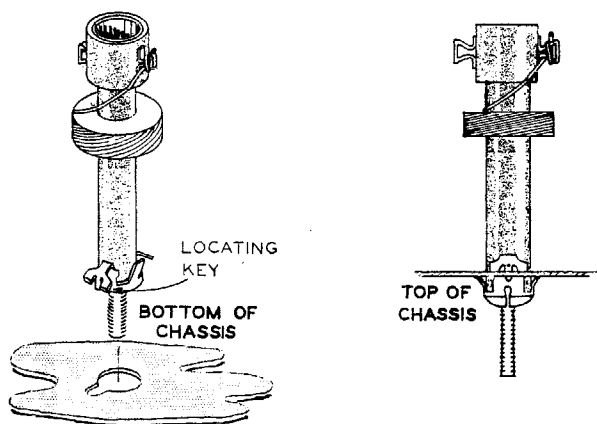

Detail 3C

Refer to Pictorial 3 for the following steps.

- (X) L1. Referring to Detail 3C, mount the driver coil (#40-79) at CA.
- (X) Connect a length of small bare wire from lug 1 of terminal strip M (S-3) to lug 1 of coil CA (S-1).
- (X) Connect a length of small bare wire from lug 6 of tube V1 (S-1) to lug 2 of coil CA (NS).
- (X) C6. Connect one untrimmed lead of a 47 μ fd silver mica capacitor to lug 2 of coil CA (S-2). Use sleeving. Leave the other lead free.

- (X) Referring to Detail 3D, mount standoff insulators in holes Y and Z, on top of the chassis at each end of the slot in the chassis. Use the hardware supplied with the standoffs but discard the flat washer and use a #6 lockwasher on the under-chassis screws.

- (X) Mount #6 solder lugs on each standoff above chassis as shown in Detail 3D.

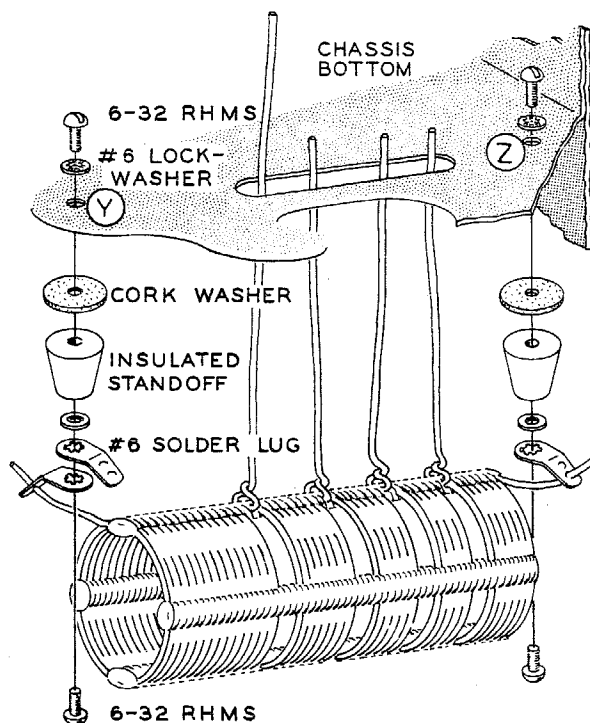

Detail 3D

- () L3. Mount the final amplifier tank coil by soldering each end to the top hole of the solder lug on each standoff. See Detail 3D. Refer to Pictorial 4 (fold-out from Page 27) for final positioning of this coil. Cut off any excess lead length.

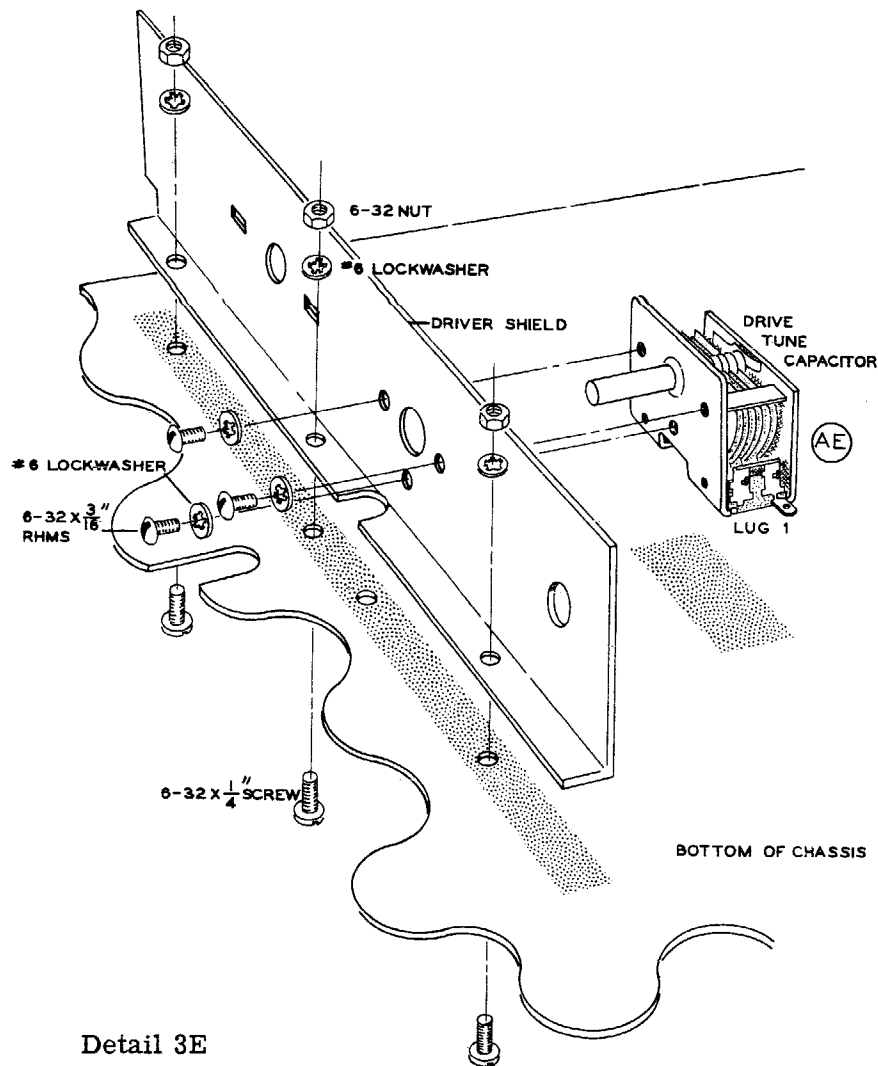

Detail 3E

- ⊗ C11. Referring to Detail 3E, mount the DRIVE TUNE capacitor (#26-64) to the driver shield. Use 6-32 x 3/16" RHMS and #6 lockwashers. Clip off lug 1 of AE.
- ⊗ Install the driver shield on the main chassis. Use #6 hardware. See Detail 3E and Pictorial 3.
- ⊗ Referring to Detail 3F, mount the CRYSTAL switch (#63-290) on the oscillator shield. Use a control lockwasher and control nut.
- ⊗ Install the oscillator shield on the main chassis. Use #6 hardware. See Detail 3F and Pictorial 3.
- ⊗ Slip a 1-1/4" length of sleeving over the free lead of the capacitor coming from lug 2 of coil CA. Place this lead through the small hole in the oscillator shield and connect it to lug 9 of tube socket V2 (S-2).

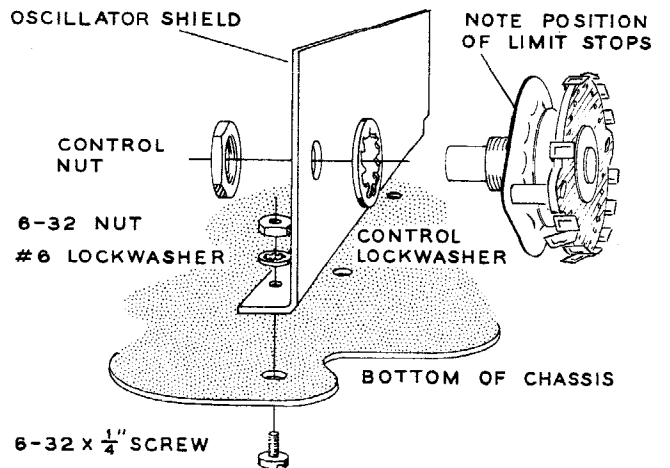

Detail 3F

⊗ Connect a 3" red hookup wire from lug 13 of switch AD (S-1) to lug 4 of accessory power socket BE (S-1).

⊗ Connect a 3" red hookup wire from lug 15 of switch AD (S-1) to lug 2 of electrolytic capacitor K(S-6).

() Referring to Detail 3G, mount crystal socket X4 on crystal socket bracket X. Use a 4-40 x 1/2" RHMS and a 4-40 nut. Do not over-tighten the screw as you may crack the socket.

⊗ Similarly, mount crystal sockets X1, X2, and X3.

⊗ Mount the crystal bracket subassembly at location X. Secure it with #6 hardware.

Connect #20 bare wires from CRYSTAL switch AD to the crystal sockets as follows:

<u>SWITCH LUGS</u>	<u>CRYSTAL SOCKET</u>
⊗ 12 (S-1)	lug 1 of X1 (S-1).
⊗ 14 (S-1)	lug 1 of X2 (S-1).
⊗ 16 (S-1)	lug 1 of X3 (S-1).
⊗ 18 (S-1)	lug 1 of X4 (S-1).
⊗ 1 (S-1)	lug 2 of X1 (S-1).
⊗ 3 (S-1)	lug 2 of X2 (S-1).
⊗ 5 (S-1)	lug 2 of X3 (S-1).
⊗ 7 (S-1)	lug 2 of X4 (S-1).

⊗ Connect a 3" length of #20 bare wire from lug 20 of CRYSTAL switch AD (S-1) to lug 1 of the VFO input jack BF (S-1). Use sleeving.

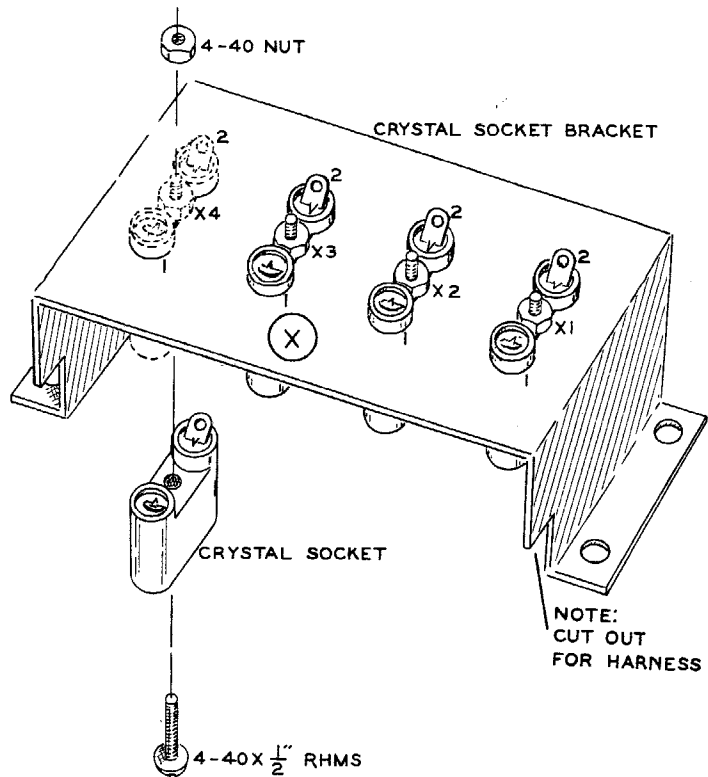

Detail 3G

⊗ C1. Cut both leads of a .001 μfd disc ceramic capacitor to 3/4". Connect this capacitor between lugs 11 (S-1) and 2 (NS) of CRYSTAL switch AD. Use sleeving on both leads.

⊗ Connect a 3" length of #20 bare wire from lug 22 of CRYSTAL switch AD (S-1) to lug 2 of tube socket V1 (S-1).

⊗ Connect a 3-1/2" length of #20 bare wire from lug 2 of CRYSTAL switch AD (S-2) to lug 8 of tube socket V1 (S-3).

Check all wiring around the crystal sockets and CRYSTAL switch for possible shorts.

TOP OF CHASSIS ASSEMBLY

Refer to Pictorial 4 (fold-out from Page 27) for the following steps.

- (X) Mount the meter switch (#60-15) on the front panel at AH. Use 6-32 x 1/4" screws. See Detail 4C for location.

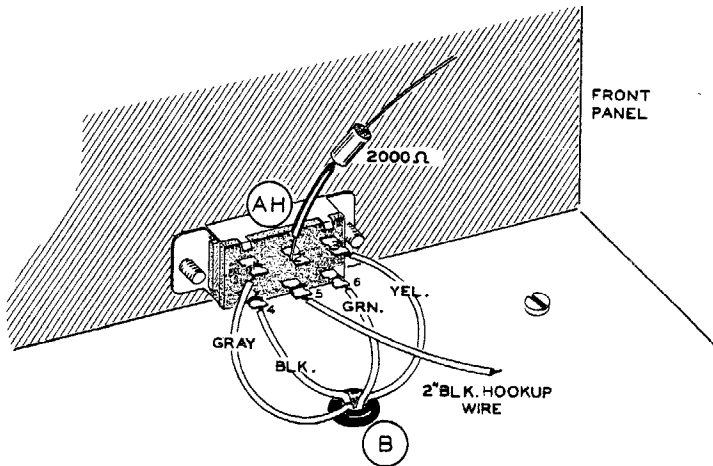

Detail 4A

Refer to Detail 4A for the following 6 steps.

- (X) Connect the green wire coming from grommet B to lug 6 of switch AH (S-1).
- (X) Connect the yellow wire coming from grommet B to lug 3 of switch AH (S-1).
- (X) Connect the black wire coming from grommet B to lug 4 of switch AH (S-1).
- (X) Connect the gray wire coming from grommet B to lug 1 of switch AH (S-1).
- (X) Connect one end of a 2" black hookup wire to lug 5 of switch AH (S-1). Leave the other end free.
- (X) R12. Cut one lead of a 2000 Ω (red-black-red) 1/2 watt resistor to 1". Connect this lead to lug 2 of switch AH (S-1). Use sleeving. Leave the other lead free.

NOTE: Make sure none of the switch lugs short to the meter bracket in the following instructions.

Refer to Detail 4B for the following steps.

- (X) Remove the meter from its box (remove the shorting wire) and secure it to the meter mounting bracket. Use the hardware supplied with the meter. Do not overtighten as you may crack the meter cover.
- (X) Install the meter escutcheon and the meter mounting bracket on the front panel. Use 4-40 x 3/8" RHMS and #4 lockwashers. Place the meter mounting spacers between the bracket and the front panel, then tighten.
- (X) Mount a pilot lamp socket on each side of the meter mounting bracket. Use 6-32 x 1/4" screws, #6 solder lugs and 6-32 nuts. Bend the lug nearest the front panel on each socket upward at a 90 degree angle.
- (X) Install a pilot lamp in each socket.

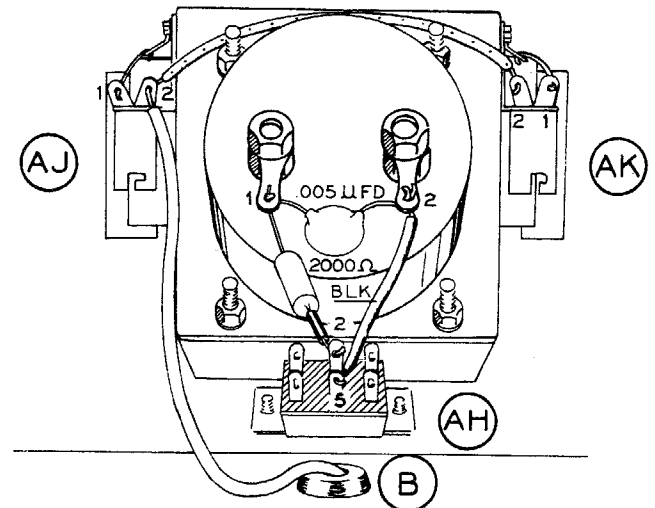

Detail 4C

Refer to Detail 4C for the following steps.

- (X) Connect a small bare wire from lug 1 of pilot light socket AJ (S-1) to the solder lug just above AJ (S-1).
- (X) Connect a small bare wire from lug 1 of pilot light socket AK (S-1) to the solder lug just above AK (S-1).

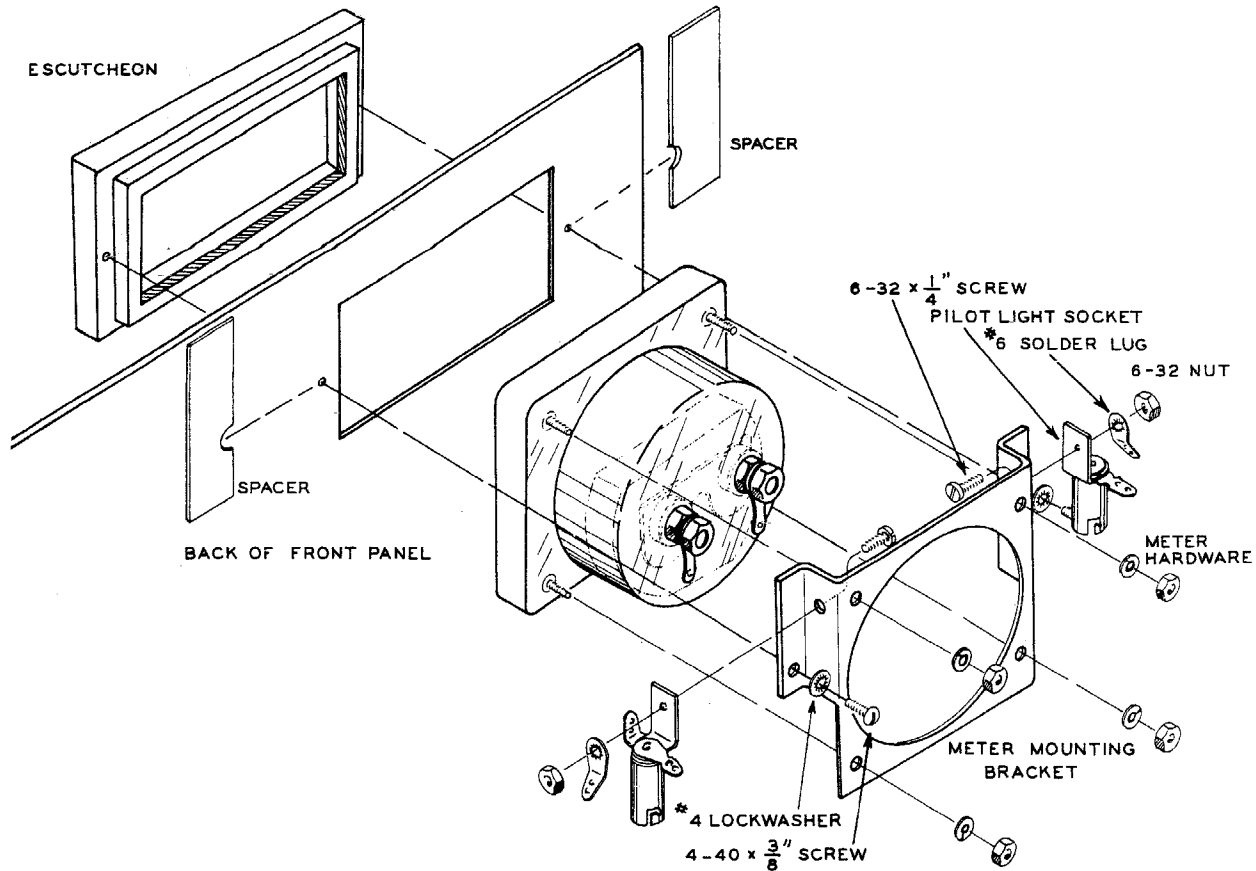

Detail 4B

- (X) Connect a 4-1/4" brown hookup wire from lug 2 of pilot light socket AJ (NS) to lug 2 of pilot light socket AK (S-1).
- (X) Connect the brown wire coming from grommet B to lug 2 of pilot light socket AJ (S-2).
- (X) C15. Connect a .005 μ fd disc ceramic capacitor between lugs 1 (NS) and 2 (NS) of the meter.
- (X) Connect the free lead of the 2000 Ω (red-black-red) resistor coming from lug 2 of switch AH to lug 1 of the meter (S-2). Remove any excess lead length.
- (X) Connect the free end of the black wire coming from lug 5 of switch AH to lug 2 of the meter (S-2).

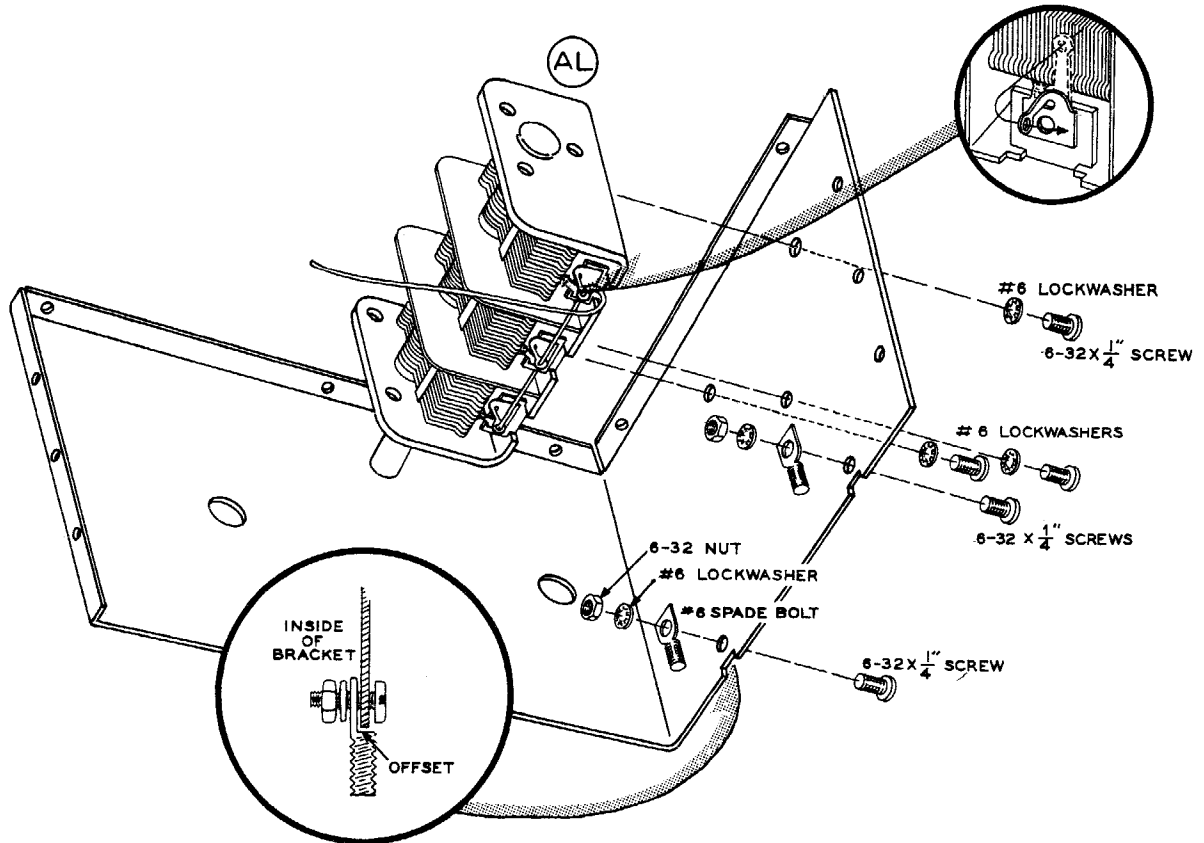

Detail 4D

Refer to Detail 4D for the following steps.

- (X) C24. Install loading capacitor AL on the side wall of the front half of the final amplifier shield. Use 6-32 x 1/4" screws and #6 lockwashers.
- (X) Bend the lugs on the bottom side of capacitor AL approximately 90 degrees to permit passage of a straight wire through all three.
- (X) Slip a 6" length of heavy bare wire through the lugs as shown in Detail 4D. Now, solder all three lugs. Make sure this wire does not touch the capacitor shield plates.
- (X) Mount two #6 spade bolts to the bottom of the front half of the final amplifier shield. Use #6 hardware. Be sure that the offset of each spade bolt is placed as shown.

This completes subassembly of the front half of the final amplifier shield.

Refer to Pictorial 4 for the following steps.

- (X) Fasten the front half of the final amplifier shield to the front panel with a bushing, control lockwasher, and control nut at AL. See Detail 4E. Do not tighten yet. The spade bolts should pass through the two corresponding holes in the chassis.
- (X) C22. Remove the hardware from final amplifier plate tuning capacitor (#26-31). Discard one of the two flat washers. Now mount the capacitor at AM. Use the remaining flat washer supplied with the capacitor and a control lockwasher on the capacitor bushing. Secure with a control flat washer and a control nut on the front panel. Tighten AL and AM.
- (X) Install #6 lockwashers and 6-32 nuts on the spade bolts under the chassis to secure the front half of the amplifier shield.
- (X) Referring to Detail 4E, fasten the flexible coupler to the shaft of variable capacitor

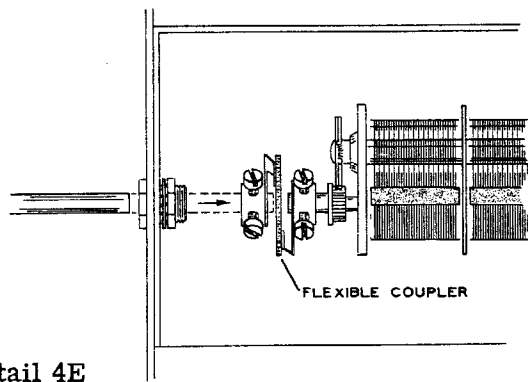

Detail 4E

AL. Now, insert the 1-3/4" shaft through the bushing at AL in the front panel and into the flexible coupler. About 5/8" should extend in front of the panel. Secure the coupler to the shaft.

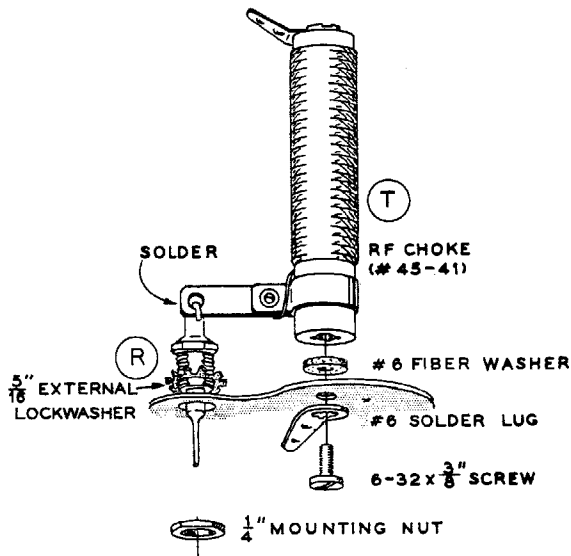

Detail 4F

- (X) C20. Referring to Detail 4F, mount feed-through capacitor R (#21-59). Use a 5/16" external lockwasher under the flange and secure with the special 1/4" nut supplied.
- (X) Mount the RF choke (#45-41) at T. Use a 6-32 x 3/8" screw and a #6 solder lug below the chassis. Place a #6 fiber washer over this screw above chassis. Do not overtighten as you may crack the coil form. Refer to Pictorial 6 for solder lug orientation.
- (X) Connect the bare wire extending from loading capacitor AL to the bottom hole of the solder lug on coil mounting standoff insulator Y (S-1).

- (X) Connect a 3" length of heavy bare wire from lug 2 of capacitor AM (S-1) to the bottom hole of the solder lug on coil mounting standoff insulator Z (S-1). Remove any excess lead length.
- (X) Connect a 5" length of heavy bare wire to the bottom hole of the unused solder lug on the standoff insulator Y (S-1). Dress this wire through the slot under the final tank coil. It will be connected later.
- (X) Solder the bottom lug of RF choke T to the wire extending from feed-through capacitor R. Cut off the excess lead.
- (X) C20. Connect a .001 μ fd 2000 volt mica capacitor from lug 1 of capacitor AM (NS) to the solder lug on top of choke T (NS). Position as shown.
- (X) Cut one lead of the parasitic choke (#45-19) to 3/4". Connect this lead to the ceramic tube cap (S-1).
- (X) Cut the other lead of the choke to 1/2" and connect it to the solder lug on top of choke T (S-2).
- (X) Cut a 3" length of large bare wire and wrap one end around lug 1 of variable capacitor AM (S-2). Place the other end of this wire through hole Q in the chassis. It will be connected later.
- (X) R20. Mount the 30 K Ω wire-wound resistor at location W. Use a 10-24 x 2-1/4" hexhead screw, #10 fiber shoulder washer, under the screw head, and secure with a 10-24 nut. Do not overtighten as you may crack the resistor.
- (X) Connect the black wire coming from grommet H to lug 3 of resistor W (S-1).
- (X) Connect the small red wire coming from grommet H to lug 2 of resistor W (S-1).
- (X) Connect the large red wire coming from grommet H to lug 1 of resistor W (S-1).
- (X) Locate the rear half of the final amplifier shield and mount four #6 spade bolts on it. (Mount each spade bolt on the inside of the shield with the offset facing the outside of the shield as in Detail 4D. Use #6 hardware.)

(X) Referring to Pictorials 4 and 6, mount the rear half of the final amplifier shield on top of the chassis and dual lug terminal strip S under the chassis. Use #6 lock-

washers and 6-32 nuts to secure the spade bolts, and use #6 sheet metal screws to secure both ends of the shield to the front shield.

LOW-PASS FILTER ASSEMBLY

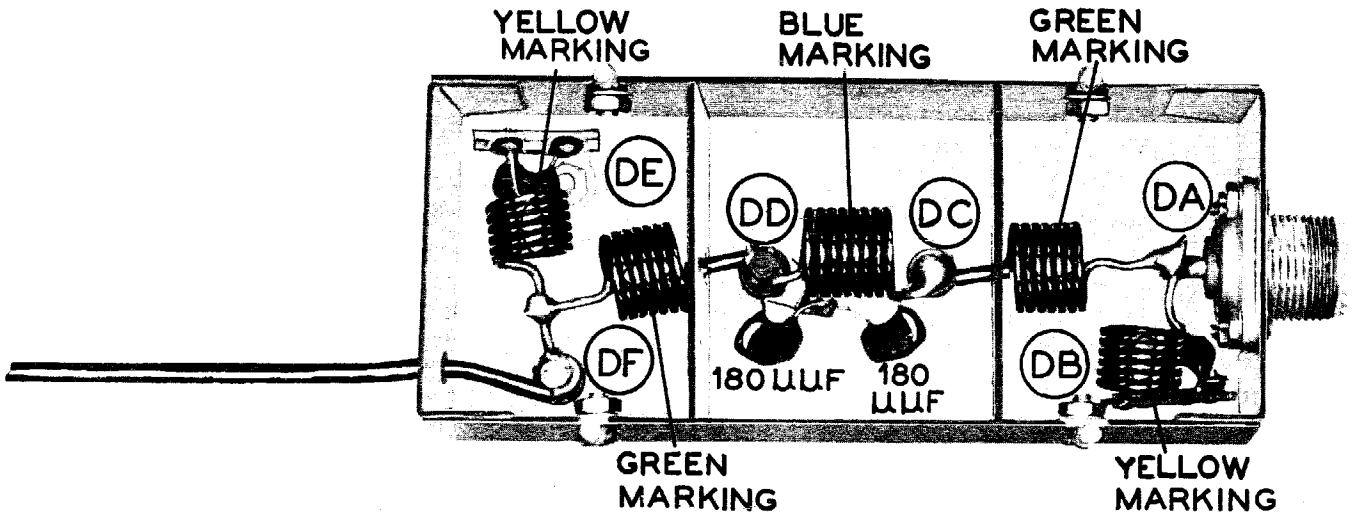

Pictorial 5

Refer to Pictorial 5 for the following steps.

(X) Referring to Detail 5A, mount antenna connector DA. Use 3-48 screws, #3 lockwashers, and 3-48 nuts.

(X) Mount a 2-lug terminal strip at DB. Use #6 hardware.

() Similarly, mount 2-lug terminal strip DE.

(X) Mount a small insulated standoff at DF. Use a #6 lockwasher and 6-32 nut.

(X) C28. Connect a 47 μ f silver mica capacitor between lugs 1 (S-1) and 2 (NS) of terminal strip DB.

Detail 5A

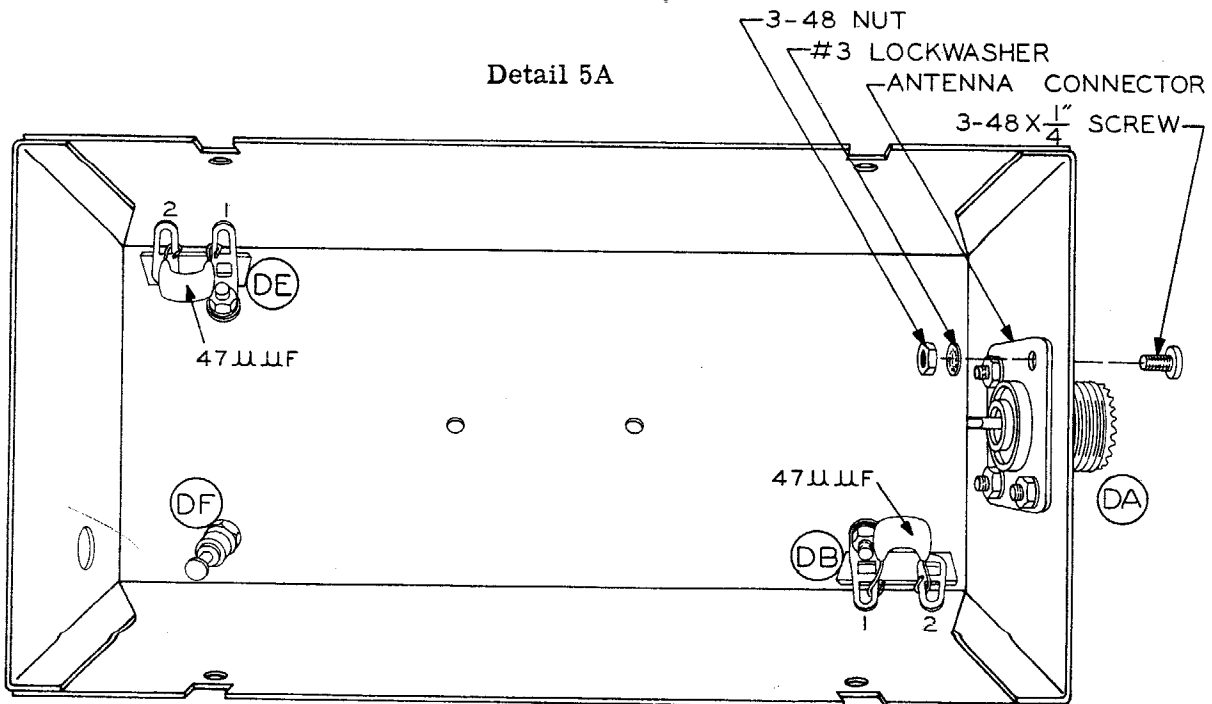

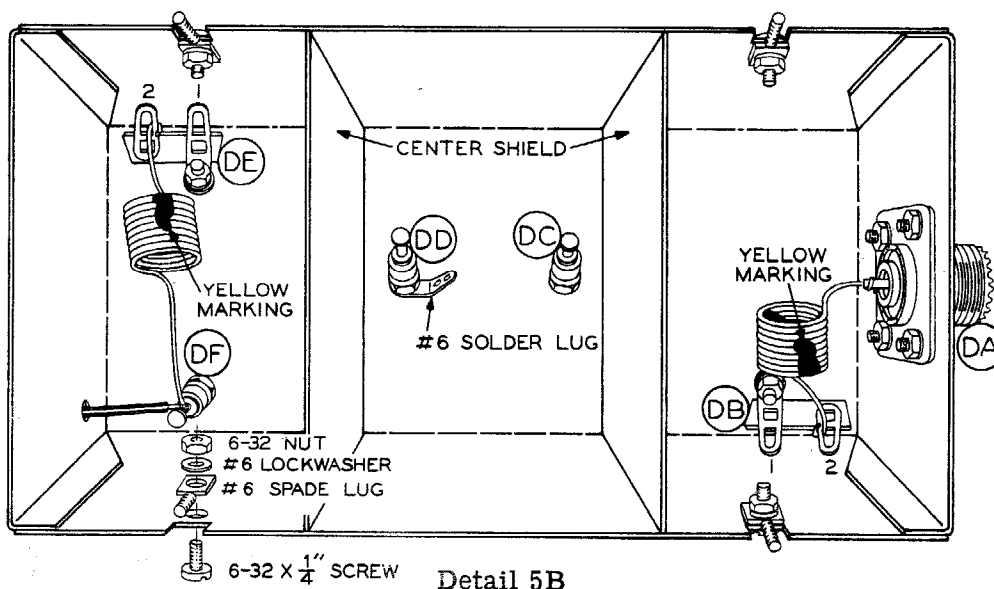

- (X) C25. Connect a 47 μf silver mica capacitor between lugs 1 (S-1) and 2 (NS) of terminal strip DE.
- (X) L8. Referring to Detail 5B, connect one of the low-pass filter coils (#40-347) with the yellow marking from the center lug of the antenna connector (NS) to lug 2 of terminal strip DB (S-2). Wrap the coil lead around the outside of the connector pin.
- (X) L4. Connect the remaining coil with the yellow marking (#40-347) from lug 2 of terminal strip DE (S-2) to standoff DF (NS).
- (X) Insert one end of a 3-1/2" length of heavy bare wire through the hole in low-pass filter housing and connect to standoff DF (S-2). Leave the other end free.
- (X) Mount the "U" shaped center shield in the low-pass filter with two insulated standoffs DC and DD. Use #6 lockwashers and 6-32 nuts. Be sure to mount a #6 solder lug under standoff DD.
- (X) C27. Connect a 180 μf silver mica capacitor from standoff DC (NS) to the solder lug secured by standoff DD (NS).
- (X) C26. Connect a 180 μf silver mica capacitor from standoff DD (NS) to the solder lug secured by DD (S-2).
- (X) L7. Connect one end of a coil with a green marking (#40-348) to the center pin of the antenna connector (S-2). Place the other end through the hole in the center shield and connect it to standoff DC (NS). Use sleeving on the lead to DC.
- (X) L5. Connect one end of the remaining coil with the green marking (#40-348) to the coil lead connected to DF (S-1). Place the other end of this coil through the hole in the center shield and connect it to standoff DD (NS). Use sleeving on the lead to DD.
- (X) L6. Connect the coil with the blue marking (#40-349) from standoff DC (S-3) to standoff DD (S-3).
- (X) Mount four #6 spade bolts on the low-pass filter chassis. They should be mounted on the inside of the chassis with the offset facing outward as shown in Detail 5B. Use #6 hardware.
- (X) Referring back to Pictorial 4, slip a 3-1/2" length of sleeving over the bare wire extending from the low-pass filter. Place the wire through the hole in the rear of the final amplifier shield and connect it to the top hole in the solder lug on the rear of standoff insulator Y (S-1). Remove any excess lead length. Check all connections.
- (X) Secure the low-pass filter in place. Use #6 lockwashers and 6-32 nuts on the spade bolts, under the chassis.

FINAL WIRING

Refer to Pictorial 6 for the following steps.

(X) Connect either lead of the red neon pilot lamp to lug 1 of terminal strip S (S-1). Use sleeving. Leave the other lead free.

(X) Connect the large red lead extending from the harness at breakout point K to .001 μ fd feed-through capacitor R (NS).

(X) R14. Connect a 470 K Ω (yellow-violet-yellow) 1/2 watt resistor from lug 2 of terminal strip S (S-1) to feed-through capacitor R (S-2). Remove excess feed-through capacitor lead length.

(X) Mount the key jack at AG using a thin control lockwasher on the jack bushing. Position as shown in Pictorial 6. Secure with a control flat washer, and control nut on the front panel.

(X) Connect a small bare wire between lugs 1 (S-1) and 2 (NS) of key jack AG.

(X) Connect the remaining lead of the red neon pilot lamp to lug 2 of key jack AG (S-2). Use sleeving.

(X) Connect the yellow harness wire coming from breakout point K to lug 3 of key jack AG (S-1).

(X) Mount the front section of the BAND switch (#63-244) at AF. Position the switch exactly as shown in Pictorial 6. Use a control lockwasher on the switch bushing, and a control flat washer and control nut on the front panel.

(X) C23. Connect a 68 μ fd 4kv disc ceramic capacitor from lug 5 of switch AF (S-1) to the solder lug at T (S-1).

(X) Connect the free end of the wire extending through the grommet Q to lug 6 of switch AF (S-1). Use sleeving. If this wire does not fit switch lug 6, the lug may be slightly enlarged or split at its center.

(X) Connect the final amplifier coil leads to switch AF as follows: (Use sleeving on each lead as listed.)

COIL LEAD	CONNECT TO LUG	SLEEVING LENGTH
-----------	----------------	-----------------

() 1	8 (S-1)	2-1/4"
() 2	9 (S-1)	2-1/4"
() 3	10 (S-1)	2-3/4"
() 4	11 (S-1)	3-1/2"
() 5	12 (S-1)	4-1/4"

Refer to Detail 6A for the following steps.

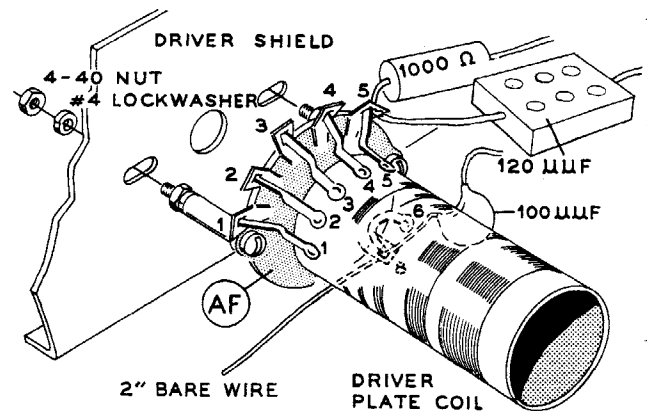

Detail 6A

(X) L2. Locate the driver plate coil (#40-337) and twist each lug approximately 90 degrees as shown.

NOTE: Examine the rear wafer of switch AF. All lugs on the rear wafer must be positioned as shown in Detail 6A.

(X) Connect lugs 1 through 5 of the driver plate coil to their corresponding lugs on the rear wafer of switch AF. Remove any excess coil lug length.

(X) Connect lug 6 of the driver plate coil to lug 8 of switch AF (NS). All lugs on the switch should be soldered except lugs 5 and 8.

(X) C13. Cut each lead of a 100 μ fd silver mica capacitor to 3/4". Connect one lead of this capacitor to lug 8 of switch AF (NS). Leave the other lead free.

- (X) Connect one end of a 2" small bare wire to lug 8 of switch AF (S-3). Leave the other end free.
- (X) C10. Cut each lead of a 120 $\mu\mu\text{f}$ molded mica capacitor to $3/4$ ". Connect one lead of this capacitor to lug 5 of switch AF (NS). Leave the other lead free.
- (X) R8. Cut each lead of a 1000 Ω (brown-black-red) 2 watt resistor to $1/2$ ". Connect one lead of the resistor to lug 5 of switch AF (NS). Leave the other lead free.

NOTE: Again examine the rear wafer, giving special attention to the rotor key mark opening. Refer to the following illustration. This opening must be in the same position as the one on the front wafer rotor. Note also, it is necessary to remove only one nut and lockwasher from each wafer stud.

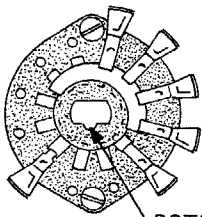

ROTOR KEY MARK
OPENING

- (X) Mount this rear wafer assembly of switch AF to the driver shield. Use the hardware supplied with the switch wafer and #4 lockwashers as shown in Detail 6A and position the wafer as shown in Pictorial 6.
- (X) Connect the free lead of the 100 $\mu\mu\text{f}$ silver mica capacitor coming from lug 8 of switch AF to lug 1 of terminal strip N (NS).
- (X) Connect the free end of the bare wire coming from lug 8 of switch AF to lug 2 of variable capacitor AE (NS). Use sleeving.
- (X) Connect a length of small bare wire from

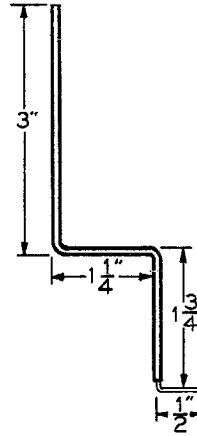

Detail 6B

lug 2 of variable capacitor AE (S-2) to lug 6 of tube socket V2 (S-1).

- (X) Connect the free lead of the 1000 Ω (brown-black-red) 2 watt resistor coming from lug 5 of switch AF to lug 3 of terminal strip N (S-3).
- (X) Connect the free lead of the 120 $\mu\mu\text{f}$ molded mica capacitor coming from lug 5 of switch AF to lug 4 of terminal strip N (S-3).
- (X) Connect a 1.1 mh choke (#45-4) between lugs 1 (S-3) and 5 (S-5) of terminal strip N.
- (X) Referring to Detail 6B, place a length of sleeving over a 6" heavy bare wire and bend it for use as the neutralizing stub.
- (X) Place the 1-3/4" end through grommet P from the top of the chassis.
- (X) Connect the below chassis end of this stub to lug 5 of the rear wafer of switch AF (S-4).
- (X) Place the 5" shaft through bushing AE and connect it to the variable capacitor shaft with the 1/4" coupler, using 6-32 screws.
- (X) Similarly, place the 8" shaft through bushing AD and connect it to the crystal switch shaft, using a 1/4" coupler and 6-32 screws.

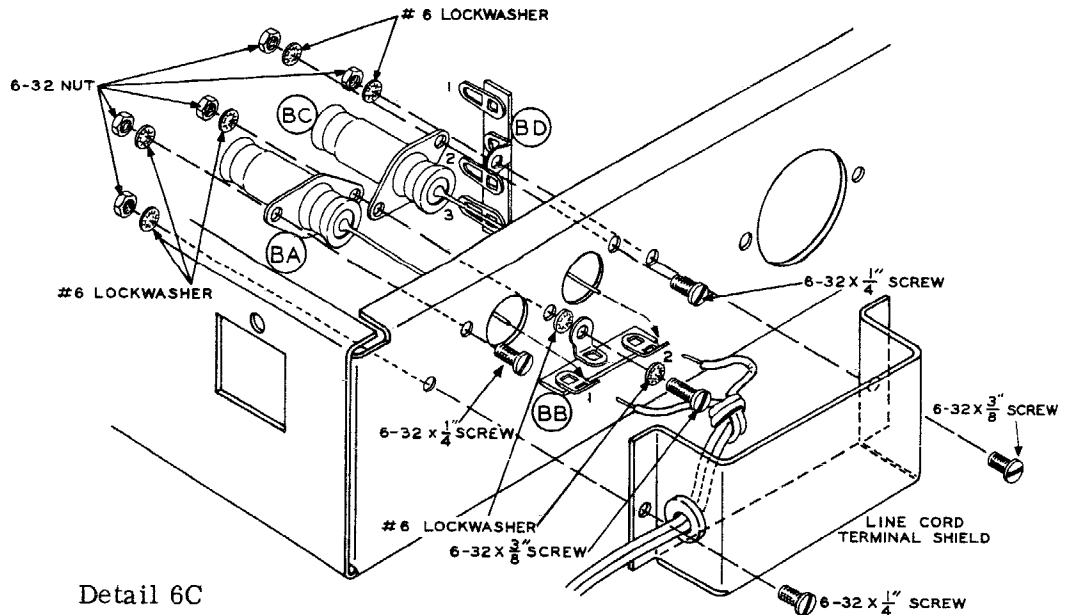

Detail 6C

Refer to Detail 6C for the following steps.

- (X) C40, C41. Mount feed-through capacitor BA, BC, and terminal strip BB. Use a 6-32 x 3/8" screw, three #6 lockwashers, and a 6-32 nut.
- (X) Secure the remaining corners of BA and BC with #6 hardware.
- (X) Bend lugs 1 and 2 of BB 90 degrees toward the capacitors. Connect the lead extending from capacitor BA to lug 1 of terminal strip BB (NS).
- (X) Connect the lead coming from capacitor BC to lug 2 of terminal strip BB (NS).

CAUTION: Be sure to remove excess capacitor leads and position them so there is clearance between the leads and capacitor body, as well as clearance between the terminal strip lugs and the capacitor body.

- (X) Place a 3/8" rubber grommet in the line cord terminal shield.
- () Place one end of the line cord through the grommet in the line cord terminal shield and tie an overhand knot 2" from the end for strain relief. Separate this end of the line cord back to the knot and cut 1/2" from either lead.
- () Remove 1/4" of insulation from the end of each lead and tin the end.

- (X) Connect the short lead to lug 1 of terminal strip BB (S-2).
- (X) Connect the other lead to lug 2 of terminal strip BB (S-2).
- (X) Mount the line cord terminal shield and 3-lug terminal strip BD. Use a 6-32 x 3/8" screw, #6 lockwasher, and 6-32 nut for the double mounting. Use #6 hardware for the other mounting hole.
- (X) Connect the longest black transformer lead to lug 3 of terminal strip BD (NS).
- (X) Connect the remaining black transformer lead to lug 1 of terminal strip BD (NS).
- () Connect the longest black harness lead from breakout point E to lug 1 of terminal strip BD (S-2).
- (X) Connect the other black harness lead from breakout point E to lug 2 of terminal strip BD (NS).
- (X) Connect the remaining lead of capacitor BA to lug 3 of terminal strip BD (NS). Use sleeving.
- (X) Connect a 3" white wire from lug 3 of terminal strip BD (S-3) to lug 6 of socket BE (S-1).
- (X) Connect the remaining lead of capacitor BC to lug 2 of terminal strip BD (S2). Use sleeving.

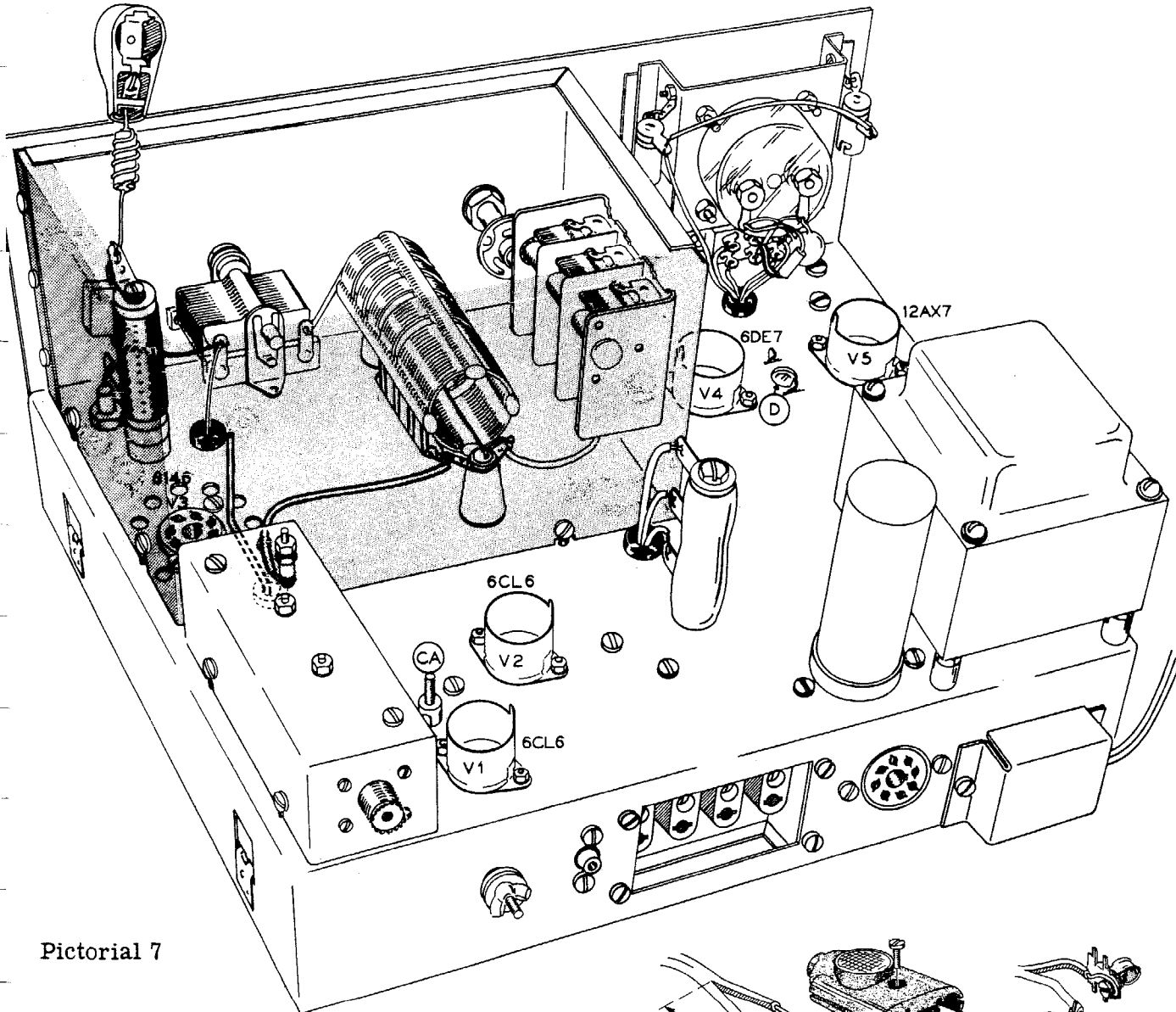

Pictorial 7

Refer to Detail 7A for the following step.

- (X) Install the fuse plug on the free end of the line cord. Open the plug to expose the screw terminals. Split the line cord approximately 1" back from the end and separate the leads. Strip the lead ends 1/2" and tin. Position the cord in the bell of the plug, run the leads along the separate channels provided and connect the wires to the screw terminals with a hook, in the same direction as the screw rotation. Reassemble the plug and install the two 3 ampere fuses.

This completes wiring of the HEATHKIT DX-60 Transmitter.

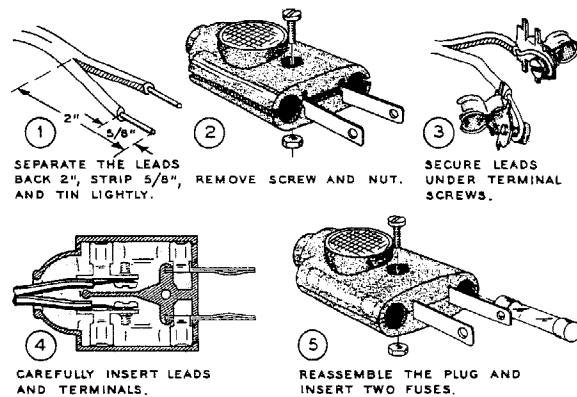

Detail 7A

- (X) Referring to Pictorial 7, install the tubes in the sockets. Place the short tube shield on V5 and the remaining shields on V1, V2, and V4. Place the ceramic plate cap on V3.

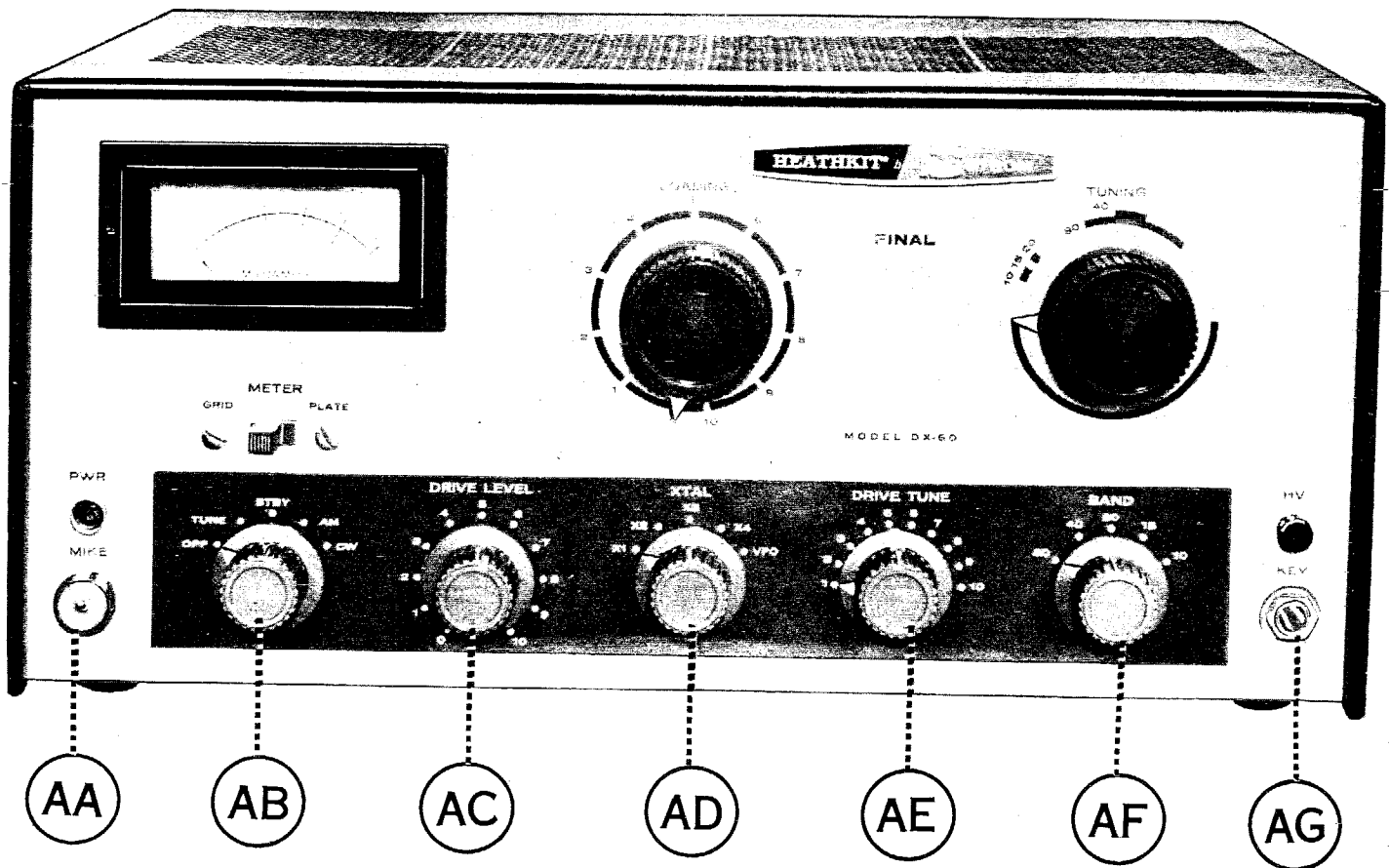

Pictorial 8

Refer to Pictorial 8 for the following steps.

- (X) Place all controls in their maximum counterclockwise position. The plates of the final tuning capacitor should be fully meshed.
- (X) Mount the skirted knobs on controls AB, AC, AD, AE, and AF, with the pointers

indicating the start of rotation. Now, place one of the large knobs on the FINAL LOADING control with the pointer at O. Similarly, install a large knob on the FINAL TUNING control with the pointer at the 3 o'clock position.

INITIAL TEST AND ADJUSTMENT

Before applying power to the DX-60, carefully examine your wiring for unintentional short circuits. Make sure that all wire clippings and solder splashes are removed from the wiring.

- (X) If an ohmmeter is available, measure the resistance from lug 2 of terminal strip G (+) to ground. The ohmmeter should "kick" down scale and then gradually rise to about 30 K Ω .
- (X) Referring to Detail 9A, construct a dummy load. Use a 75 watt light bulb.

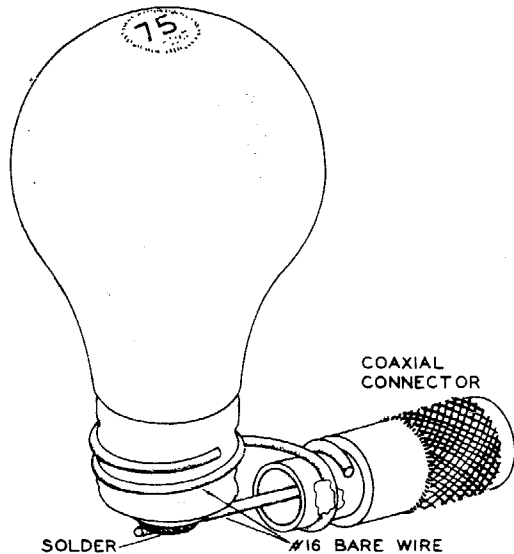

Detail 9A

- (X) Attach the dummy load to the antenna connector on the low-pass filter.
- (X) Select a crystal, preferably an 80 meter crystal, and install it in crystal socket X1.
- (X) Place all controls except FINAL TUNING in their maximum counterclockwise position. (The FINAL TUNING control should be set to the panel marking for the band being used, in this case the 80 meter position.)

WARNING: BEFORE APPLYING POWER TO THE TRANSMITTER, IT SHOULD BE NOTED THAT LETHAL VOLTAGES ARE PRESENT BOTH ABOVE AND BELOW THE CHASSIS. CARE SHOULD BE EXERCISED NOT TO TOUCH ANY HIGH VOLTAGE POINTS WITH YOUR HANDS. WELL INSULATED TOOLS SHOULD BE USED FOR ANY ADJUSTMENTS BEHIND THE FRONT PANEL. ALWAYS REMOVE THE LINE CORD PLUG WHEN SERVICING THIS TRANSMITTER.

WARNING: BE SURE ALL CONTROLS ARE SET AS LISTED PREVIOUSLY.

- (X) Plug the line cord into a 117 volt, 60 cycle AC outlet.
- (X) Turn the Function switch to the STANDBY (STBY) position. The meter pilot lamp, the clear neon lamp, and all tube filaments should light. If any overheating, arcing, or smoke is noticed, immediately unplug the transmitter from the AC outlet and refer to the In Case Of Difficulty section on Page 38.
- (X) If everything appears normal, make sure that the CRYSTAL switch is in the X1 position, and that the METER switch is in the GRID position. Turn the Function switch to the TUNE position.

CAUTION: This transmitter produces more than sufficient grid drive on all bands. Be sure to reduce grid drive with the DRIVE LEVEL control when it exceeds 2.5 ma to prevent tube damage.

- (X) Advance the DRIVE LEVEL control to 1. Now, adjust the DRIVE TUNE control for maximum reading on the meter. (If the meter pointer goes off scale, readjust the DRIVE LEVEL control setting.) After peaking the DRIVE TUNE control, set the DRIVE LEVEL control for a reading of 2.5 milliamperes.

- Return the Function switch to the STANDBY position.

WARNING: If you do not obtain a grid drive reading do not attempt to continue, since the final amplifier may be damaged. If at any point in the following steps the indicated results are not obtained, return the Function switch to STANDBY (STBY), and refer to the In Case Of Difficulty section on Page 38.

- Place the METER switch in the PLATE position.

- Turn the Function switch to the AM position and immediately adjust the FINAL TUNING control for a dip, or minimum plate current reading on the meter.

- Turn the Function Switch to CW.

- Now, advance the FINAL LOADING control approximately 1/4 turn. Readjust the FINAL TUNING control for a dip. Notice that the meter reading has increased slightly and possibly the dummy load will begin to glow.

- Alternately advance the FINAL LOADING control in 1/4 turn steps, and each time readjust the FINAL TUNING control for a dip in the meter reading. Repeat this procedure until the meter reading, when at the minimum point of the dip, reaches 150 ma.

- Place the METER switch in the GRID position and adjust the DRIVE LEVEL control for 2.5 ma. Return the METER switch to the PLATE position.

- Place the Function switch in the STANDBY position.

- Attach a crystal or other high impedance microphone to the MIKE jack. Turn the Function switch to the AM position and speak into the microphone. While speaking in a normal tone adjust the audio gain control (D), see Pictorial 7, until the meter peaks at the point to which the transmitter was loaded on CW. Now, return the Function switch to STANDBY.

- Repeat the preceding steps with the BAND switch in the 40, 20, 15, and 10 meter positions. We suggest that you use 40 meter crystals for these bands. MIKE gain need not be readjusted once set.

- Set the BAND switch to 10 meters, the METER switch to the GRID position, and the XTAL switch to the X2 position, whose crystal socket should contain a 40 meter crystal that will multiply up to the center of the 10 meter band. Refer to Page 36 for crystal information.

- Place the Function switch in the TUNE position and adjust DRIVE TUNE for maximum drive, setting DRIVE LEVEL for normal 2.5 ma grid drive. Now, adjust 10-meter driver coil CA for maximum indication on the meter. Reduce the drive if excessive. See Pictorial 7.

- Turn the transmitter off and remove the line cord plug from the AC outlet.

NEUTRALIZATION ADJUSTMENT

To assure stable amplifier operation, it is generally necessary to use a neutralizing circuit. In the DX-60, this is accomplished by carefully adjusting the neutralizing stub in the amplifier compartment until an RF indicator, coupled to the final plate tank circuit (with high voltage disconnected!), reads minimum for resonant settings of both the DRIVE and FINAL tuning controls.

- Place the transmitter on end and disconnect the heavy red wire from feed-through capacitor R. (This removes B+ from the plate of the final amplifier.)

- Plug the line cord into 117 V AC outlet.

- Select a crystal frequency near the center of the 10 meter band.

- Place the Function switch in the TUNE position and the METER switch in the GRID position.

- Adjust the DRIVE LEVEL and DRIVE TUNE control for a normal operating level.

- Loosely couple a grid dip meter to the 10-meter portion of the final tank coil, or connect the high impedance probe of a VTVM between the coaxial output connector and ground. Use a low AC range.

- (X) Set the FINAL LOADING control to zero and set the FINAL TUNING control for a maximum reading on the RF indicator.
- (X) Now, adjust the physical position of the neutralizing stub for a minimum reading on the RF indicator. Readjust the FINAL TUNING control for peak indication again, and also reposition the neutralization stub for minimum RF indication. When the final amplifier has been neutralized the FINAL TUNING capacitor can be rotated with very little variation in the RF indicator reading.

If an RF indicating device is not available a preset adjustment may be made as follows:

- () With the line cord unplugged from the AC outlet, adjust the neutralizing stub so that it is approximately 1/4" from the final amplifier tube.
- () Connect the heavy red wire back to feed-through capacitor R (S-2).

If it becomes necessary to replace the final amplifier tube, be sure to recheck neutralization. If necessary to reneutralize, follow the neutralization procedure just completed.

FINAL ASSEMBLY

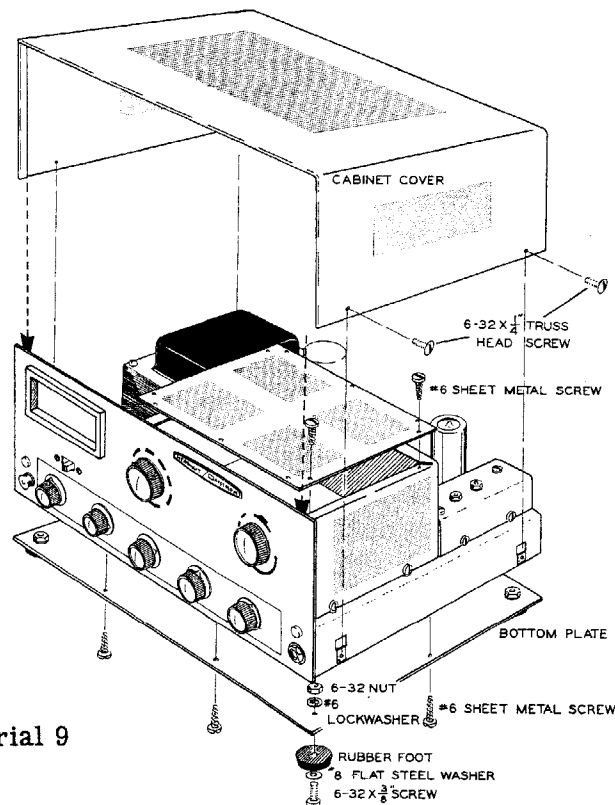

Pictorial 9

Refer to Pictorial 9 for the following steps.

- (X) Mount the final amplifier top shield using #6 sheet metal screws.
- (X) Install four rubber feet on the bottom plate as shown in Pictorial 9. Use 6-32 x 3/8" screws, #6 flat steel washers, #6 lockwashers, and 6-32 nuts.

- (X) Mount the bottom plate to the chassis with #6 sheet metal screws.

- () Place the cabinet cover over the chassis and secure it on each side with two 6-32 x 1/4" truss-head screws.

Before putting the DX-60 on the air, be sure to read the information in the Operation section which follows.

OPERATION

NOTE: It should be noted that an Amateur Radio Operator and Station License is required to place this transmitter on the air. Information regarding licensing and amateur frequency allocations may be obtained from publications of the Federal Communications Commission or the American Radio Relay League.

ANTENNAS

The pi network output circuit of the DX-60 will match pure resistive loads of 50 to 75 Ω .

The simplest type of antenna that falls into this impedance range is the "dipole," constructed so that its length is 1/2 wave at the frequency of operation. The 50 to 75 Ω impedance range also covers other "home brew" antennas such as beams, verticals, and trapped antennas.

Much has been published on this subject of antennas and excellent articles can be found in the ARRL Handbook, Radio Handbook, and in most issues of CQ and QST magazines.

OPERATION WITH CRYSTALS

The DX-60 may be satisfactorily operated using the following crystals:

Band	Fundamental Crystals
80 meters	160 or 80 meter crystals
40 meters	80 or 40 meter crystals
20 meters	80 or 40 meter crystals
15 meters	40 meter crystals
10 meters	40 meter crystals

Pin spacing .486" Pin size .093 dia.

NOVICE operation imposes restrictions on operating frequencies as follows:

Band	Frequency
80 Meters	3700-3750 kc
40 Meters	7150-7200 kc
15 Meters	21,100-21,250 kc

NOVICE power input is limited to 75 watts. In the operating instructions to follow, the final amplifier is loaded to 120 ma for novice operation, which is within the present Novice power limitation.

CAUTION: Be sure to check the latest FCC regulations on frequency allocations and power input requirements. When ordering crystals be sure to stay well within amateur band edge limits and power input to avoid violations.

OPERATION WITH VFO

The accessory socket on the rear apron of the DX-60 makes available 6.3 V AC at 4 amperes, 300 V DC at 50 ma, and about -65 V DC key up for grid-block keying of an external VFO.

Grid-block keying of the VFO used is recommended to be compatible with the keying system used in your DX-60. The HEATHKIT HG-10 VFO is designed to match the DX-60. To use the HG-10 VFO, just plug its power cable into the accessory socket of the DX-60 and plug the RF cable into both units. If the older HEATHKIT VFO, Model VF-1, is used, the following partial schematic shows the necessary modifications for this conversion. One 2-lug terminal strip is included with the DX-60 for VFO modification if needed.

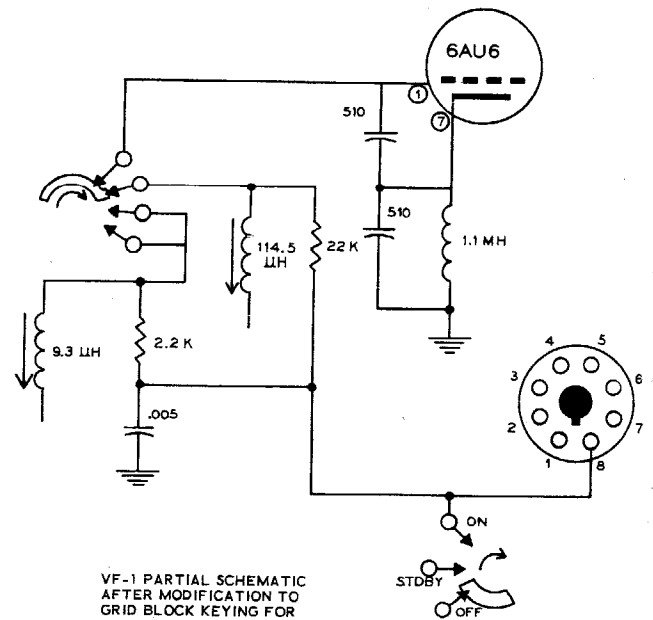

VF-1 PARTIAL SCHEMATIC AFTER MODIFICATION TO GRID BLOCK KEYING FOR USE WITH DX-60

IF A KEY IS USED IT MUST BE PLUGGED INTO THE DX-60. NORMAL CW OPERATION IS OBTAINED WITH THE VF-1 IN STDBY. TO SPOT, TURN THE DX-60 FUNCTION SWITCH TO TUNE AND KEY. TURNING THE VF-1 TO "ON" DUPLICATES KEYING OR REMOVAL OF THE KEY FROM THE DX-60 KEY JACK. THIS MUST BE DONE FOR AM OPERATION.

ACCESSORY SOCKET

See the Schematic and screened transmitter rear apron for all filament, bias, relay, and B+ accessory connections.

OPERATING INSTRUCTIONS FOR CW OR AM

1. Plug the line cord into the AC outlet and check to be sure the antenna is connected.
2. Turn the Function Switch to STDBY.
3. Set the DRIVE LEVEL to about 2-1/2.
4. Select desired XTAL or VFO mode.
5. Select the desired BAND.
6. Set the FINAL TUNING capacitor in the desired band area as indicated on the front panel.
7. Set the FINAL LOADING control fully counterclockwise.
8. Set the METER switch to GRID position.
9. Turn the Function Switch to TUNE.
10. Rotate the DRIVE TUNE control for maximum grid meter reading.
11. Set the DRIVE LEVEL to 2.5 ma of grid current.
12. Change METER switch to PLATE position.
13. Turn the Function switch to AM position.
14. Rotate the FINAL TUNING control to obtain a minimum plate current meter reading.
15. Turn the Function switch to CW.
16. While maintaining minimum plate current by tuning the FINAL tuning control, increase the

FINAL LOADING control in small steps in a clockwise direction until the transmitter is loaded to - A. 120 ma for Novice operation or B. 150 ma for regular operation.

17. Return the METER switch to GRID position.
18. Check and reset the grid drive to 2.5 ma if needed.
19. Return the Function switch to STDBY.
20. Return the METER switch to PLATE position.

- FOR CW =
1. Insert key plug in key jack.
 2. When ready to transmit turn the Function Switch to CW and proceed. (NOTE: In the key-up position on CW, the Final plate current will be approximately 20 ma.)

- FOR AM =
1. Remove key plug from key jack if in place.
 2. Connect microphone.
 3. When ready to transmit, turn the Function Switch to AM and proceed.

OPERATING REMINDERS

- A. If frequency changes of more than a few kilocycles occur, the final amplifier and driver stages may require retuning.
- B. Operation of the transmitter without a crystal, a proper antenna, or dummy load will result in component failure.
- C. Operation of the transmitter with the final amplifier not tuned to resonance (minimum plate current) may ruin the final amplifier tube.
- D. Use caution and observe rules of safety in making all voltage and current measurements.
- E. Do not cover cabinet ventilation holes.

IN CASE OF DIFFICULTY

1. Recheck the wiring. Trace each lead in colored pencil on the Pictorial as it is checked. It is frequently helpful to have a friend check your work. Someone who is not familiar with the unit may notice something consistently overlooked by the constructor.
2. It is interesting to note that about 90% of the kits that are returned for repair, malfunction due to poor connections and soldering. Therefore, many troubles can be eliminated by reheating all connections to make sure that they are soldered as illustrated in the Figures found in the **SOLDERING TECHNIQUES** section of this manual.
3. Check to be sure that all tubes are in their proper locations. Make sure that all tubes light up properly.
4. Check the tubes with a tube tester or by substitution of tubes of the same types and known to be good.
5. Check the values of the component parts. Be sure that the proper part has been wired into the circuit, as shown in the pictorial diagrams and as called out in the wiring instructions.
6. Check for bits of solder, wire ends or other foreign matter which may be lodged in the wiring beneath the chassis.
7. If, after careful checks, the trouble is still not located and a voltmeter is available, check voltage readings against those found on the Schematic Diagram. NOTE: All voltage readings were taken with a HEATH-KIT Vacuum Tube Voltmeter. Voltages may vary 10% due to line voltage variations.
8. A review of the Circuit Description and Block Diagrams will prove helpful in indicating where to look for trouble.

TROUBLESHOOTING

OSCILLATOR

To determine if the oscillator stage is operating, measure the voltage at pin 2 or pin 9. Key-down voltage should be -18 V DC; with the key up, the voltage should be -85 V DC. Also check other voltages around tube socket V1, and check wiring of the crystal sockets and CRYSTAL switch.

DRIVER

Driver voltage can be checked at pin 2 or pin 9 of V2. Key-down voltage should be -95 V DC, key-up voltage -85 V DC. If the oscillator bias was normal, but there is no driver bias with the key down, check the 40 meter coil. Try re-peaking this coil. If there is no bias on the driver stage with the key up or down, check the 1 mh RF choke, R5, and C1. Check all voltages around V2.

FINAL AMPLIFIER

With the driver stage tuned for 2.5 ma drive, measure key-up and key-down voltage on V3.

If no operating bias is measured, check the rear wafer of the BAND switch, the 1.1 mh RFC, R10, R11, and R15. Check all voltages on V3.

If bias is normal (about -65 volts) but there is no dip in final plate current, check the front wafer of the BAND switch, and check for shorted plates in FINAL LOADING or TUNING capacitors. Remove the low-pass filter from the circuit by disconnecting it from the final amplifier tank coil, and check for a final plate current dip. If a dip is now obtainable, check construction of the low-pass filter for possible wiring errors or shorts.

AUDIO SECTION

Carefully check the voltages on V4 and V5. Try a substitute microphone to further isolate the problem. Be sure that the Audio Gain control is set properly. An audio oscillator and oscilloscope may be used for checking this stage.

POWER SUPPLY

Voltage checks at various points in the power supply will localize the problem. If B+ voltage is low, check R18, R19, the silicon diodes, C36, C37, and C38. If the -135 VDC bias is not present, check C39 and the bias supply silicon diode. If the silicon diode is installed in reverse, +135 VDC would appear across C39.

SERVICE INFORMATION

SERVICE

If, after applying the information contained in this manual and your best efforts, you are still unable to obtain proper performance, it is suggested that you take advantage of the technical facilities which the Heath Company makes available to its customers.

The Technical Consultation Department is maintained for your benefit. This service is available to you at no charge. Its primary purpose is to provide assistance for those who encounter difficulty in the construction, operation or maintenance of HEATHKIT equipment. It is not intended, and is not equipped to function as a general source of technical information involving kit modifications nor anything other than the normal and specified performance of HEATHKIT equipment.

Although the Technical Consultants are familiar with all details of this kit, the effectiveness of their advice will depend entirely upon the amount and the accuracy of the information furnished by you. In a sense, YOU MUST QUALIFY for GOOD technical advice by helping the consultants to help you. Please use this outline:

1. Before writing, fully investigate each of the hints and suggestions listed in this manual under "IN CASE OF DIFFICULTY." Possibly it will not be necessary to write.
2. When writing, clearly describe the nature of the trouble and mention all associated equipment. Specifically report operating procedures, switch positions, connections

to other units, and anything else that might help to isolate the cause of trouble.

3. Report fully on the results obtained when testing the unit initially and when following the suggestions under In Case Of Difficulty. Be as specific as possible and include voltage readings if test equipment is available.
4. Identify the kit model number and date of purchase, if available. Also mention the date of the kit assembly manual. (Date at bottom of Page 1.)
5. Print or type your name and address, preferably in two places on the letter.

With the preceding information, the consultant will know exactly what kit you have, what you would like it to do for you and the difficulty you wish to correct. The date of purchase tells him whether or not engineering changes have been made since it was shipped to you. He will know what you have done in an effort to locate the cause of trouble and, thereby, avoid repetitious suggestions. In short, he will devote full time to the problem at hand, and through his familiarity with the kit, plus your accurate report, he will be able to give you a complete and helpful answer. If replacement parts are required, they will be shipped to you, subject to the terms of the Warranty.

The Factory Service facilities are also available to you, in case you are not familiar enough with electronics to provide our consultants with sufficient information on which to base a diagnosis of your difficulty, or in the event that you pre-

fer to have the difficulty corrected in this manner. You may return the completed instrument to the Heath Company for inspection and necessary repairs and adjustments. You will be charged a minimal service fee, plus the price of any additional parts or material required. However, if the completed kit is returned within the Warranty period, parts charges will be governed by the terms of the Warranty. State the date of purchase, if possible.

Local Service by Authorized HEATHKIT Service Centers is also available in some areas and often will be your fastest, most efficient method of obtaining service for your HEATHKIT equipment. Although you may find charges for local service somewhat higher than for factory service, the amount of increase is usually offset by the transportation charge you would pay if you elected to return your kit to the Heath Company.

HEATHKIT Service Centers will honor the regular 90 day HEATHKIT Parts Warranty on all kits, whether purchased through a dealer or directly from Heath Company; however, it will be necessary that you verify the purchase date of your kit.

Under the conditions specified in the Warranty, replacement parts are supplied without charge; however, if the Service Center assists you in locating a defective part (or parts) in your kit, or installs a replacement part for you, you may be charged for this service.

HEATHKIT equipment purchased locally and returned to Heath Company for service must be accompanied by your copy of the dated sales receipt from your authorized HEATHKIT dealer in order to be eligible for parts replacement under the terms of the Warranty.

THIS SERVICE POLICY APPLIES ONLY TO COMPLETED EQUIPMENT CONSTRUCTED IN ACCORDANCE WITH THE INSTRUCTIONS AS STATED IN THE MANUAL. Equipment that has been modified in design will not be accepted for repair. If there is evidence of acid core solder or paste fluxes, the equipment will be returned NOT repaired.

For information regarding modification of HEATHKIT equipment for special applica-

tions, it is suggested that you refer to any one or more of the many publications that are available on all phases of electronics. They can be obtained at or through your local library, as well as at most electronic equipment stores. Although the Heath Company sincerely welcomes all comments and suggestions, it would be impossible to design, test, evaluate and assume responsibility for proposed circuit changes for special purposes. Therefore, such modifications must be made at the discretion of the kit builder, using information available from sources other than the Heath Company.

REPLACEMENTS

Material supplied with HEATHKIT products has been carefully selected to meet design requirements and ordinarily will fulfill its function without difficulty. Occasionally improper instrument operation can be traced to a faulty component. Should inspection reveal the necessity for replacement, write to the Heath Company and supply all of the following information.

- A. Thoroughly identify the part in question by using the part number and description found in the manual Parts List.
- B. Identify the type and model number of kit in which it is used.
- C. Mention date of purchase.
- D. Describe the nature of defect or reason for requesting replacement.

The Heath Company will promptly supply the necessary replacement. **PLEASE DO NOT RETURN THE ORIGINAL COMPONENT UNTIL SPECIFICALLY REQUESTED TO DO SO.** Do not dismantle the component in question as this will void the guarantee. This replacement policy does not cover the free replacement of parts that may have been broken or damaged through carelessness on the part of the kit builder.

SHIPPING INSTRUCTIONS

In the event that your instrument must be returned for service, these instructions should be carefully followed.

RETURN WITH TOP COVER AND ALL TUBES INSTALLED. ATTACH A TAG TO THE EQUIP-

MENT BEARING YOUR NAME, COMPLETE ADDRESS, DATE OF PURCHASE, AND A BRIEF DESCRIPTION OF THE DIFFICULTY ENCOUNTERED. Wrap the equipment in heavy paper, exercising care to prevent damage. Place the wrapped equipment in a stout carton of such size that at least three inches of shredded paper, excelsior, or other resilient packing material can be placed between all sides of the wrapped equipment and the carton. Close and seal the carton with gummed paper tape, or alternately, tie securely with stout cord. Clearly print the address on the carton as follows:

To: HEATH COMPANY
Benton Harbor, Michigan

Include your name and return address on the outside of the carton. Preferably affix one or more "Fragile" or "Handle With Care" labels to the carton, or otherwise so mark with a crayon of bright color. Ship by insured parcel post or prepaid express; note that a carrier cannot be held responsible for damage in transit if, in HIS OPINION, the article is inadequately packed for shipment.

WARRANTY

Heath Company warrants that for a period of three months from the date of shipment, all Heathkit parts shall be free of defects in materials and workmanship under normal use and service and that in fulfillment of any breach of such warranty, Heath Company shall replace such defective parts upon the return of the same to its factory. The foregoing warranty shall apply only to the original buyer, and is and shall be in lieu of all other warranties, whether express or implied and of all other obligations or liabilities on the part of Heath Company and in no event shall Heath Company be liable for any anticipated profits, consequential damages, loss of time or other losses incurred by the buyer in connection with the purchase, assembly or operation of Heathkits or components thereof. No replacement shall be made of parts damaged by the buyer in the course of handling or assembling Heathkit equipment.

NOTE: The foregoing warranty is completely void and we will not replace, repair or service instruments or parts thereof in which acid core solder or paste fluxes have been used.

HEATH COMPANY

CUSTOMER SERVICE

REPLACEMENT PARTS

If you need a replacement part, please fill in the Parts Order Form that is furnished and mail it to the Heath Company. Or, if you write a letter, include the:

- Part number and description as shown in the Parts List.
- Model number and Series number from the blue and white label.
- Date of purchase.
- Nature of the defect.

Please do not return parts to the factory unless they are requested. Parts that are damaged through carelessness or misuse by the kit builder will not be replaced without cost, and will not be considered in warranty.

Parts are also available at the Heathkit Electronic Centers listed in your catalog. Be sure to provide the Heath part number. Bring in the original part when you request a warranty replacement from a Heathkit Electronic Center.

NOTE: Replacement parts are maintained specifically to repair Heathkit products. Parts sales for other reasons will be declined.

TECHNICAL CONSULTATION

Need help with your kit? Self-Service? Construction? Operation? Call or write for assistance. You'll find our Technical Consultants eager to help with just about any technical problem except "customizing" for unique applications.

The effectiveness of our consultation service depends on the information you furnish. Be sure to tell us:

- The Model number and Series number from the blue and white label.
- The date of purchase.
- An exact description of the difficulty.
- Everything you have done in attempting to correct the problem.

Also include switch positions, connections to other units, operating procedures, voltage readings, and any other information you think might be helpful.

Please do not send parts for testing, unless this is specifically requested by our Consultants.

Hints: Telephone traffic is lightest at midweek. . . please be sure your Manual and notes are on hand when you call.

Heathkit Electronic Center facilities are also available for telephone or "walk-in" personal assistance.

REPAIR SERVICE

Service facilities are available, if they are needed, to repair your completed kit. (Kits that have been modified, soldered with paste flux or acid core solder, cannot be accepted for repair.)

If it is convenient, personally deliver your kit to a Heathkit Electronic Center. For warranty parts replacement, supply a copy of the invoice or sales slip.

If you prefer to ship your kit to the factory, attach a letter containing the following information directly to the unit:

- Your name and address.
- Date of purchase.
- Copies of all correspondence relevant to the service of the kit.
- A brief description of the difficulty.
- Authorization to return your kit C.O.D. for the service and shipping charges. (This will reduce the possibility of delay.)

Check the equipment to see that all screws and parts are secured. (Do not include any wooden cabinets or color television picture tubes, as these are easily damaged in shipment.) Place the equipment in a strong carton with at least THREE INCHES of *resilient* packing material (shredded paper, excelsior, etc.) on all sides. Use additional packing material where there are protrusions (control sticks, large knobs, etc.). If the unit weighs over 15 lbs., place this carton in another one with 3/4" of packing material between the two.

Seal the carton with reinforced gummed tape, tie it with a strong cord, and mark it "Fragile" on at least two sides. Remember, the carrier will not accept liability for shipping damage if the unit is insufficiently packed. Ship by prepaid express, United Parcel Service, or insured Parcel Post to:

Heath Company
Service Department
Benton Harbor, Michigan 49022

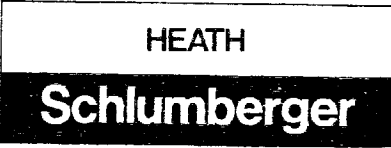

HEATH COMPANY • BENTON HARBOR, MICHIGAN
THE WORLD'S FINEST ELECTRONIC EQUIPMENT IN KIT FORM

LITHO IN U.S.A.

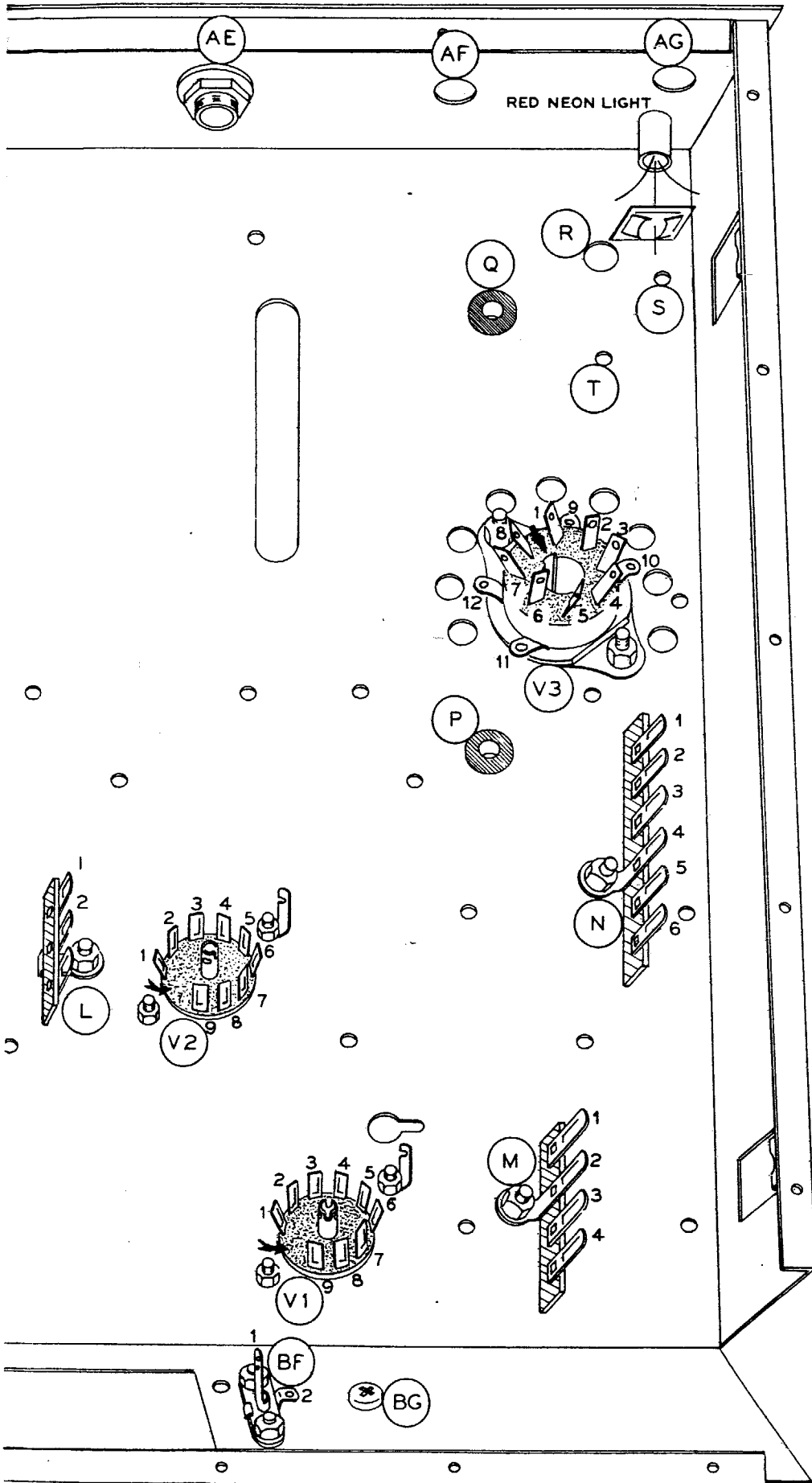

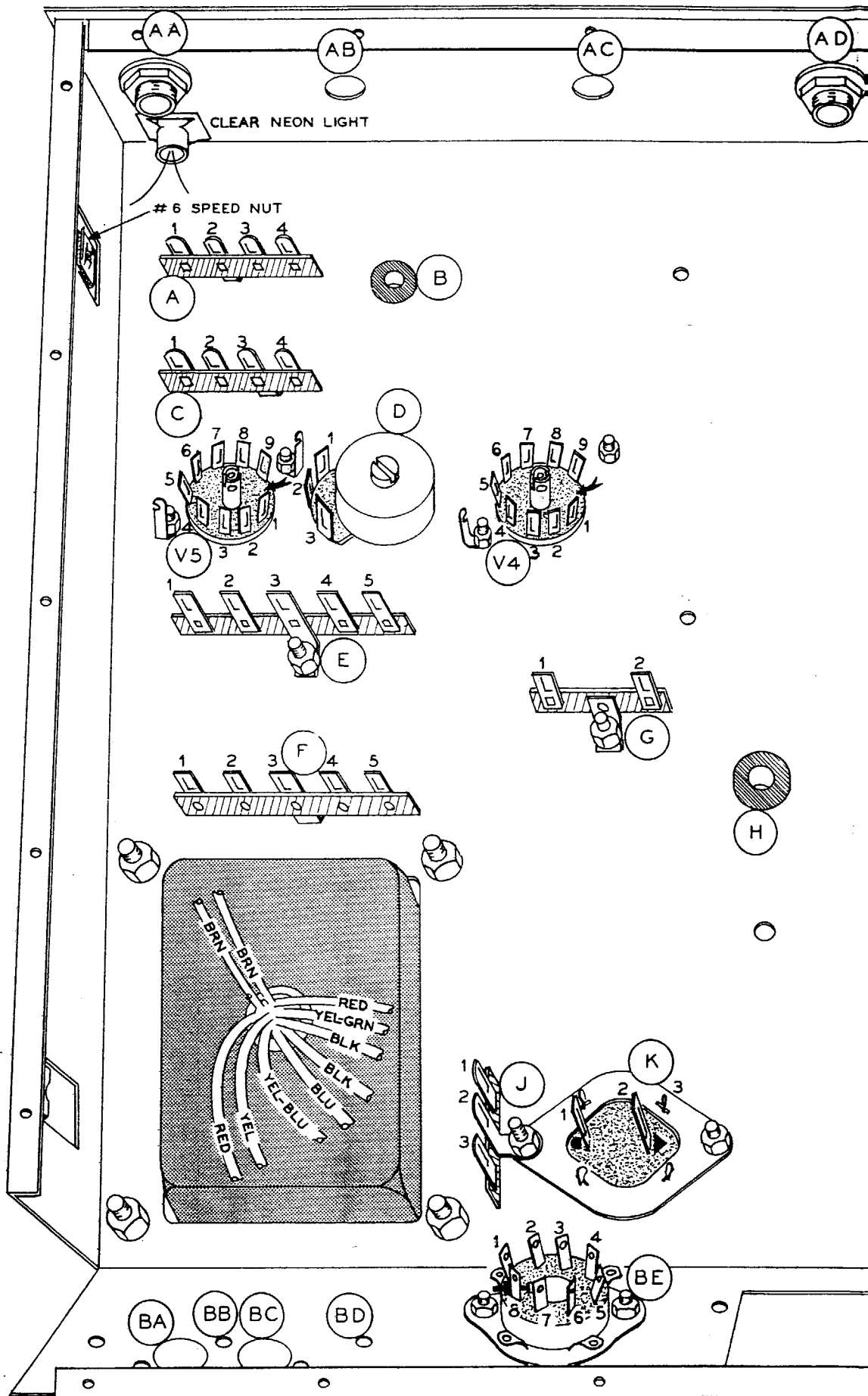

30-4
3/8" RHMS

30-7
1/16" RHMS

0-8
METAL SCREW

1-34
1/2" RHMS

1-49
1/4" BHMS

3-56
1/4" BHMS

1-89
3/8" BHMS

6-32 x 1/4"
D SCREW

1-152
3/4" RHMS

1-1
DE BOLT

COAXIAL JACK

POSITION 2-SECTION ROTARY
DEDED REAR WAFER: SWITCH

#252-1
3-48 NUT

#252-3
6-32 NUT

#252-4
8-32 NUT

#252-7
CONTROL NUT

#252-15
4-40 NUT

#252-22
#6 SPEEDNUT

#252-30
10-24 NUT

#252-31
#10-24 WING NUT

#252-32
PUSH-ON SPEEDNUT

#250-123 10-24 x 2-1/4"
HEX HEAD SCREW

#253-1
#6 FLAT FIBER WASHER

#253-7
#10 FLAT FIBER WASHER

#253-9
#8 FLAT STEEL WASHER

#253-10
CONTROL FLAT WASHER

#253-19
#10 FLAT STEEL WASHER

#254-1
#6 LOCKWASHER

#254-2
#8 LOCKWASHER

#254-3
#10 LOCKWASHER

#254-4 CONTROL
LOCKWASHER

#254-5 THIN
CONTROL LOCKWASHER

#254-7
#3 LOCKWASHER

#254-9
#4 LOCKWASHER

#254-10
EXTERNAL LOCKWASHER

#255-41
#8 SPACERS

#259-1
#6 SOLDER LUG

#259-6
#6 SMALL SOLDER LUG

#205-M269
METER MOUNTING SPACER

#206-M65 LINE
CORD TERMINAL SHIELD

#206-M142
CENTER SHIELD

#259-10
CONTROL SOLDER LUG

#455-9
3/8" BUSHINGS

#57-27
SILICON DIODE

NEON LAMP

#71-4
STANDOFF INSULATOR

#71-5
STANDOFF INSULATOR

#260-10
CERAMIC PLATE CAP

#456-1
FLEXIBLE COUPLER

#456-7
1/4" SHAFT COUPLER

#204-M158
METER MOUNTING BRACKET

#204-M356
CRYSTAL MOUNTING BRACKET



1/2 WATT RESISTOR



1 WATT RESISTOR



2 WATT RESISTOR

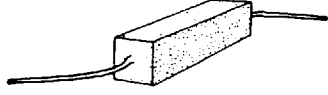

7 WATT WIRE-WOUND RESISTOR

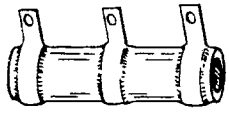

25 WATT WIRE-WOUND CENTER-TAP RESISTOR

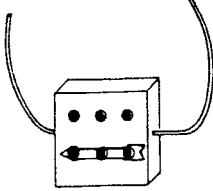

MICA CAPACITOR



SILVER MICA CAPACITOR

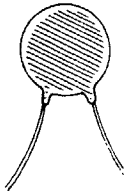

DISC CERAMIC CAPACITOR



FEED-THROUGH CAPACITOR



TUBULAR CAPACITOR

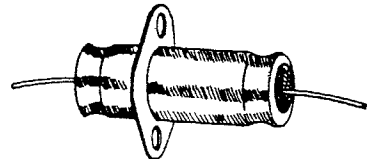

BYPASS FEED-THROUGH CAPACITOR

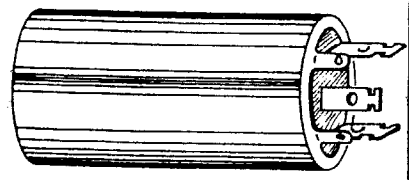

ELECTROLYTIC CAPACITOR

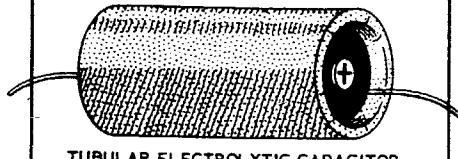

TUBULAR ELECTROLYTIC CAPACITOR

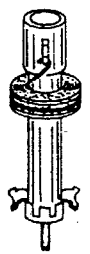

#40-79 COIL

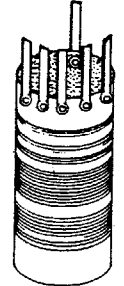

#40-337 DRIVER PLATE COIL

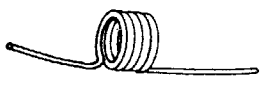

#40-347 #40-348 #40-349 LOW-PASS FILTER COIL



#45-3 RF CHOKE

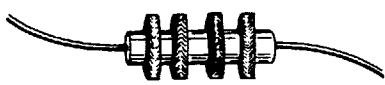

#45-4 RF CHOKE



#45-19 PARASITIC CHOKE

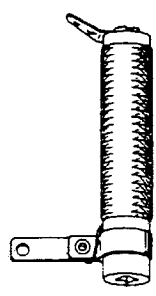

#45-41 RF PLATE CHOKE

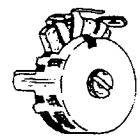

#10-58 CONTROL

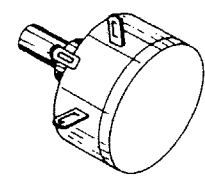

#11-20 WIRE-WOUND CONTROL

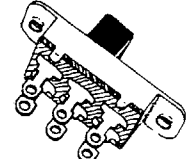

#60-15 SLIDE SWITCH

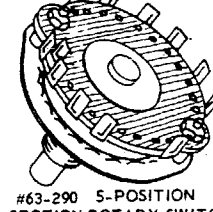

#63-290 5-POSITION 1-SECTION ROTARY SWITCH



#431-1 2-LUG TERMINAL STRIP

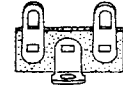

#431-2 2-LUG TERMINAL STRIP

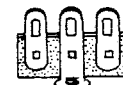

#431-10 3-LUG TERMINAL STRIP



#431-12 4-LUG TERMINAL STRIP

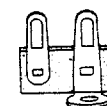

#431-14 2-LUG TERMINAL STRIP

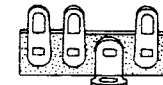

#431-27 3-LUG TERMINAL STRIP



#431-40 4-LUG TERMINAL STRIP

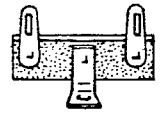

#431-41 HV 2-LUG TERMINAL STRIP

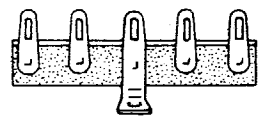

#431-42 HV 5-LUG TERMINAL STRIP

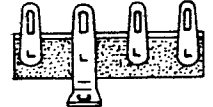

#431-44 HV 4-LUG TERMINAL STRIP

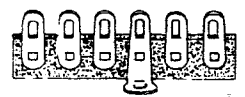

#431-45 6-LUG TERMINAL STRIP

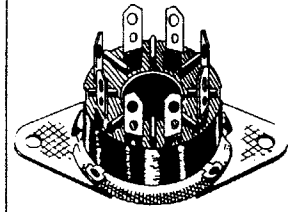

#434-39 OCTAL TUBE SOCKET

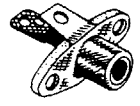

#434-42 PHONO CONNECTOR

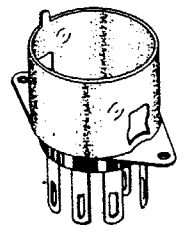

#434-43 9-PIN TUBE SOCKET

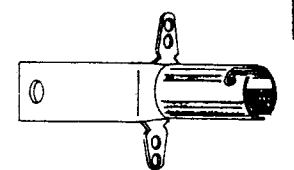

#434-44 PILOT LIGHT SOCKET

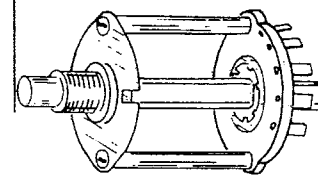

#436-5

#63-24 EX

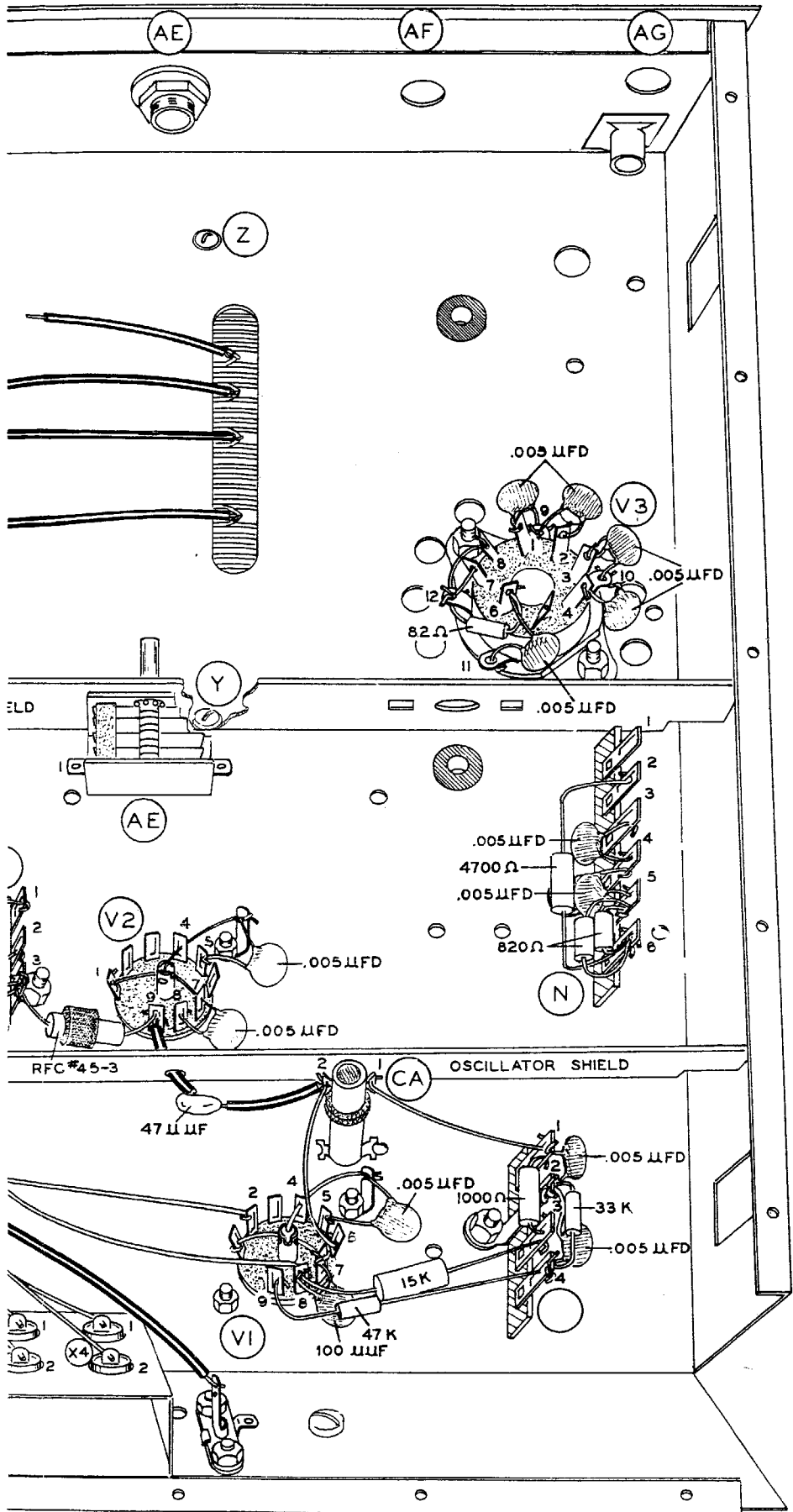

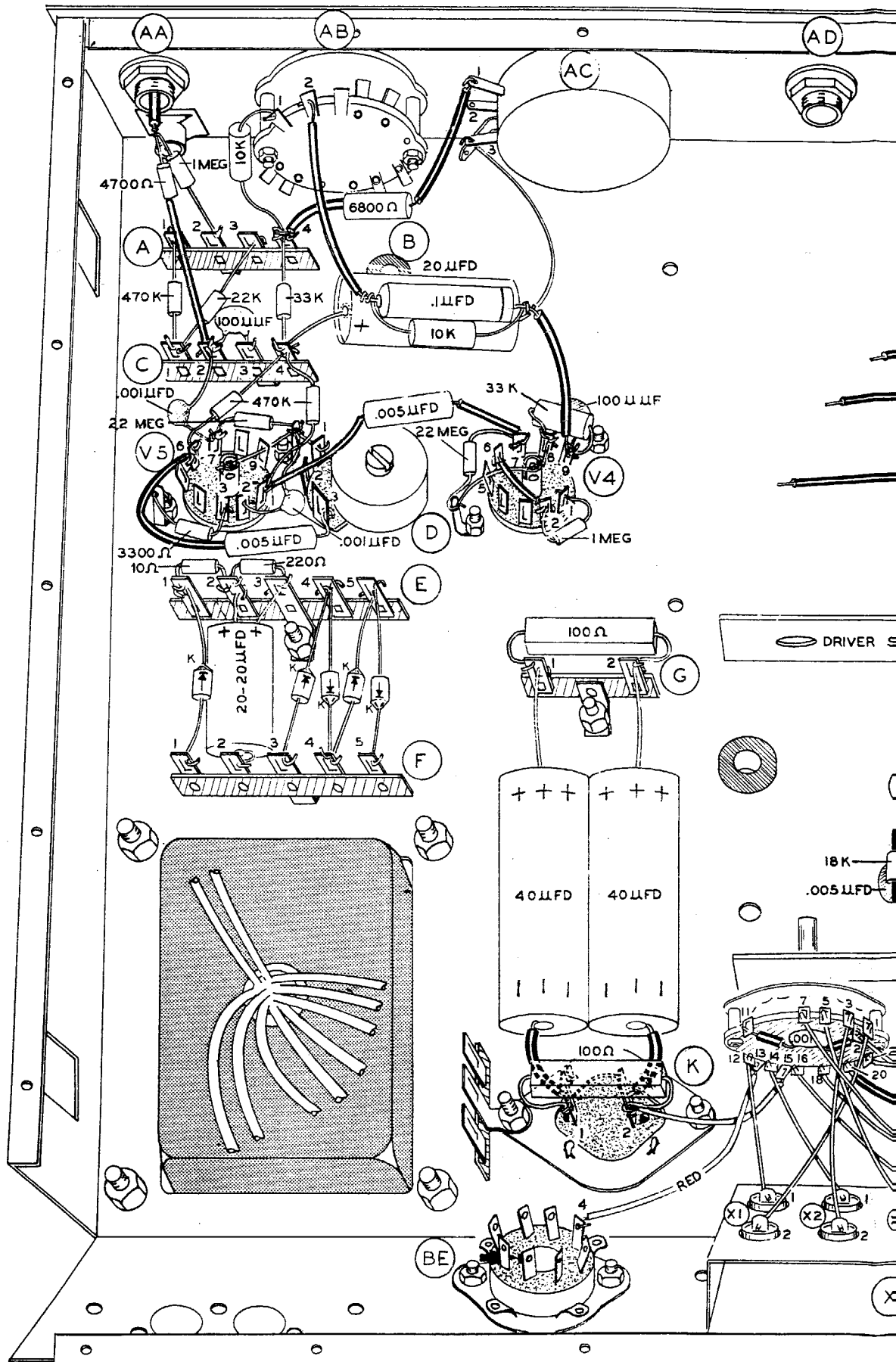

Pictorial 3

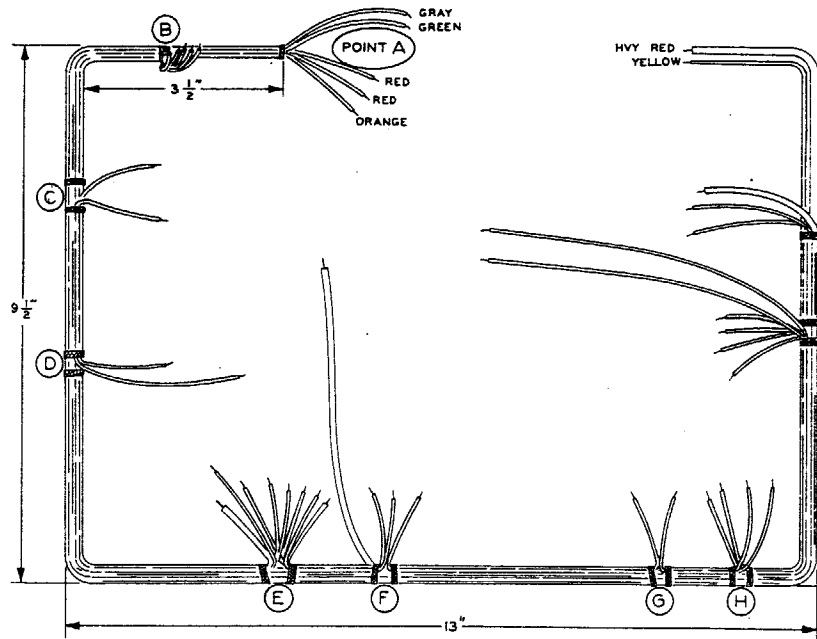
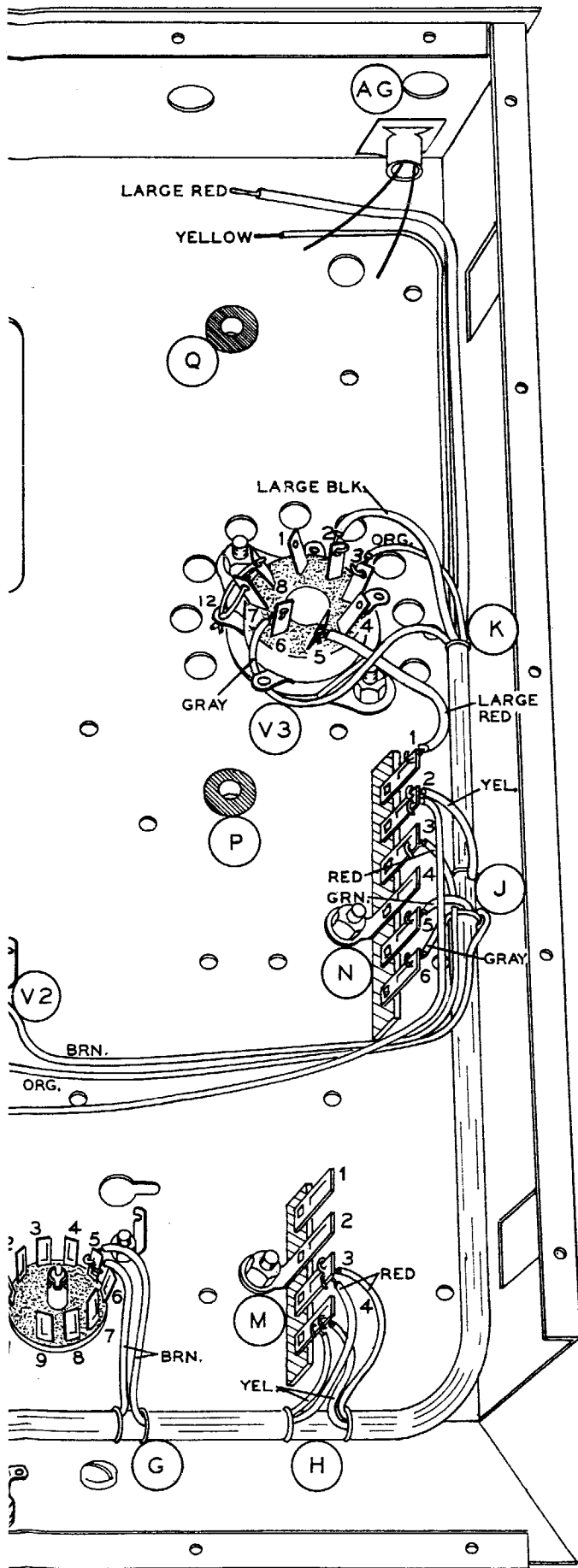

Detail 2A

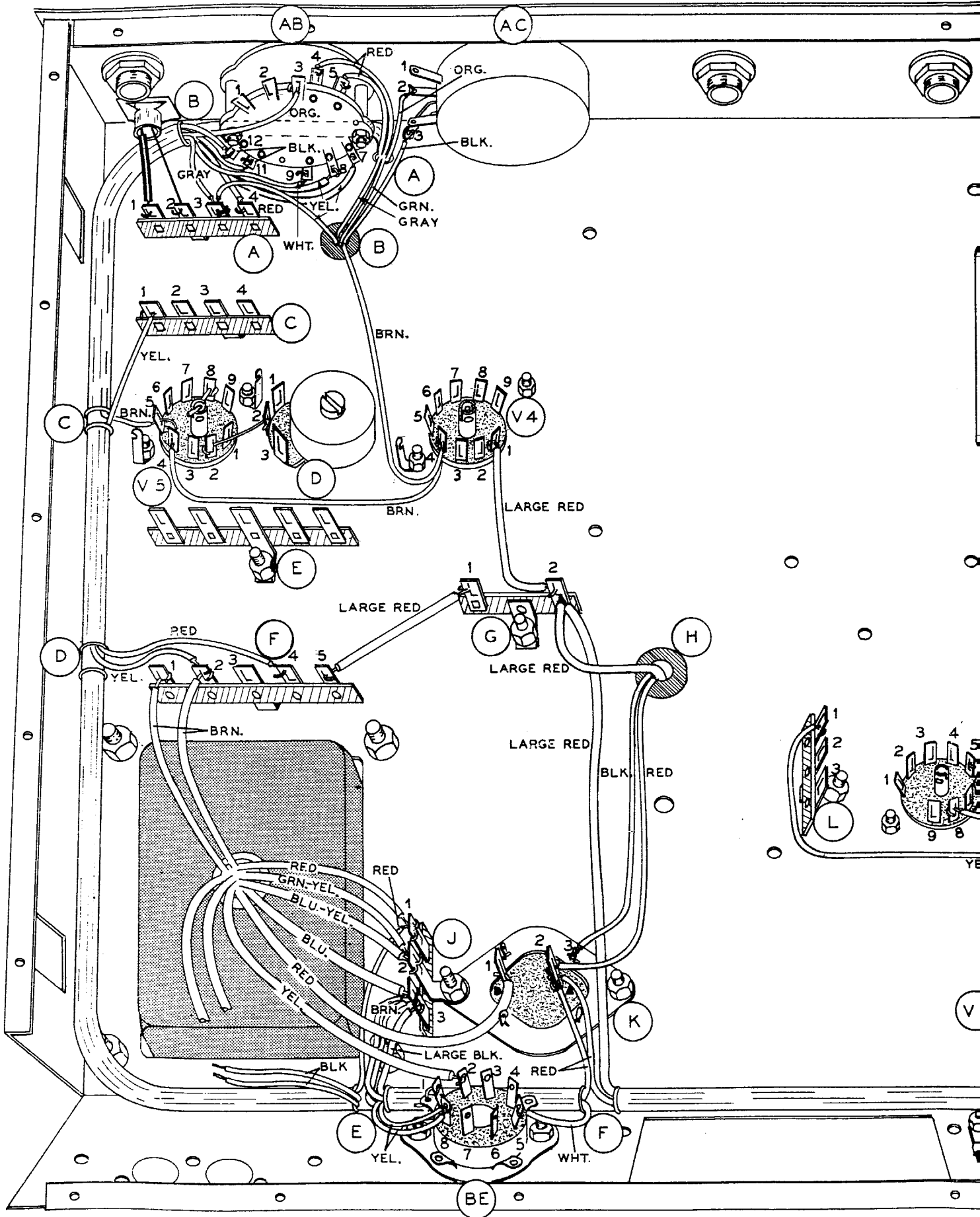

Pictorial 2

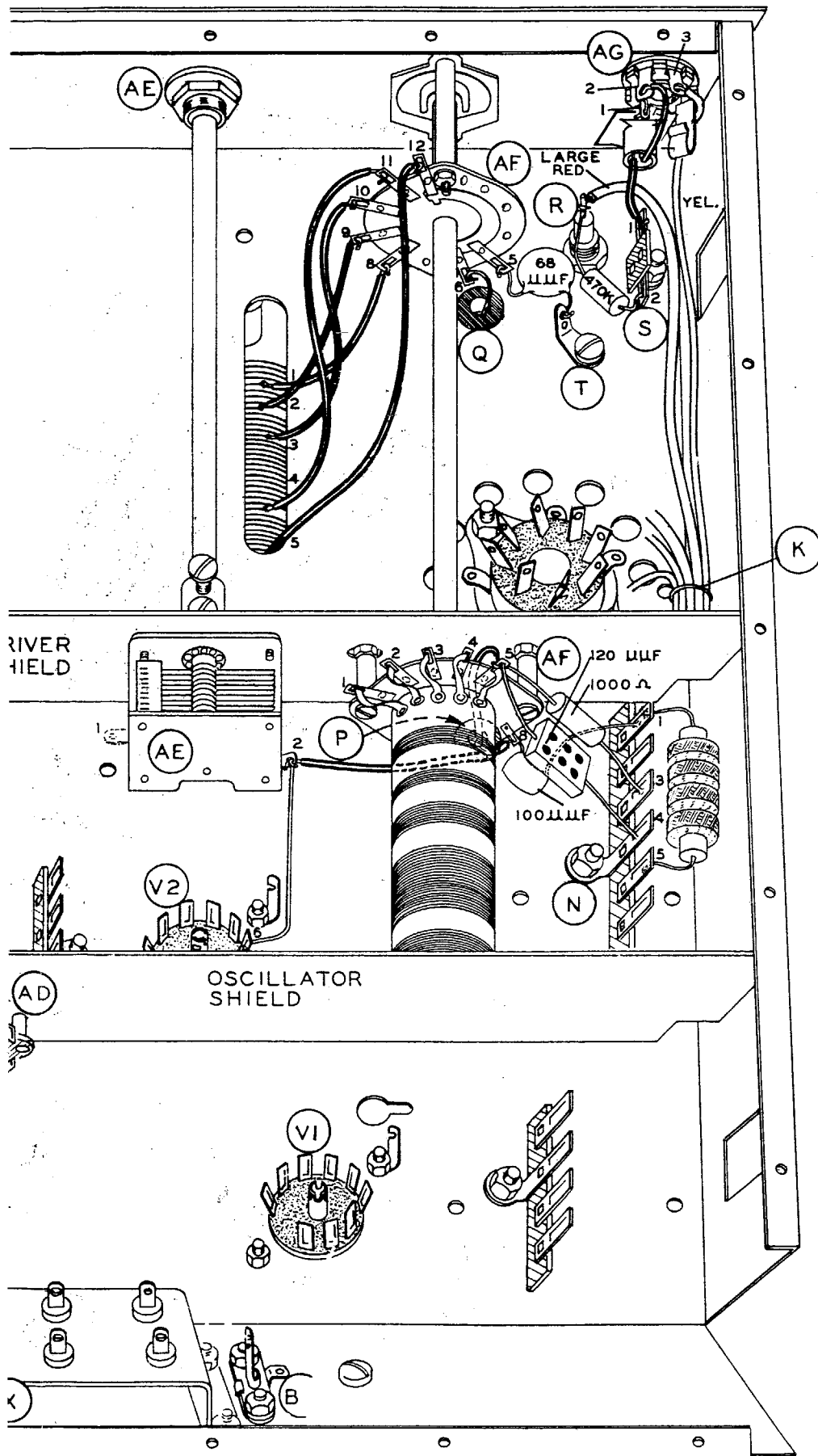

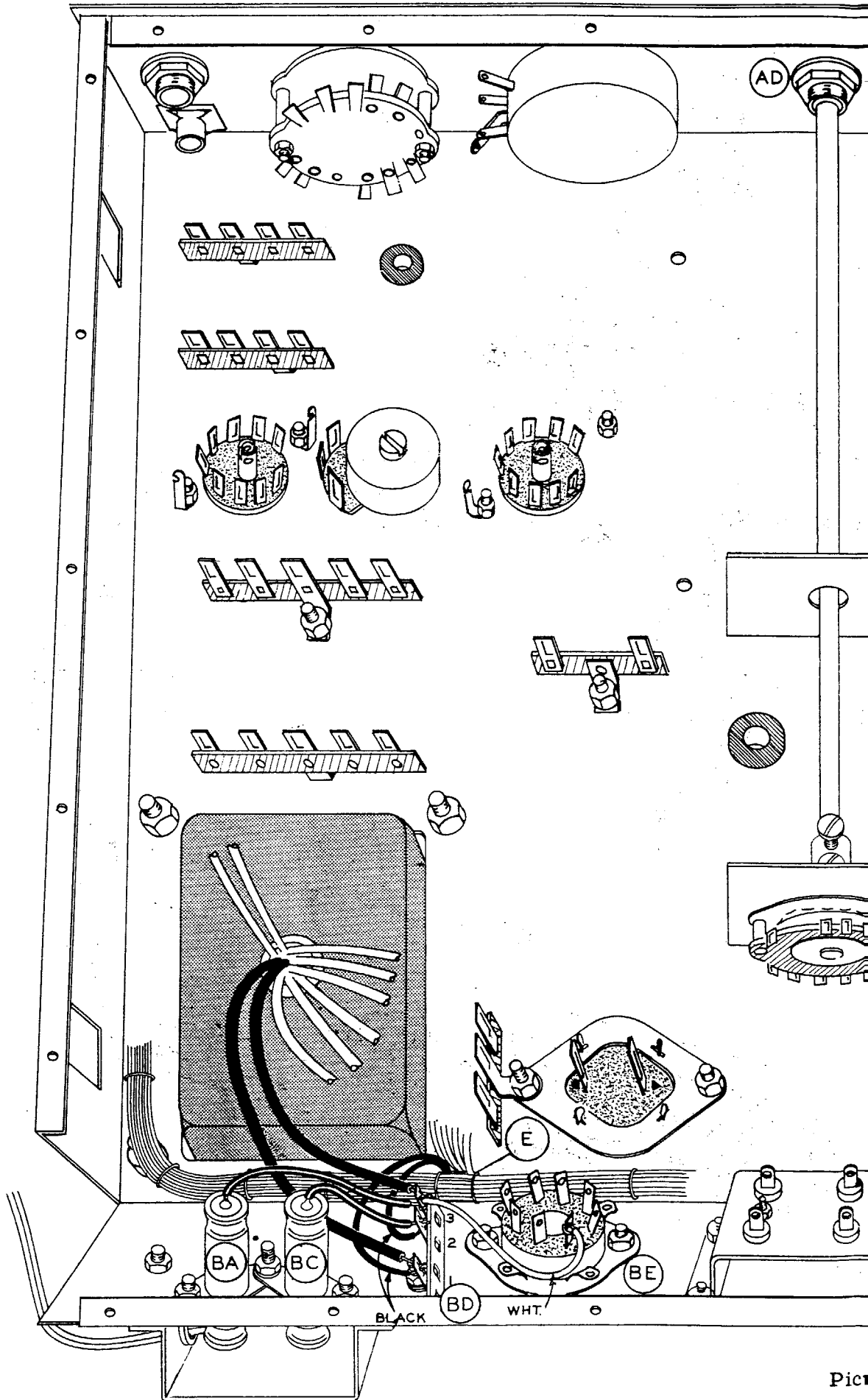

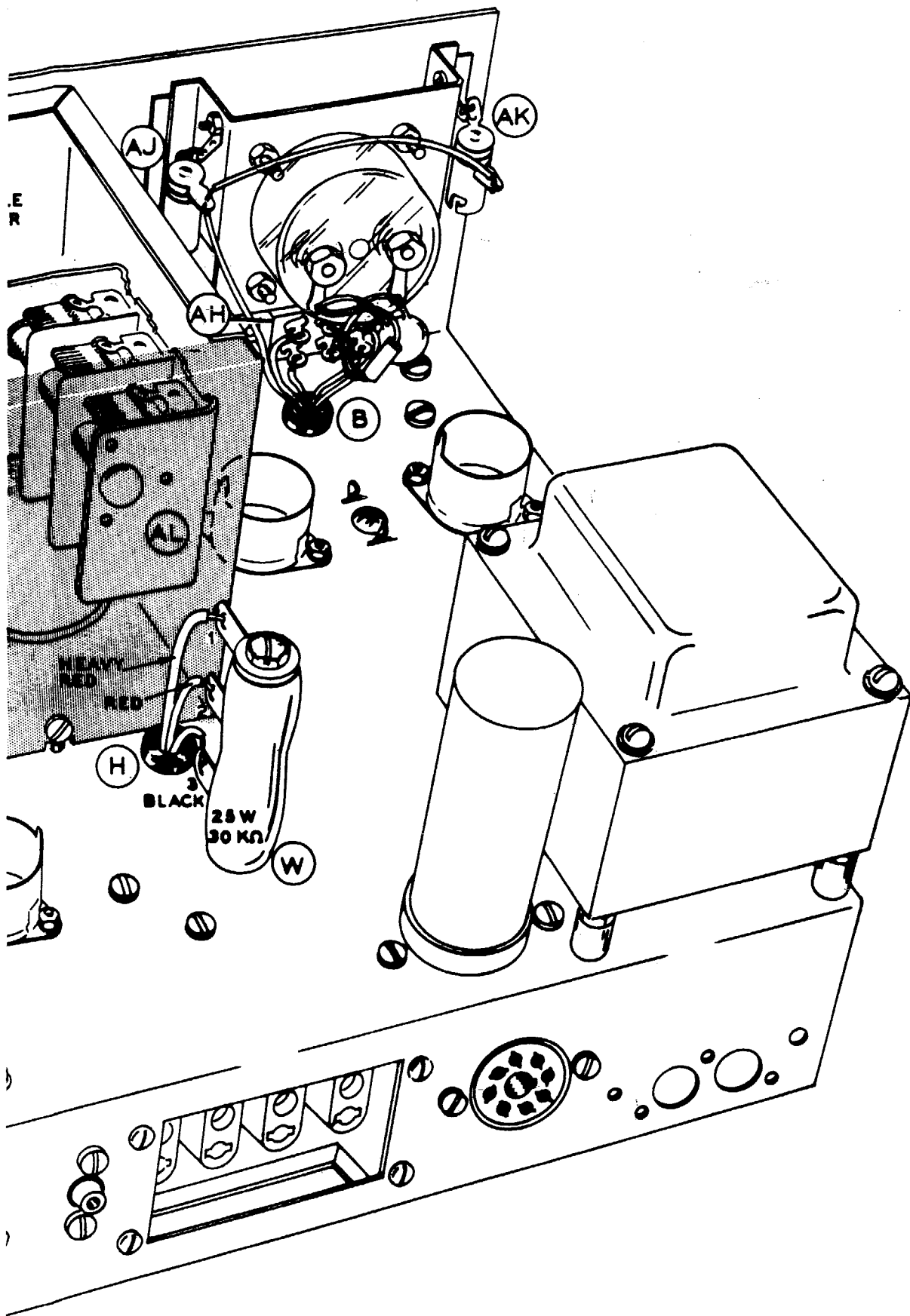

Pictorial 4

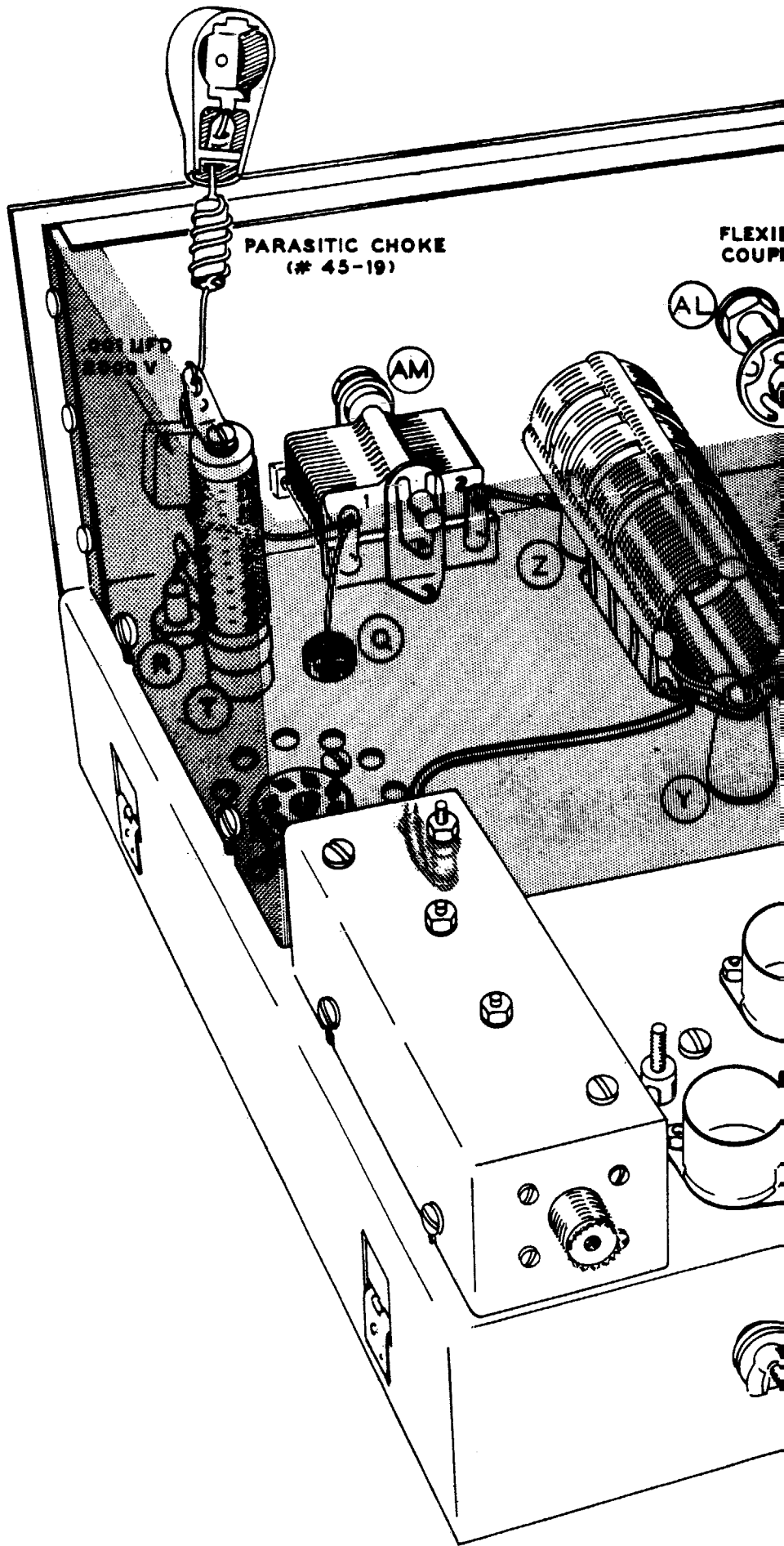

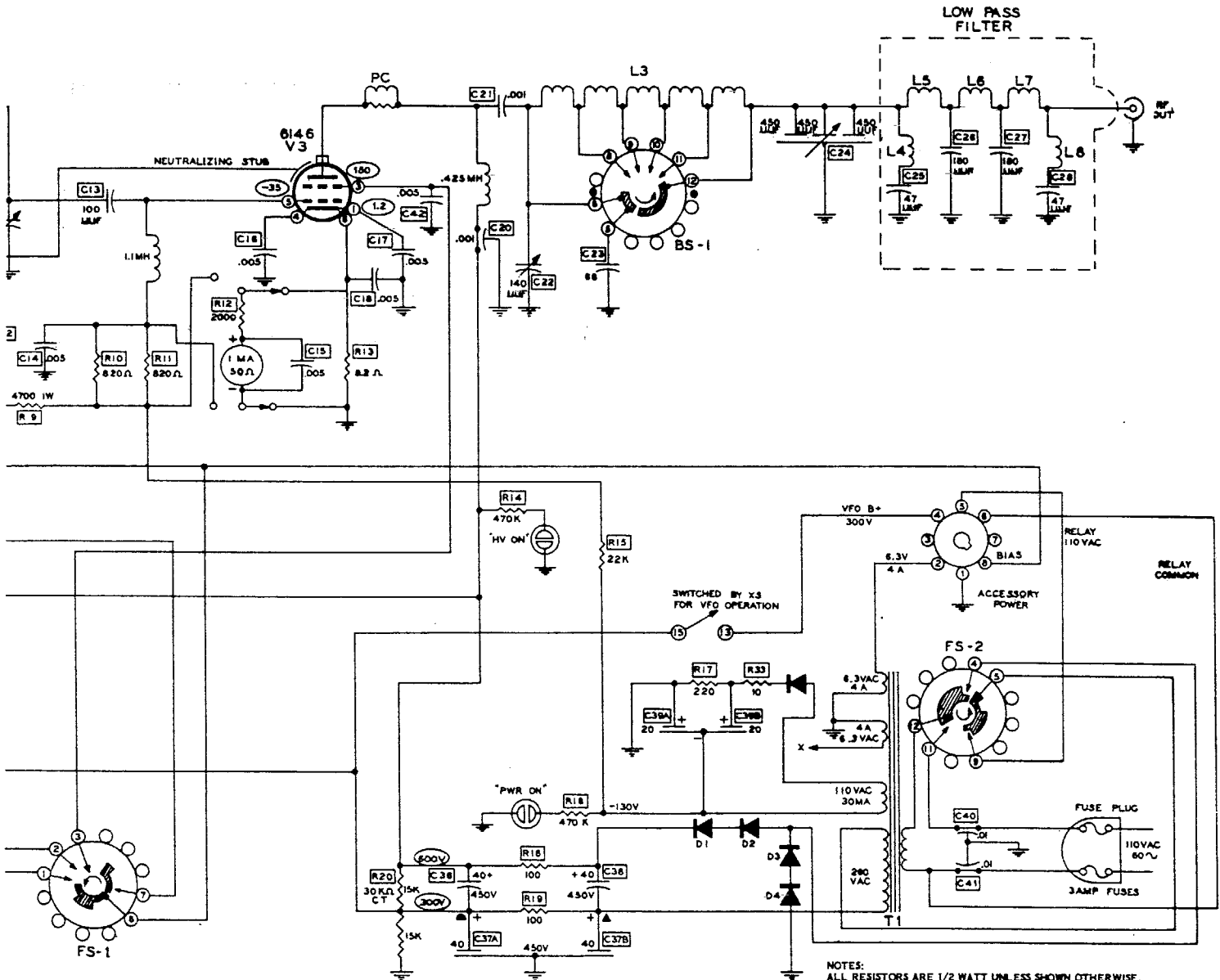

AMATEUR TRANSMITTER
MODEL DX-60

NOTES:
 ALL RESISTORS ARE 1/2 WATT UNLESS SHOWN OTHERWISE.
 ALL CAPACITOR VALUES IN μF UNLESS SHOWN OTHERWISE.
 ALL RESISTOR VALUES ARE IN OHMS (K = 1,000 OHMS, MEG = 1,000,000 OHMS).
 ALL VOLTAGE READINGS ARE DC FROM POINT INDICATED TO CHASSIS GROUND.
 (EXCEPT AC VOLTAGES ON POWER TRANSFORMER WINDINGS).
 READINGS WERE TAKEN WITH 11 MEGOHM INPUT VTVM.
 ALL VOLTAGES TAKEN IN PHONE POSITION.
 SWITCHES VIEWED FROM REAR.
 BAND SWITCH SHOWN IN 80 METER POSITION.
 FUNCTION SWITCH SHOWN IN OFF POSITION.

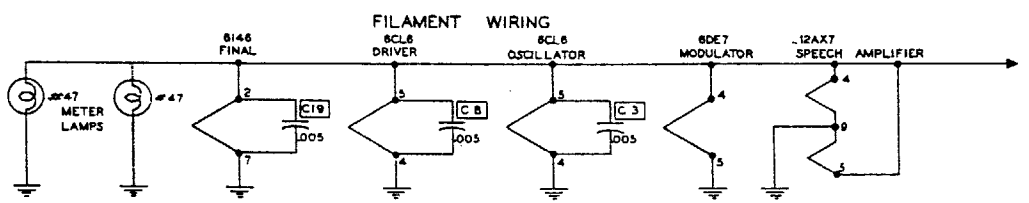
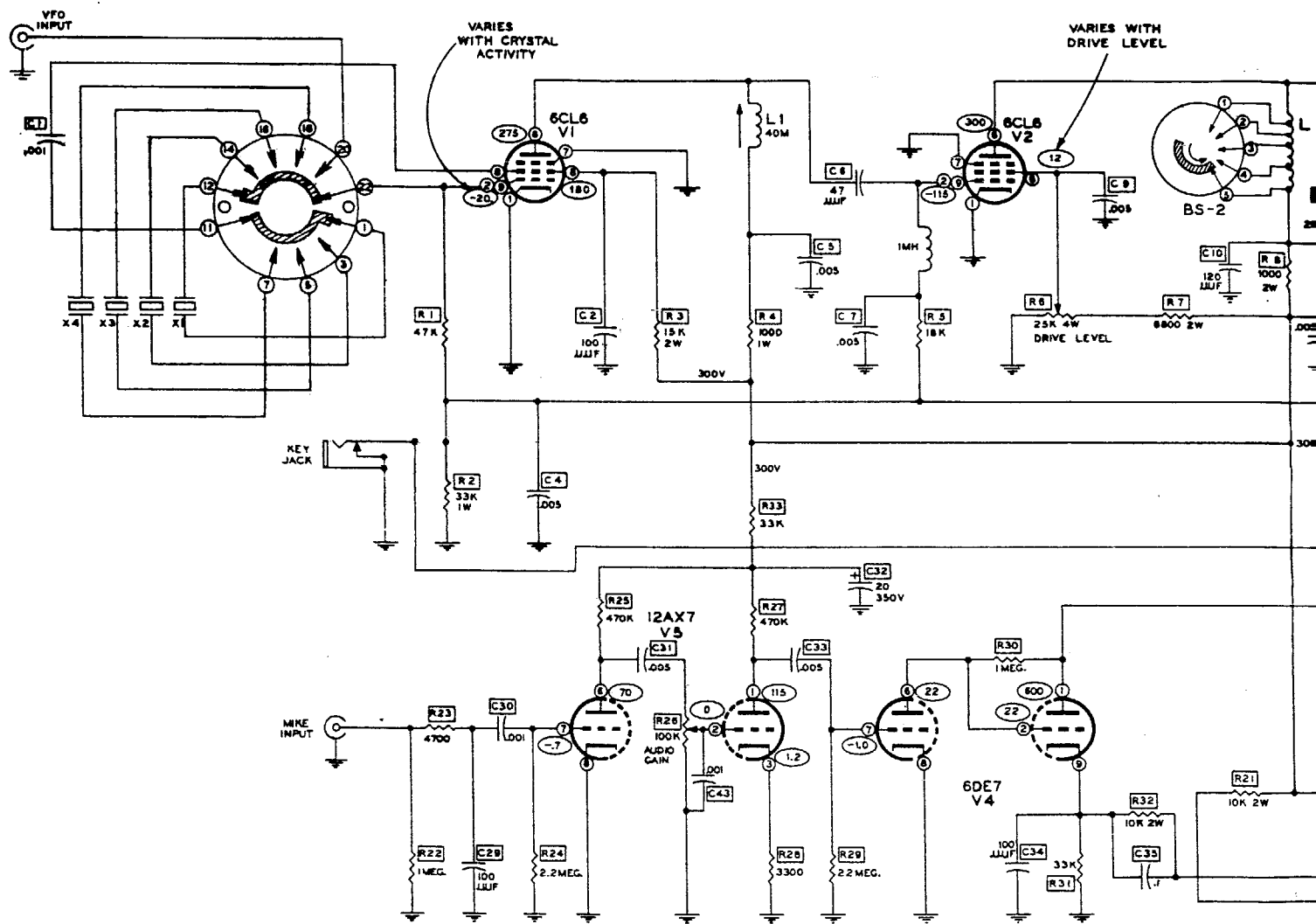

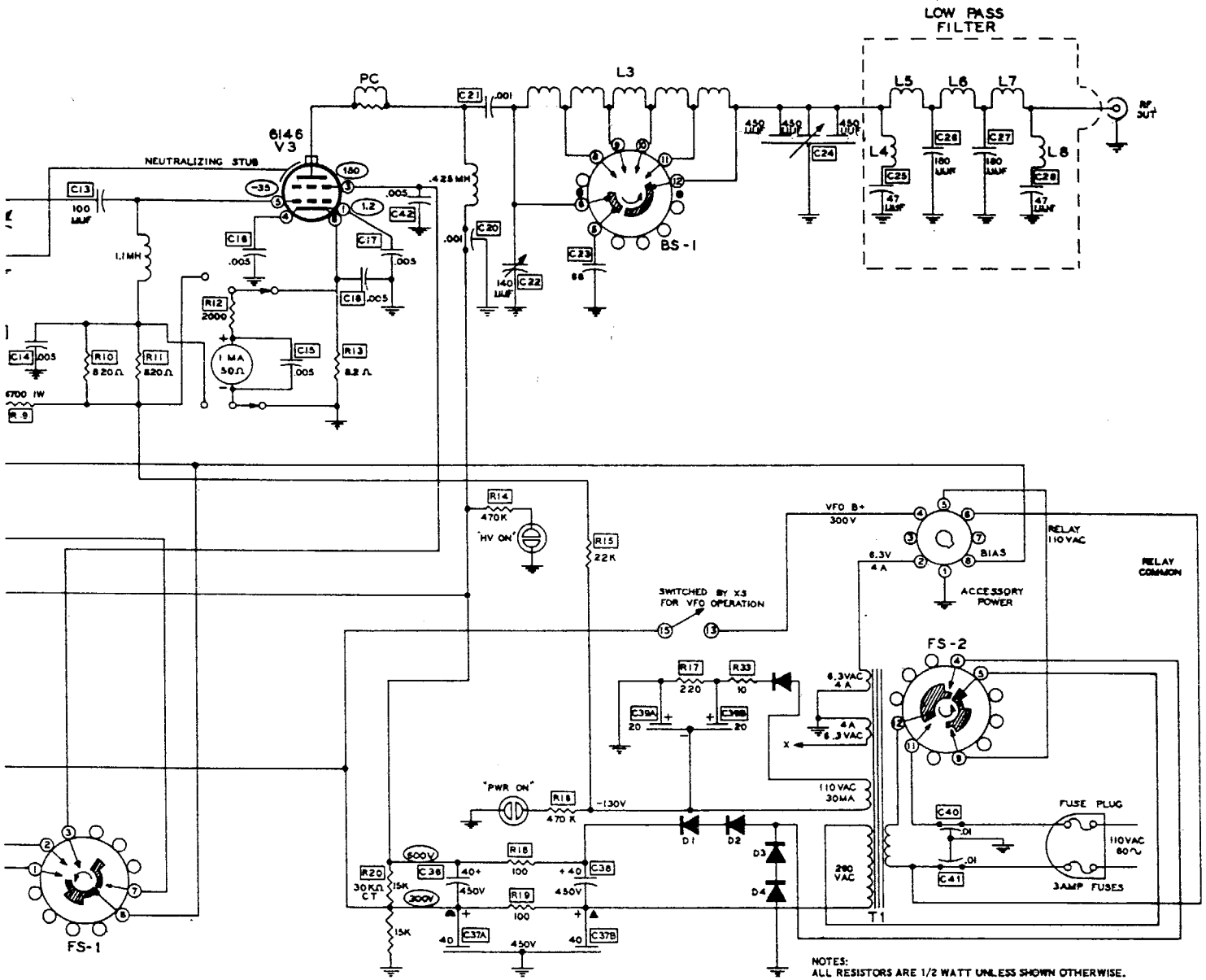

NOTES:
 ALL RESISTORS ARE 1/2 WATT UNLESS SHOWN OTHERWISE.
 ALL CAPACITOR VALUES IN μ F UNLESS SHOWN OTHERWISE.
 ALL RESISTOR VALUES ARE IN OHMS (K = 1,000 OHMS, MEG = 1,000,000 OHMS).
 ALL VOLTAGE READINGS ARE DC FROM POINT INDICATED TO CHASSIS GROUND.
 (EXCEPT AC VOLTAGES ON POWER TRANSFORMER WINDINGS.)
 READINGS WERE TAKEN WITH 11 MEGOHM INPUT VTVM.
 ALL VOLTAGES TAKEN IN PHONE POSITION.
 SWITCHES VIEWED FROM REAR.
 BAND SWITCH SHOWN IN 80 METER POSITION.
 FUNCTION SWITCH SHOWN IN OFF POSITION.



ATEUR TRANSMITTER
 MODEL DX-60

