

PRICE \$2.00

HEATH COMPANY • BENTON HARBOR, MICHIGAN

# HEATHKIT® ASSEMBLY MANUAL



## RF SIGNAL GENERATOR

MODEL IG-102

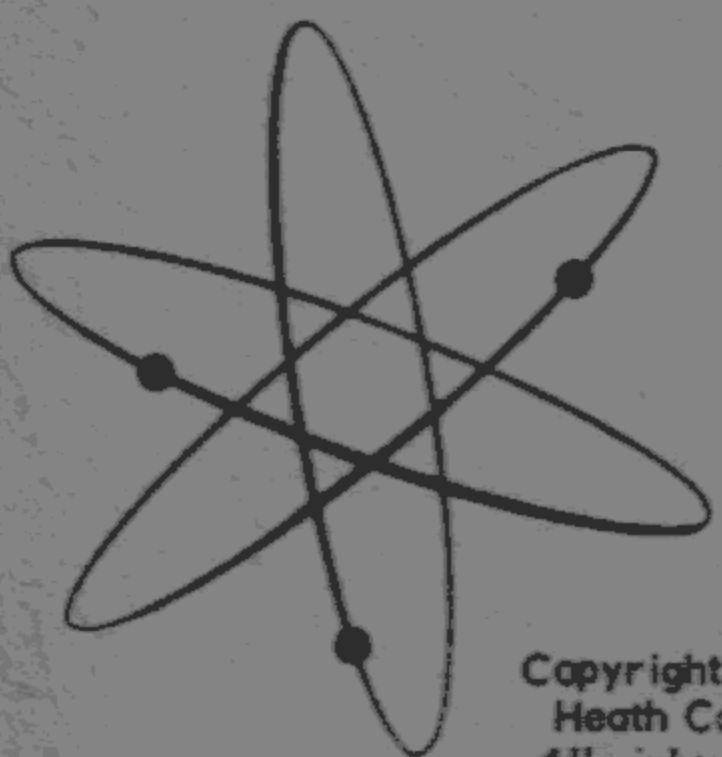











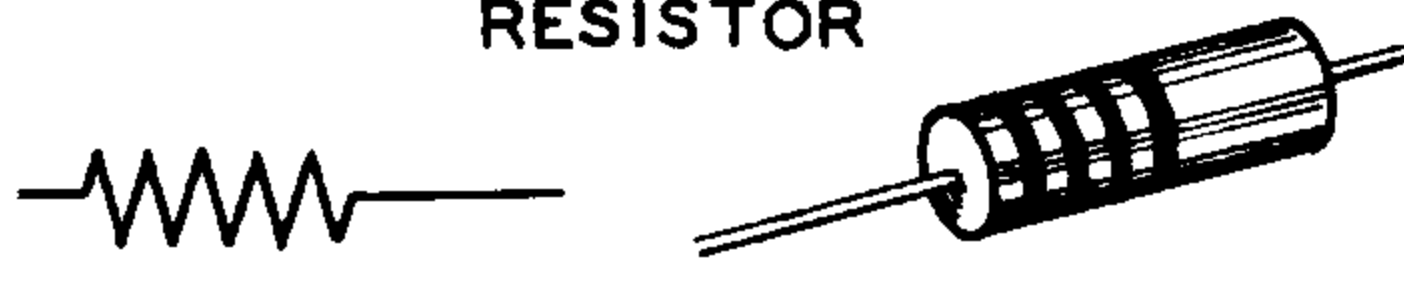

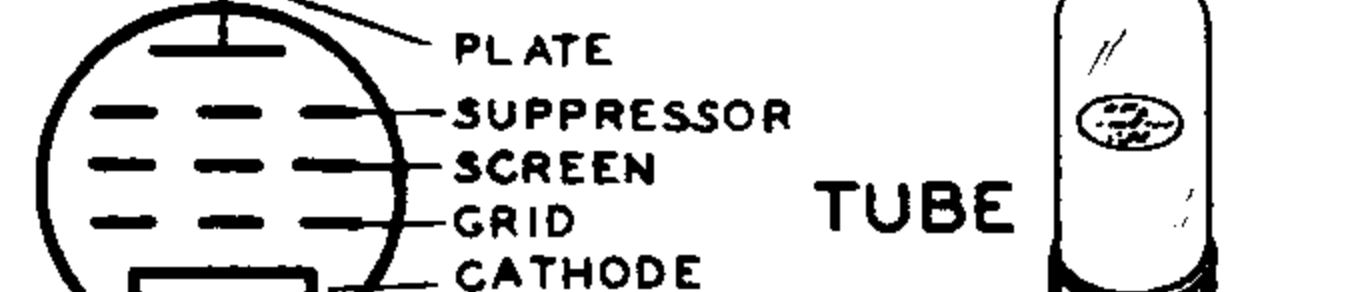
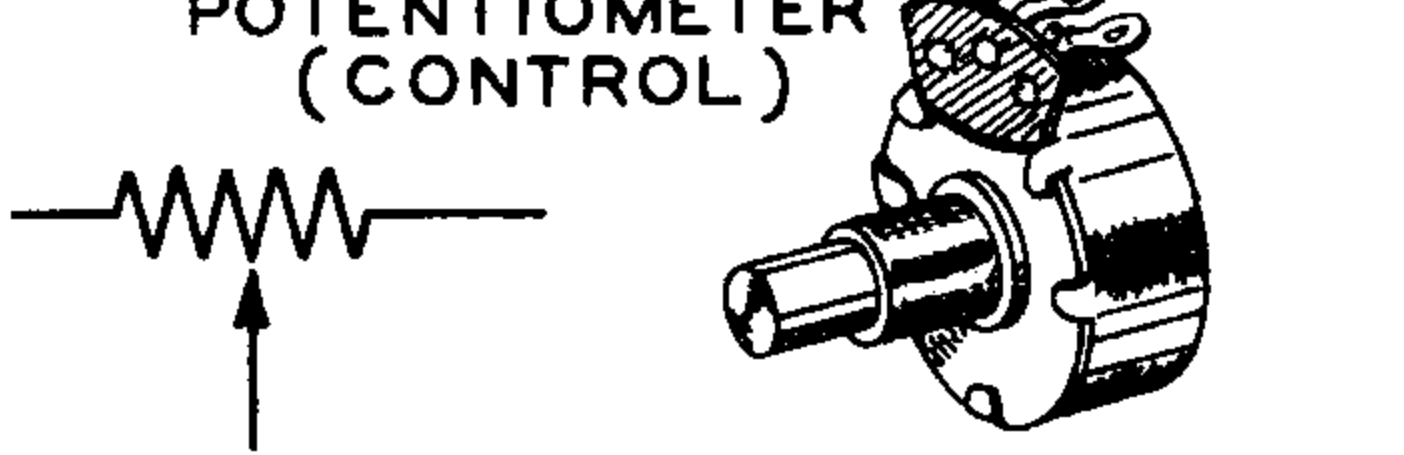
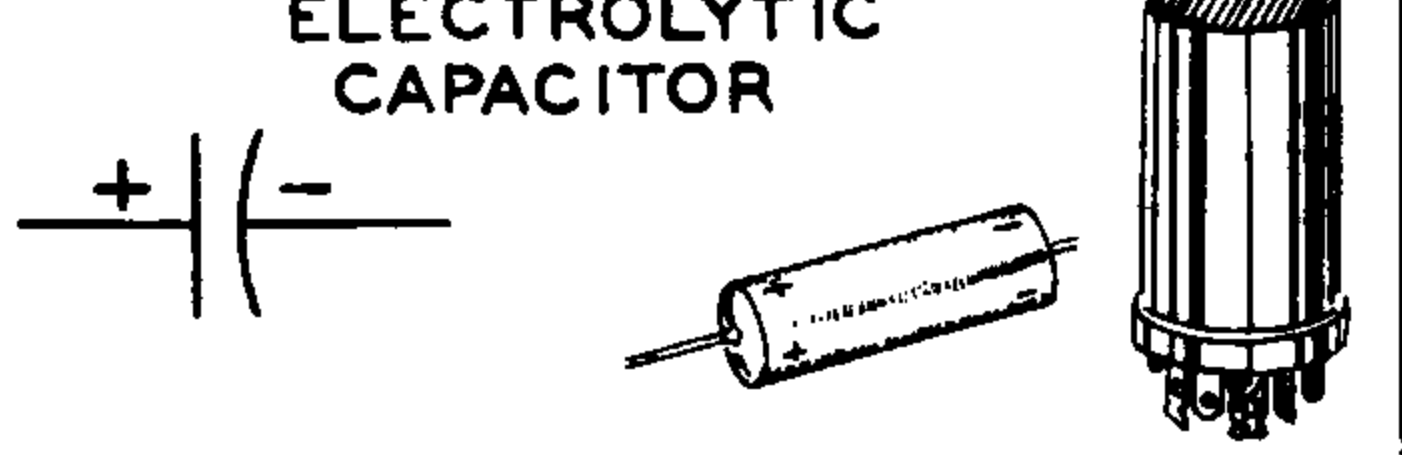
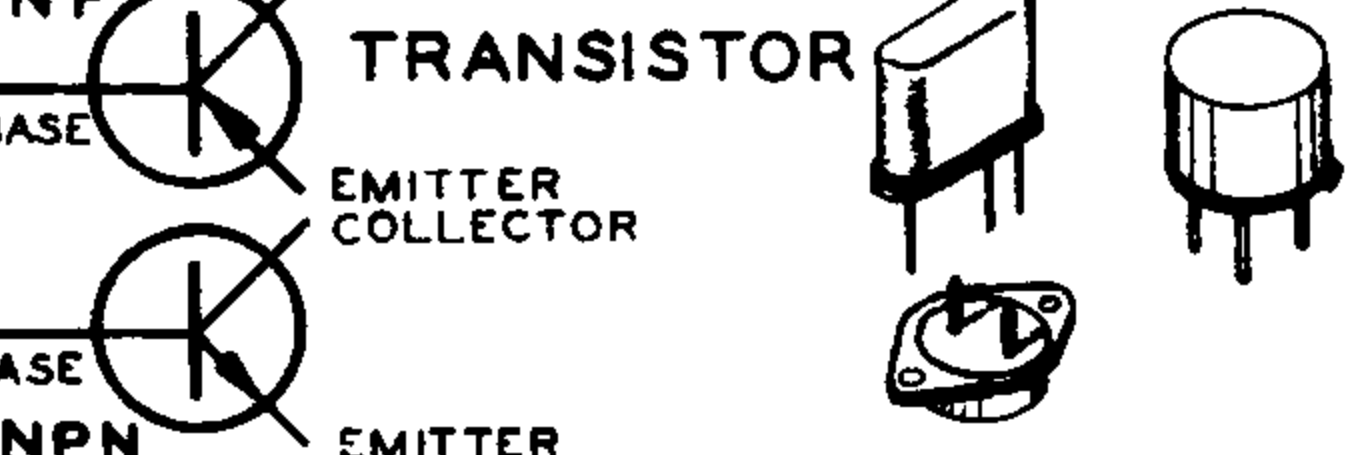
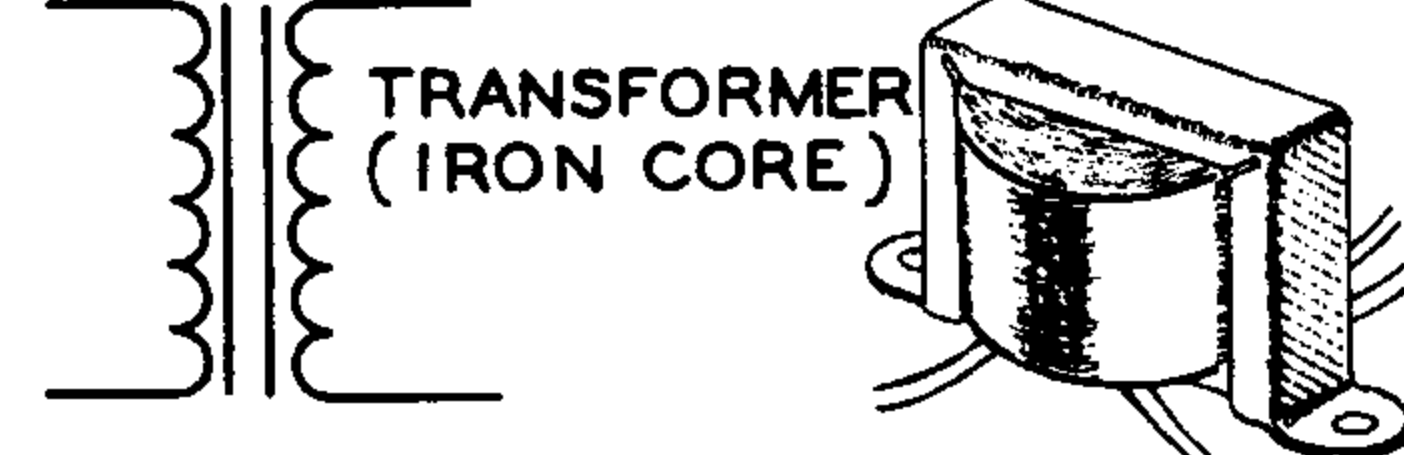
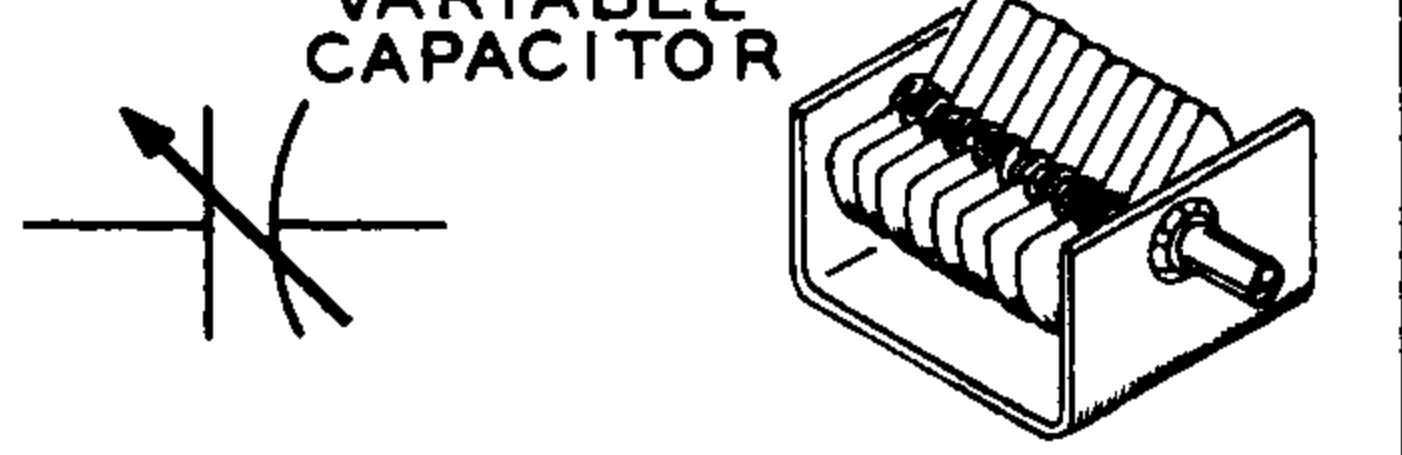
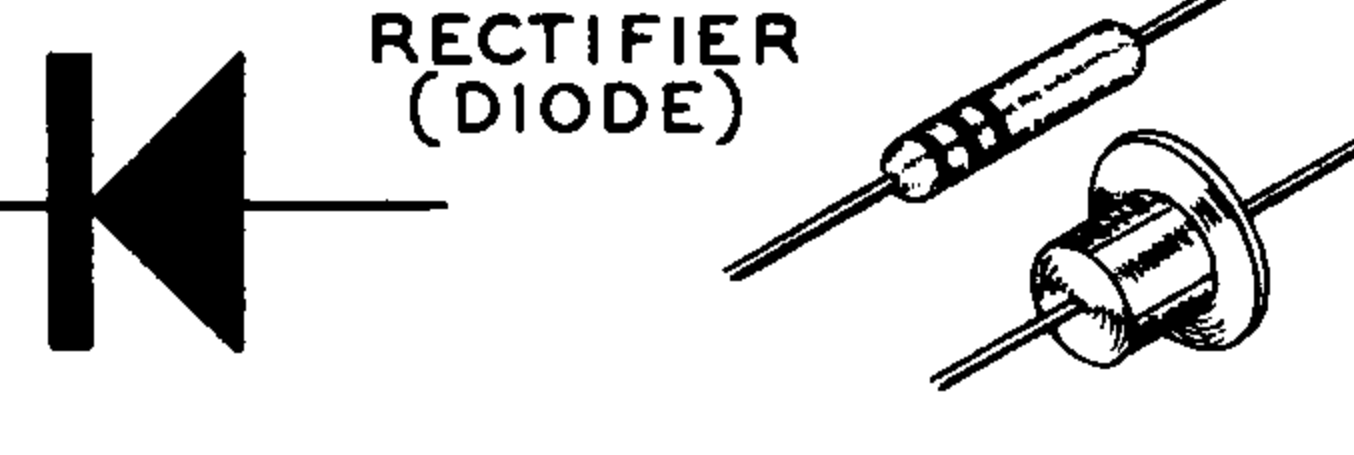
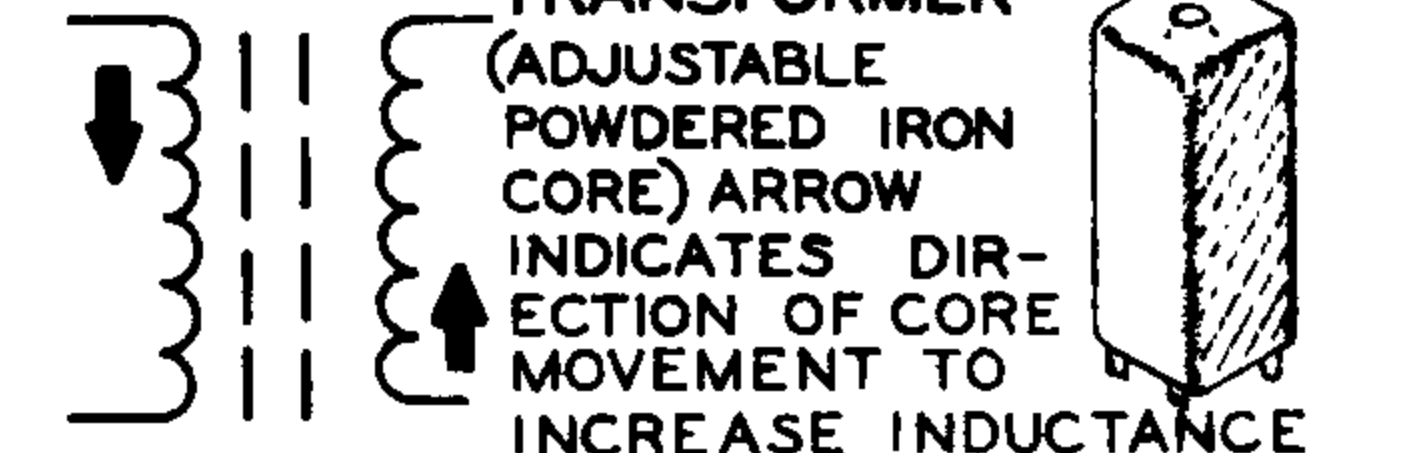
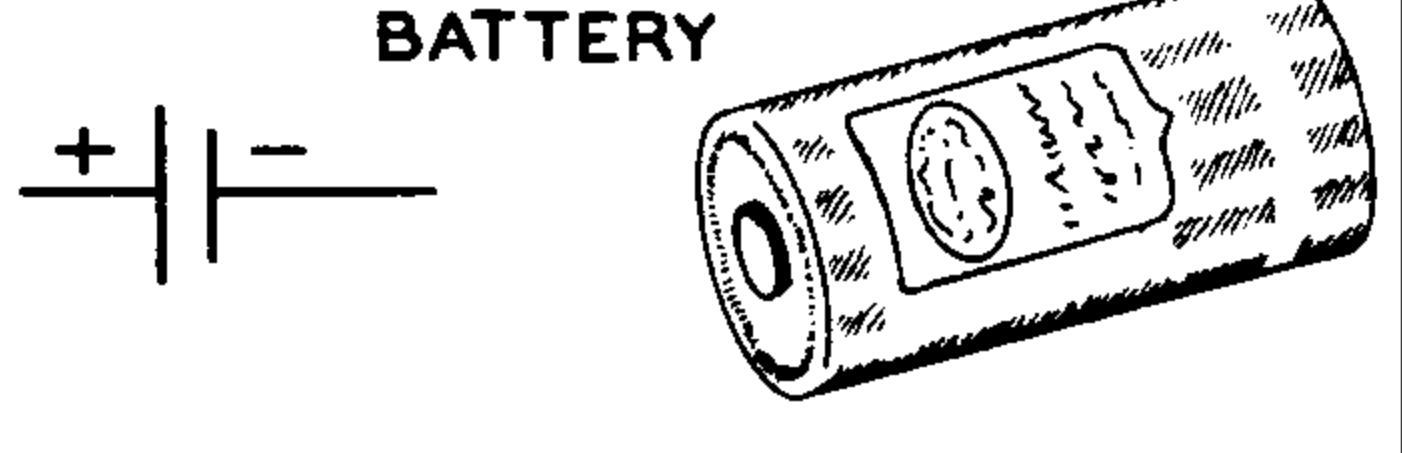
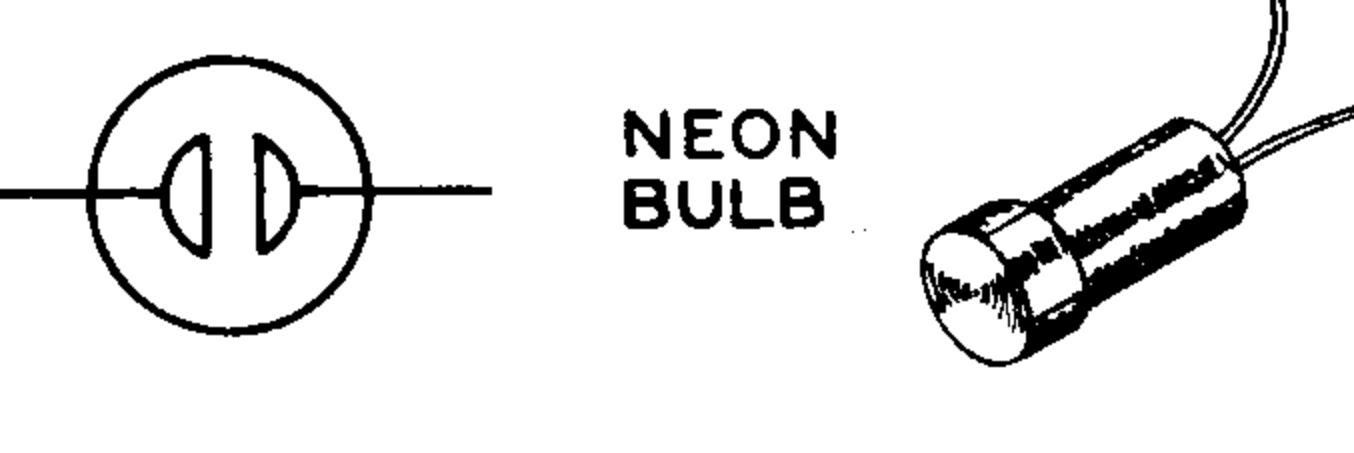
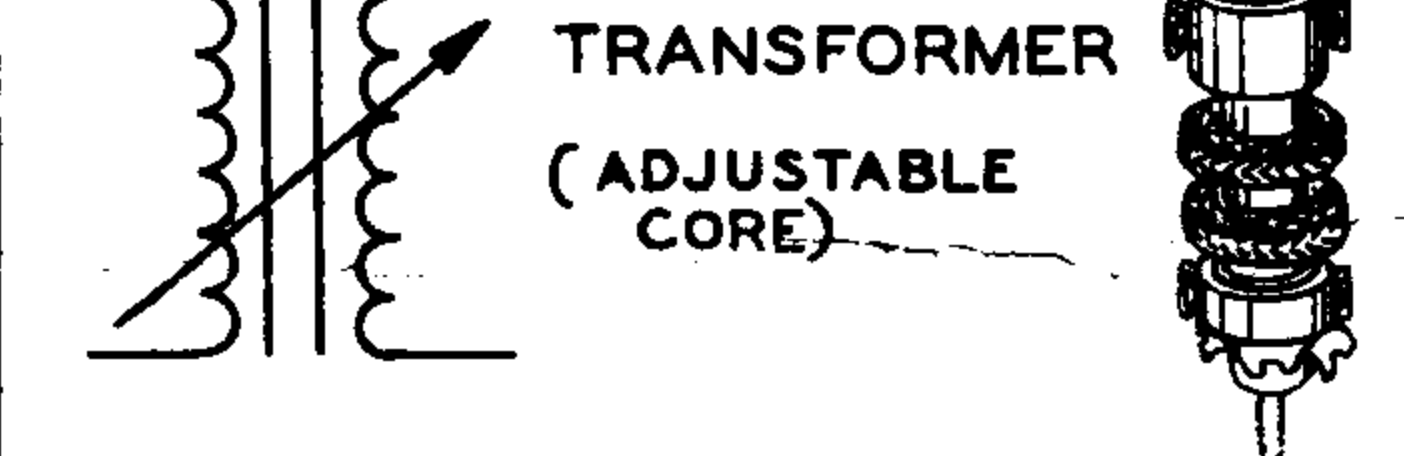
Copyright © 1962  
Heath Company  
All rights reserved

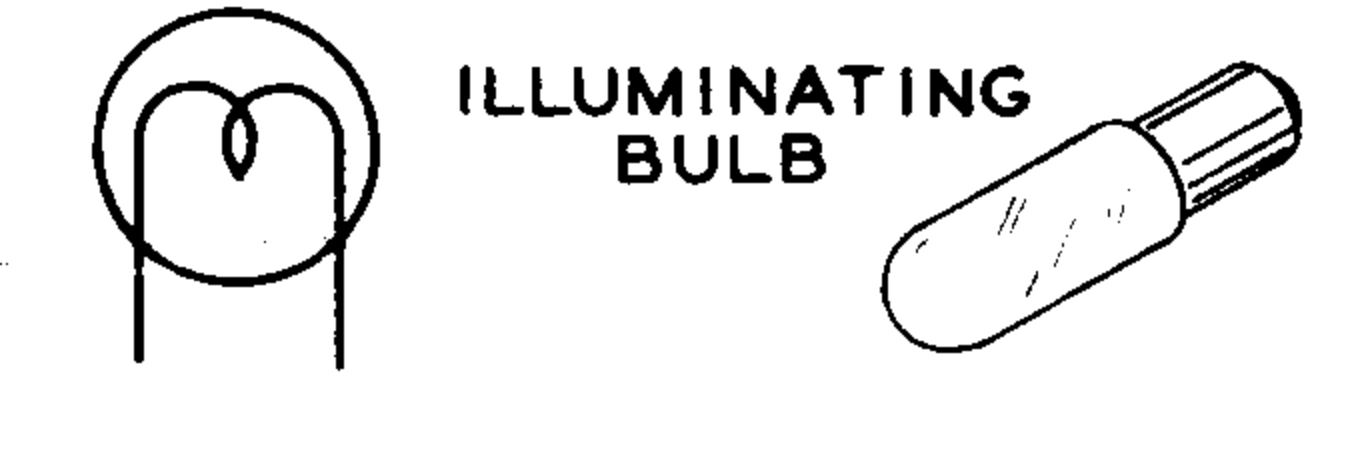
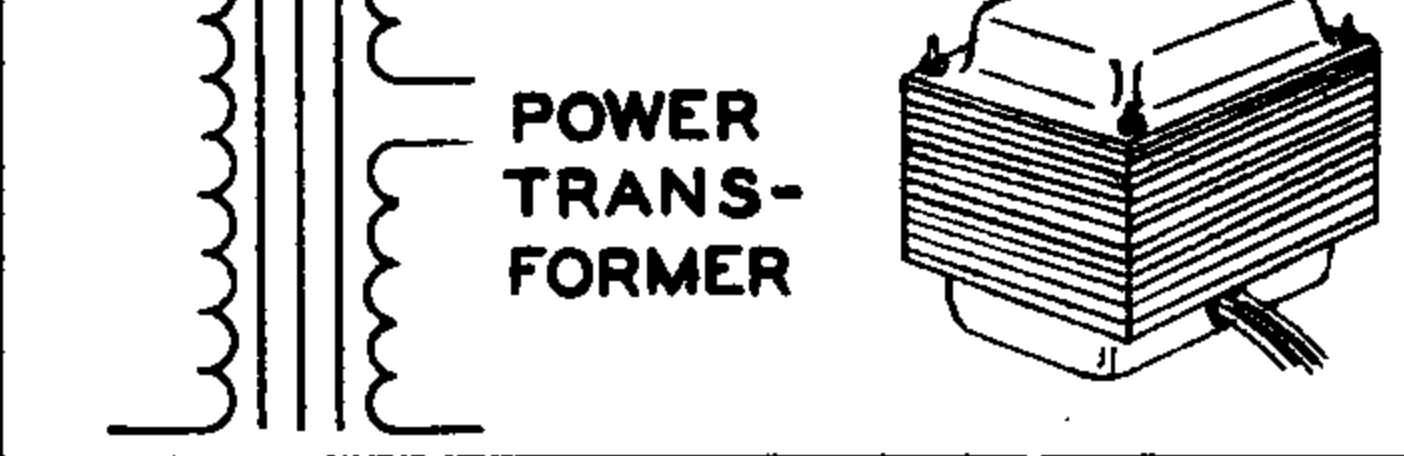
595-565-01  
9-26-69

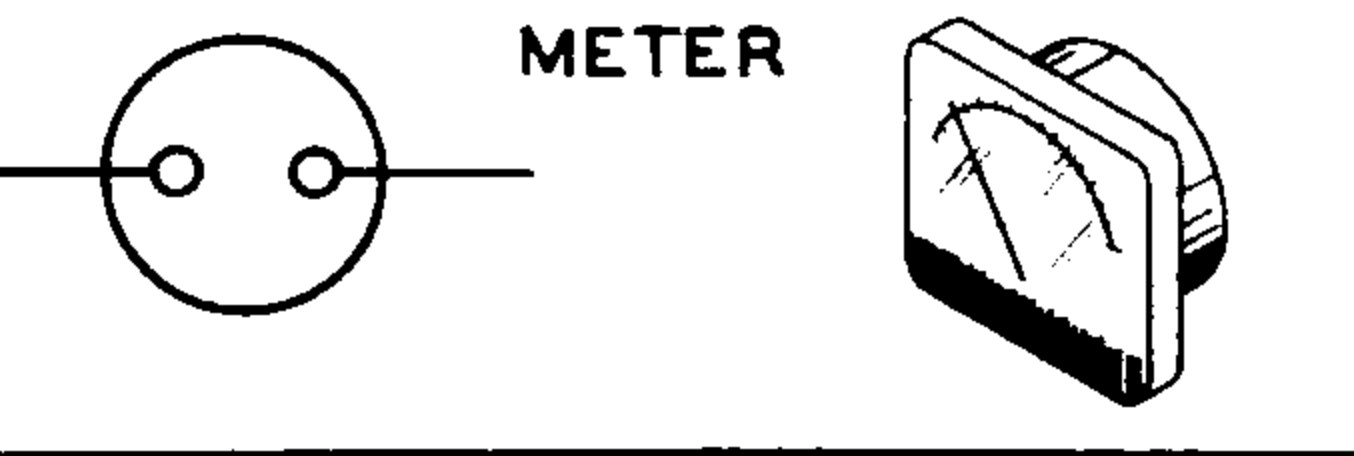
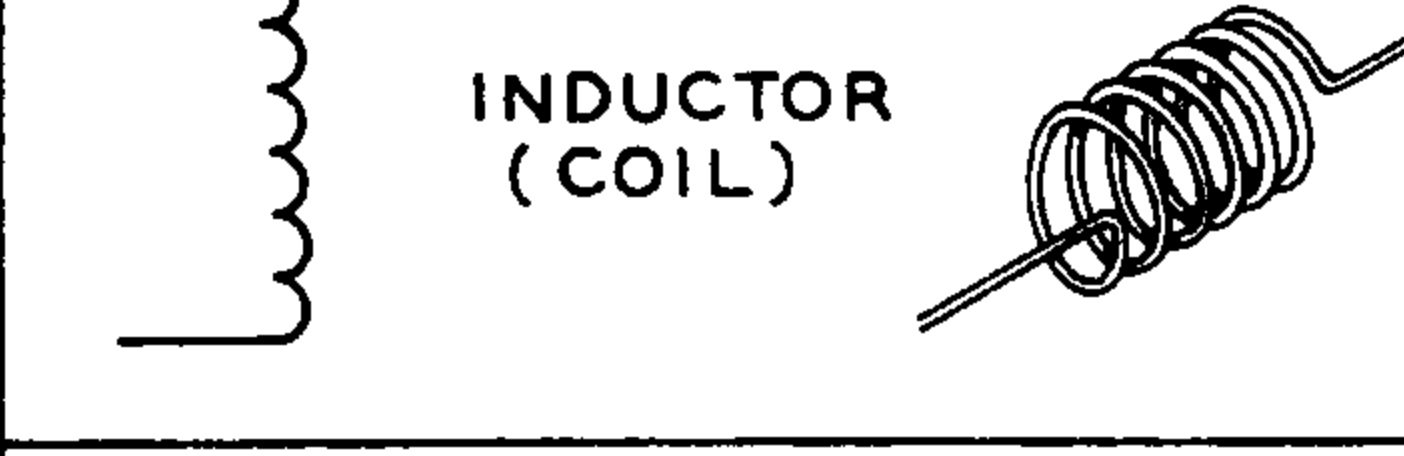
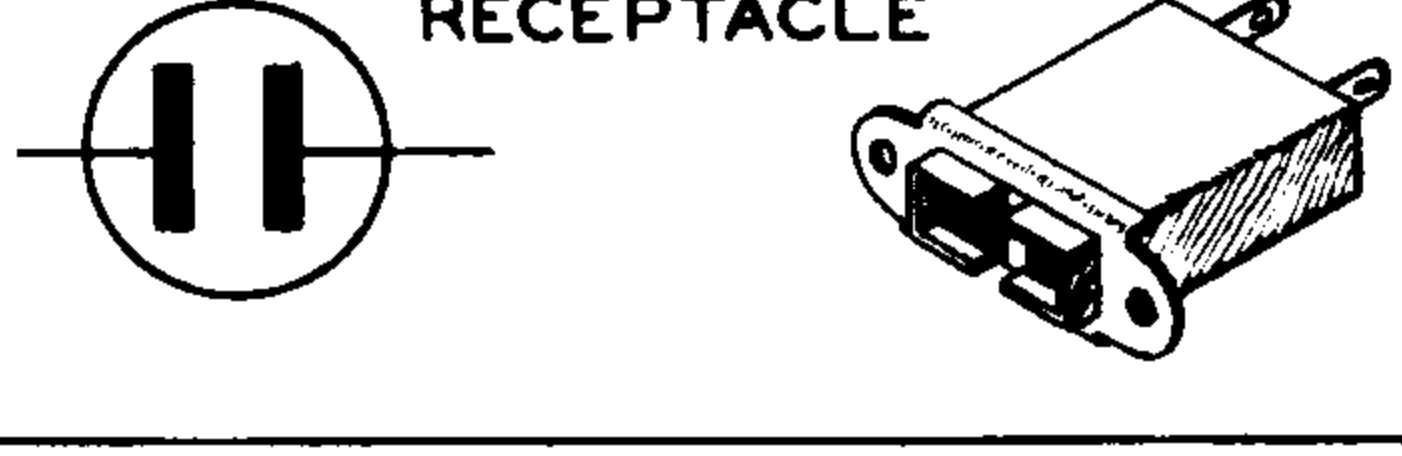
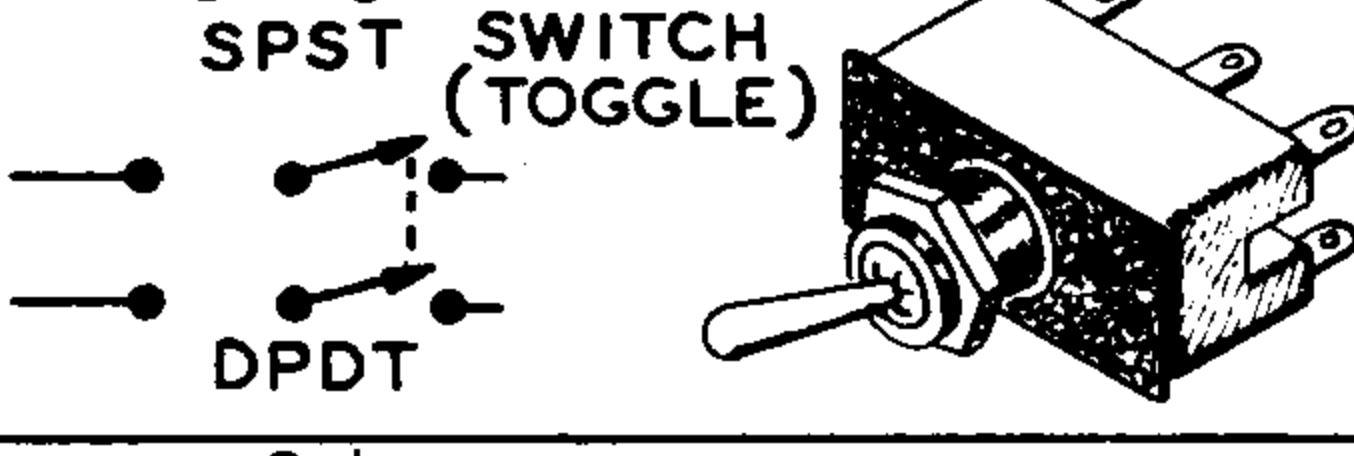
## TYPICAL COMPONENT TYPES

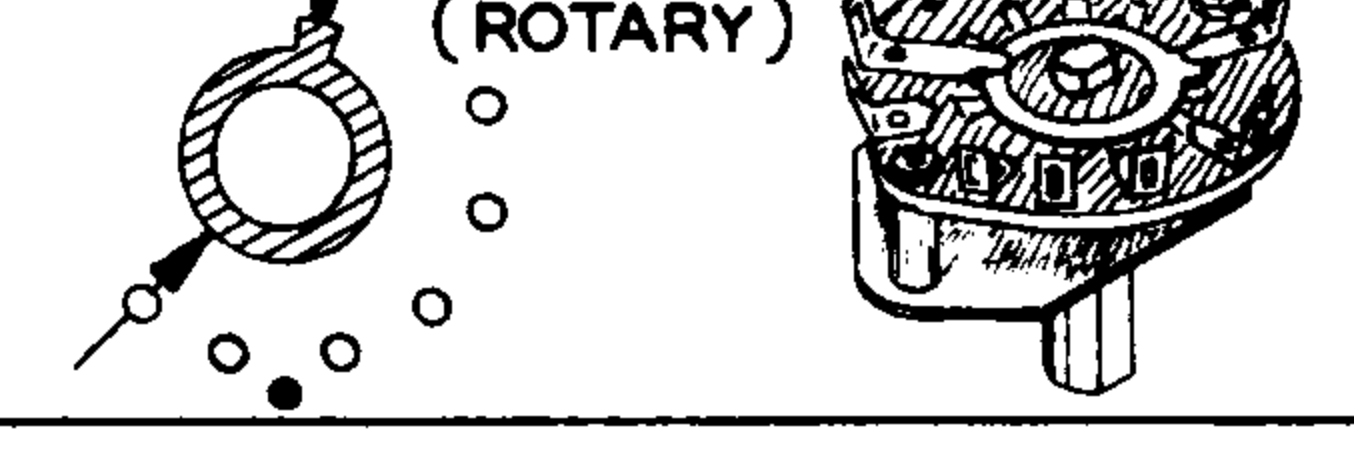
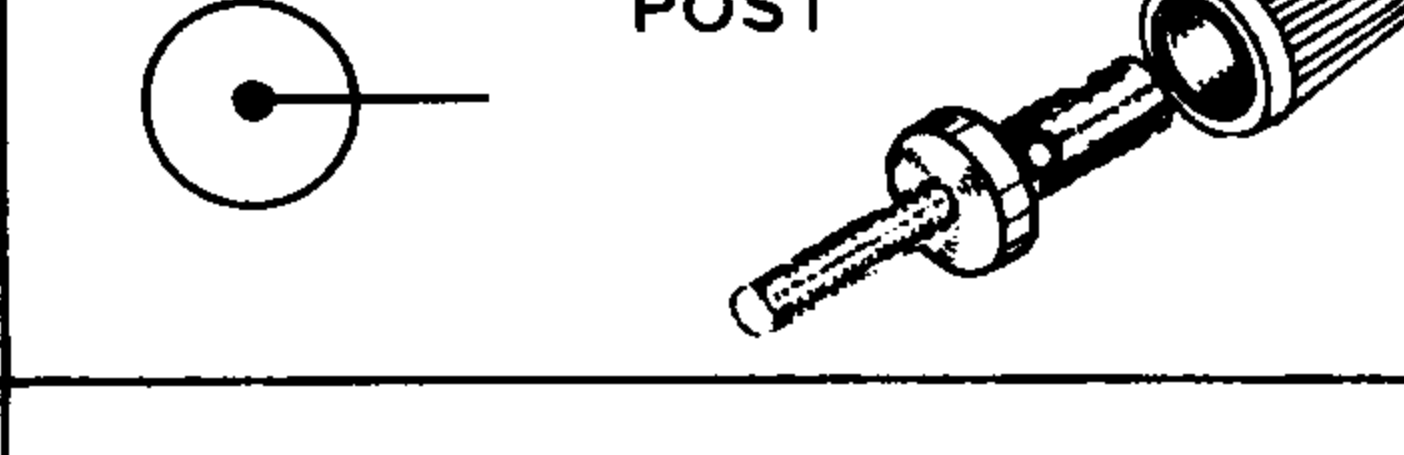
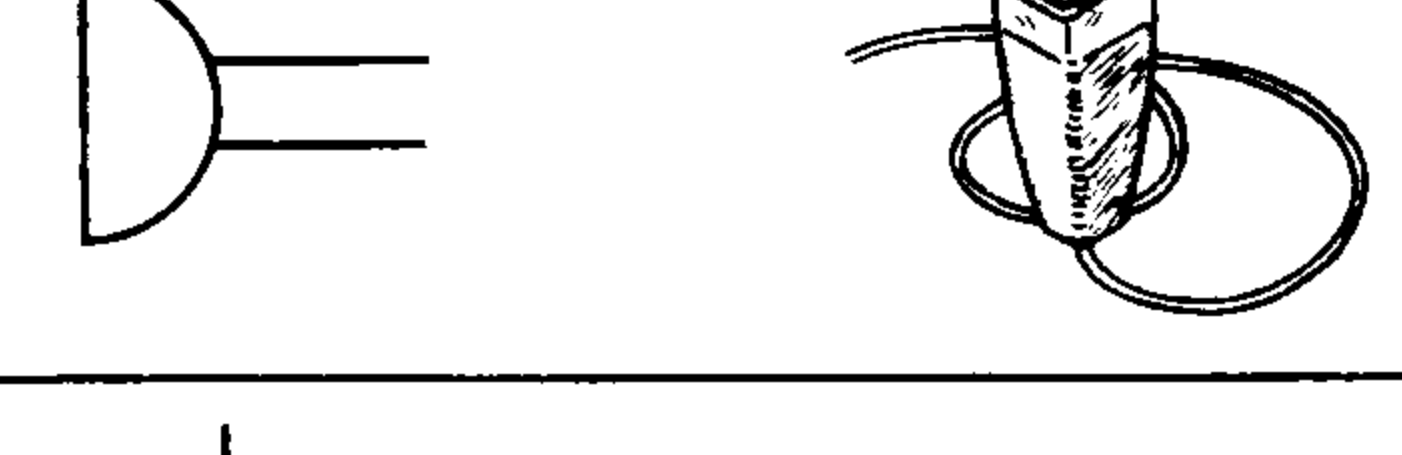
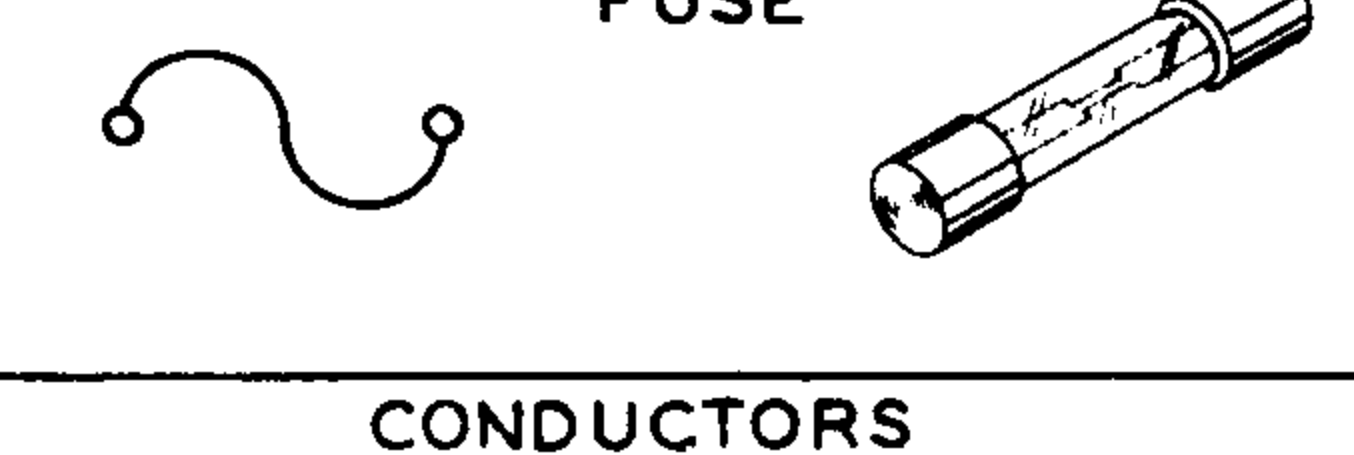
This chart is a guide to commonly used types of electronic components. The symbols and related illustrations

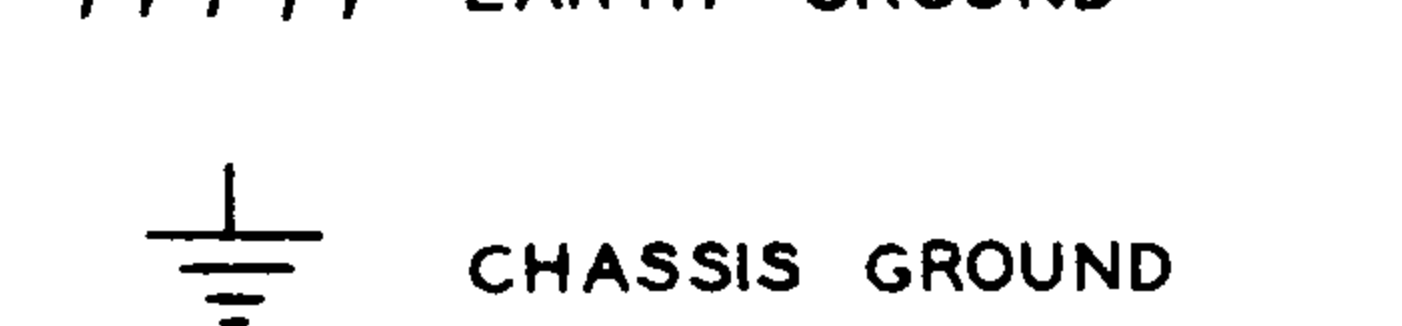
should prove helpful in identifying most parts and reading the schematic diagrams.

|                                                                                                                                                                                                                                             |                                                                                                                                                                                                                                                                                           |                                                                                                                                                   |
|---------------------------------------------------------------------------------------------------------------------------------------------------------------------------------------------------------------------------------------------|-------------------------------------------------------------------------------------------------------------------------------------------------------------------------------------------------------------------------------------------------------------------------------------------|---------------------------------------------------------------------------------------------------------------------------------------------------|
| <p style="text-align: center;"><b>RESISTOR</b></p>                                                                                                         | <p style="text-align: center;"><b>CAPACITOR</b></p>                                                                                                                                                     | <p style="text-align: center;"><b>TUBE</b></p>                 |
| <p style="text-align: center;"><b>POTENTIOMETER (CONTROL)</b></p>                                                                                          | <p style="text-align: center;"><b>ELECTROLYTIC CAPACITOR</b></p>                                                                                                                                        | <p style="text-align: center;"><b>TRANSISTOR</b></p>           |
| <p style="text-align: center;"><b>TRANSFORMER (IRON CORE)</b></p>                                                                                         | <p style="text-align: center;"><b>VARIABLE CAPACITOR</b></p>                                                                                                                                           | <p style="text-align: center;"><b>RECTIFIER (DIODE)</b></p>   |
| <p style="text-align: center;"><b>TRANSFORMER (ADJUSTABLE POWDERED IRON CORE) ARROW INDICATES DIRECTION OF CORE MOVEMENT TO INCREASE INDUCTANCE</b></p>  | <p style="text-align: center;"><b>BATTERY</b></p>                                                                                                                                                     | <p style="text-align: center;"><b>NEON BULB</b></p>          |
| <p style="text-align: center;"><b>TRANSFORMER (ADJUSTABLE CORE)</b></p>                                                                                  | <p style="text-align: center;"><b>PHONO JACK</b></p>                                                                                                                                                  | <p style="text-align: center;"><b>ILLUMINATING BULB</b></p>  |
| <p style="text-align: center;"><b>POWER TRANSFORMER</b></p>                                                                                              | <p style="text-align: center;"><b>PHONE JACK</b></p>                                                                                                                                                  | <p style="text-align: center;"><b>METER</b></p>              |
| <p style="text-align: center;"><b>INDUCTOR (COIL)</b></p>                                                                                                | <p style="text-align: center;"><b>RECEPTACLE</b></p>                                                                                                                                                  | <p style="text-align: center;"><b>SWITCH (TOGGLE)</b></p>    |
| <p style="text-align: center;"><b>PIEZOELECTRIC CRYSTAL</b></p>                                                                                          | <p style="text-align: center;"><b>SPEAKER</b></p>                                                                                                                                                     | <p style="text-align: center;"><b>SWITCH (ROTARY)</b></p>    |
| <p style="text-align: center;"><b>BINDING POST</b></p>                                                                                                   | <p style="text-align: center;"><b>MICROPHONE</b></p>                                                                                                                                                  | <p style="text-align: center;"><b>FUSE</b></p>               |
| <p style="text-align: center;"><b>ANTENNA</b></p>                                                                                                        | <p style="text-align: center;"><b>EARTH GROUND</b></p>  <p style="text-align: center;"><b>CHASSIS GROUND</b></p>  | <p style="text-align: center;"><b>CONDUCTORS</b></p>         |

Assembly  
and  
Operation  
of the



RF SIGNAL  
GENERATOR  
MODEL IG-102

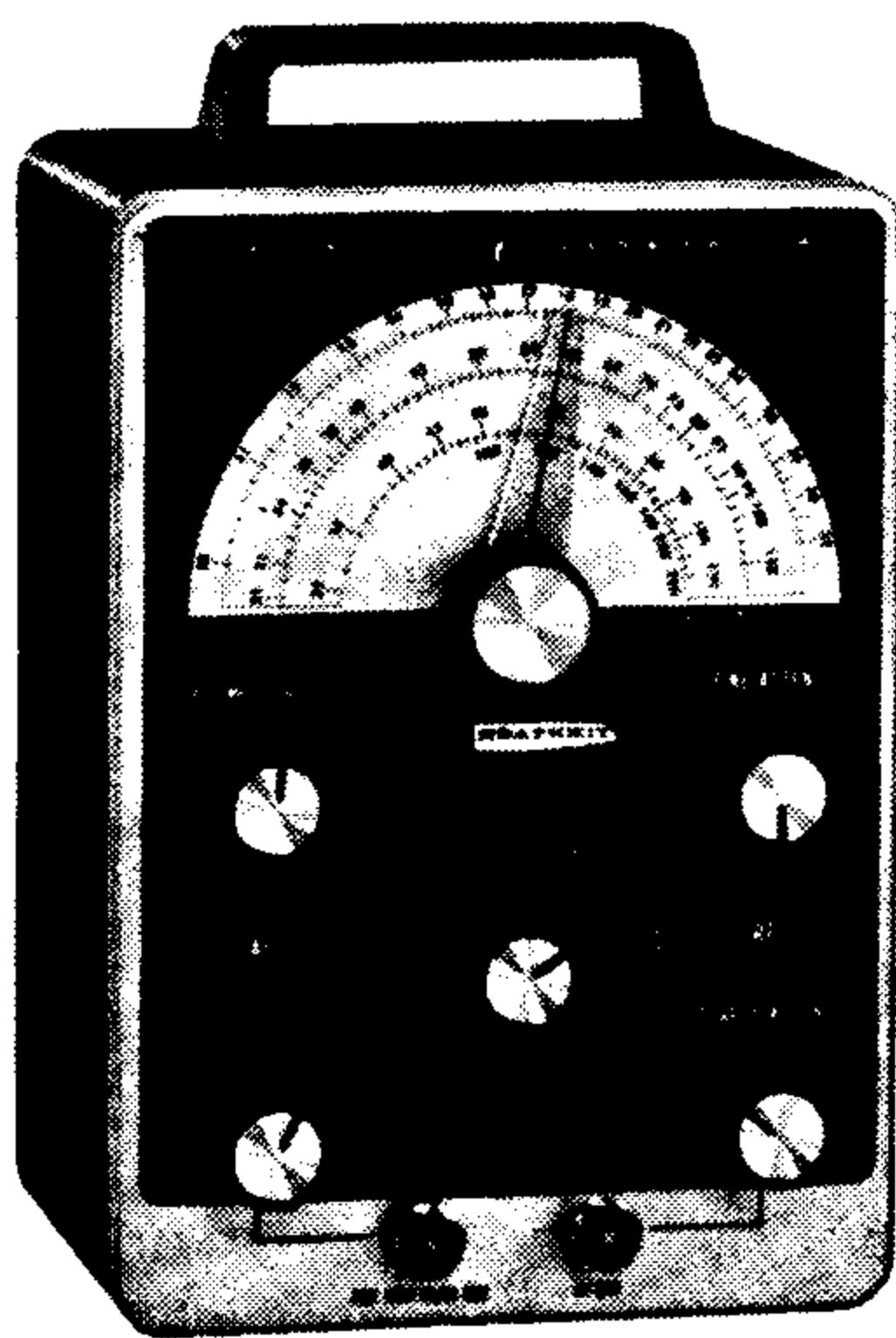

HEATH COMPANY  
BENTON HARBOR,  
MICHIGAN 49022

TABLE OF CONTENTS

|                                                   |    |
|---------------------------------------------------|----|
| Introduction . . . . .                            | 2  |
| Construction Notes. . . . .                       | 2  |
| Parts List. . . . .                               | 3  |
| Proper Soldering Techniques. . . . .              | 5  |
| Step-By-Step Procedure. . . . .                   | 6  |
| Step-By-Step Assembly -                           |    |
| Chassis Parts Mounting. . . . .                   | 7  |
| Front Panel Mounting. . . . .                     | 8  |
| Front Panel Parts Mounting<br>And Wiring. . . . . | 10 |
| Chassis Wiring. . . . .                           | 12 |
| Component Installation. . . . .                   | 14 |
| Knob And Tube Installation. . . . .               | 18 |
| Initial Test. . . . .                             | 19 |
| Calibration. . . . .                              | 20 |
| Final Assembly. . . . .                           | 22 |
| Operation. . . . .                                | 23 |
| Applications. . . . .                             | 24 |
| In Case Of Difficulty. . . . .                    | 27 |
| Factory Repair Service. . . . .                   | 27 |
| Troubleshooting Chart. . . . .                    | 28 |
| Specifications. . . . .                           | 30 |
| Circuit Description. . . . .                      | 31 |
| Replacement Parts Price List. . . . .             | 32 |
| Schematic. . . . (fold-out from page). . . .      | 33 |

## INTRODUCTION

The Heathkit Model IG-102 RF Signal Generator is an accurate and stable source of modulated or unmodulated RF (radio frequency) signals. Six over-lapping bands provide a wide range of frequencies for use in the AM, FM, TV, LW, and SW broadcast bands.

The RF frequency is indicated on a large dial scale that is accurate and easy to read. Switch-type and continuously variable attenuators are used to obtain output signal levels that are suitable for most applications.

A built-in audio oscillator provides modulation for the RF signal, and serves as a convenient source of audio signal. The RF may also be modulated by an external audio signal.

To insure greater accuracy of the RF frequencies, the bandswitch and coil assembly has been assembled and adjusted to precision standards at the factory. The completed Signal Generator can be calibrated without the need of expensive calibration equipment.

## CONSTRUCTION NOTES

This manual is supplied to assist you in every way to complete your kit with the least possible chance for error. The arrangement shown is the result of extensive experimentation and trial. If followed carefully, the result will be highly stable and dependable performance. We suggest that you retain the manual in your files for future reference, both in the use of the equipment and for its maintenance.

**UNPACK THE KIT CAREFULLY AND CHECK EACH PART AGAINST THE PARTS LIST.** In so doing, you will become acquainted with the parts. Refer to the information on the inside covers of the manual to help you identify the components. If some shortage or parts damage is found in checking the Parts List, please read the Replacements section and supply the information called for therein.

Resistors generally have a tolerance rating of 10% unless otherwise stated in the Parts List. Tolerances on capacitors are generally even greater. Limits of +100% and -20% are common for electrolytic capacitors.

We suggest that you do the following before work is started:

1. Lay out all parts so that they are readily available.
2. Provide yourself with good quality tools. Basic tool requirements consist of a screwdriver with a 1/4" blade; a small screwdriver with a 1/8" blade; long-nose pliers; wire cutters, preferably separate diagonal cutters; a penknife or a tool for stripping insulation from wires; and a soldering iron (or gun). A set of nut drivers, while not necessary, will aid extensively in construction of the kit.

Most kit builders find it helpful to separate the various parts into convenient categories. Muffin tins or molded egg cartons make convenient trays for small parts. Resistors and capacitors may be placed with their lead ends inserted in the edge of a piece of corrugated cardboard until they are needed. Values can be written on the cardboard next to each component. The illustration shows one method that may be used.

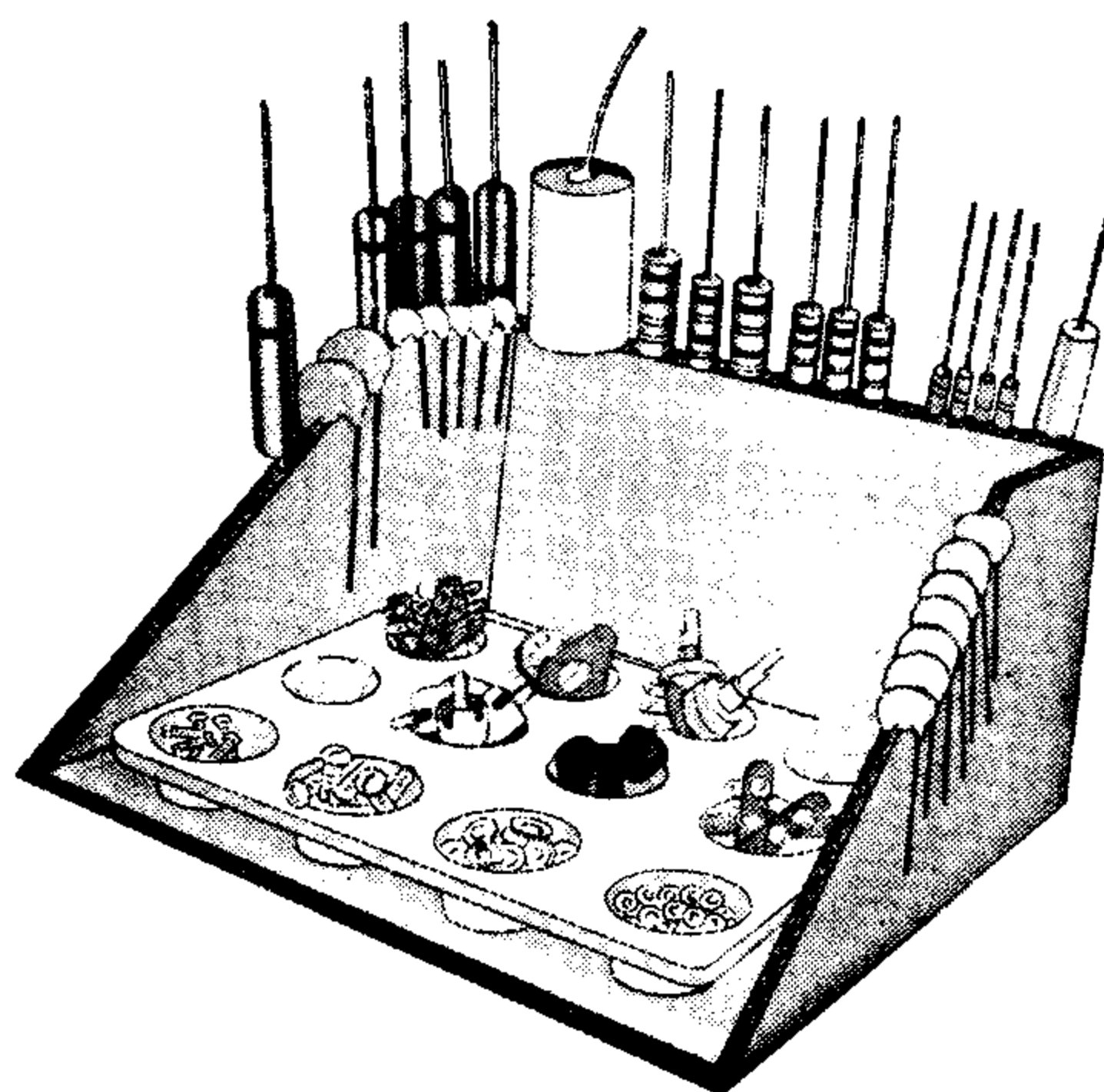

## PARTS LIST

The numbers in parentheses in the Parts List are keyed to the numbers on the Parts Pictorial (fold-out from Page 5) to aid in parts identification.

To order replacement parts, refer to the Replacement Parts Price List and use the Parts Order Form furnished with this kit.

| <u>PART No.</u>     | <u>PARTS Per Kit</u> | <u>DESCRIPTION</u>                   | <u>PART No.</u>                       | <u>PARTS Per Kit</u> | <u>DESCRIPTION</u>                                |
|---------------------|----------------------|--------------------------------------|---------------------------------------|----------------------|---------------------------------------------------|
| <b>RESISTORS</b>    |                      |                                      | <b>Tubular</b>                        |                      |                                                   |
| <b>1/2 Watt</b>     |                      |                                      | (4)23-39                              | 1                    | .0047 $\mu$ fd                                    |
| (1) 1-1             | 2                    | 47 $\Omega$ (yellow-violet-black)    | 23-50                                 | 1                    | .022 $\mu$ fd                                     |
| 1-48                | 1                    | 390 $\Omega$ (orange-white-brown)    | 23-59                                 | 1                    | .05 $\mu$ fd                                      |
| 1-7                 | 3                    | 680 $\Omega$ (blue-gray-brown)       | 23-28                                 | 1                    | .1 $\mu$ fd                                       |
| 1-16                | 1                    | 4700 $\Omega$ (yellow-violet-red)    | <b>Other</b>                          |                      |                                                   |
| 1-24                | 3                    | 33 K $\Omega$ (orange-orange-orange) | (5)28-1                               | 1                    | 2.2 $\mu$ $\mu$ f molded phenolic (red-red-white) |
| 1-47                | 1                    | 56 K $\Omega$ (green-blue-orange)    | (6)21-29                              | 1                    | 4.7 $\mu$ $\mu$ f N750 tubular ceramic            |
| 1-26                | 3                    | 100 K $\Omega$ (brown-black-yellow)  | (7)20-99                              | 1                    | 22 $\mu$ $\mu$ f mica                             |
|                     |                      |                                      | 20-101                                | 1                    | 47 $\mu$ $\mu$ f mica                             |
|                     |                      |                                      | (8)25-7                               | 1                    | 20-20 $\mu$ fd electrolytic                       |
| <b>1 Watt</b>       |                      |                                      | (9)31-8                               | 1                    | 1-10 $\mu$ $\mu$ f trimmer                        |
| (2) 1-23-1          | 1                    | 2200 $\Omega$ (red-red-red)          | (10)26-57                             | 1                    | Dual tuning                                       |
| <b>CAPACITORS</b>   |                      |                                      | <b>CONTROLS-TRANSFORMERS-SWITCHES</b> |                      |                                                   |
| <b>Disc Ceramic</b> |                      |                                      | (11)10-27                             | 1                    | 3000 $\Omega$ control                             |
| (3) 21-32           | 1                    | 47 $\mu$ $\mu$ f                     | 19-11                                 | 1                    | 100 K $\Omega$ control with SPST switch           |
| 21-14               | 2                    | .001 $\mu$ fd                        | 51-44                                 | 1                    | Oscillator transformer                            |
| 21-27               | 1                    | .005 $\mu$ fd                        | 54-92                                 | 1                    | Power transformer                                 |
| 21-16               | 4                    | .01 $\mu$ fd                         | (12)63-70                             | 1                    | 3-position rotary switch                          |
| 21-31               | 5                    | .02 $\mu$ fd                         | 63-211                                | 1                    | 2-position rotary switch                          |
|                     |                      |                                      | 163-2                                 | 1                    | Band switch and coil assembly                     |

| <u>PART No.</u>             | <u>PARTS Per Kit</u> | <u>DESCRIPTION</u>    | <u>PART No.</u>            | <u>PARTS Per Kit</u> | <u>DESCRIPTION</u>                        |
|-----------------------------|----------------------|-----------------------|----------------------------|----------------------|-------------------------------------------|
| <b>RECTIFIER-TUBES-LAMP</b> |                      |                       | <b>WIRE-CABLE-SLEEVING</b> |                      |                                           |
| (13)57-27                   | 1                    | Silicon diode         | 89-1                       | 1                    | Line cord                                 |
| 411-24                      | 1                    | 12AT7 tube            | 340-2                      | 1                    | Bare wire                                 |
| 411-68                      | 1                    | 6AN8 tube             | 344-59                     | 1                    | Hookup wire                               |
| 412-1                       | 1                    | #47 lamp              | 343-2                      | 1                    | Coaxial cable RG-58A/U                    |
| <b>TERMINAL STRIPS</b>      |                      |                       | 347-3                      | 1                    | 2-lead shielded cable                     |
| (14)431-10                  | 2                    | 3-lug terminal strip  | 346-1                      | 1                    | Sleeving                                  |
| 431-40                      | 2                    | 4-lug terminal strip  | <b>METAL PARTS</b>         |                      |                                           |
| 431-11                      | 1                    | 5-lug terminal strip  | 90-253                     | 1                    | Cabinet                                   |
| <b>CONNECTORS-SOCKETS</b>   |                      |                       | 200-442                    | 1                    | Chassis                                   |
| (15)432-1                   | 1                    | Cable connector       | 203-180-2                  | 1                    | Front panel                               |
| (16)432-3                   | 2                    | Chassis connector     | <b>MISCELLANEOUS</b>       |                      |                                           |
| (17)434-77                  | 2                    | 9-pin tube socket     | (34)40-193                 | 1                    | Band F oscillator coil                    |
| 434-87                      | 1                    | Pilot lamp socket     | (35)73-1                   | 5                    | Rubber grommet                            |
| <b>HARDWARE</b>             |                      |                       | (36)75-71                  | 1                    | Line cord strain relief                   |
| (18)250-49                  | 4                    | 3-48 x 1/4" screw     | (37)100-10                 | 1                    | Dial pointer assembly                     |
| (19)250-7                   | 5                    | 6-32 x 3/16" screw    | (38)205-254                | 1                    | Alignment tool blade                      |
| (20)250-56                  | 13                   | 6-32 x 1/4" screw     | (39)207-4                  | 2                    | Cable clamp                               |
| (21)250-89                  | 4                    | 6-32 x 3/8" screw     | 211-15                     | 1                    | Handle                                    |
| (22)250-83                  | 2                    | #10 sheet metal screw | 260-1                      | 2                    | Alligator clip                            |
| (23)250-16                  | 1                    | 8-32 setscrew         | (40)413-4                  | 1                    | Pilot lamp jewel                          |
| (24)252-1                   | 4                    | 3-48 nut              | 462-187                    | 5                    | Pointer knob                              |
| (25)252-3                   | 15                   | 6-32 nut              | 462-140                    | 1                    | Large knob                                |
| (26)252-37                  | 1                    | 9/32-32 x 3/8" nut    | (41)490-1                  | 1                    | Coil alignment tool                       |
| (27)252-7                   | 5                    | Control nut           | (42)490-5                  | 1                    | Plastic nut starter                       |
| (28)252-22                  | 2                    | Speednut              | 597-260                    | 1                    | Parts Order Form                          |
| (29)254-1                   | 18                   | #6 lockwasher         | 391-34                     | 1                    | Blue and white label                      |
| (30)254-4                   | 7                    | Control lockwasher    |                            | 1                    | Manual (See front cover for part number.) |
| (31)253-10                  | 5                    | Control flat washer   |                            |                      | Solder                                    |
| (32)259-1                   | 7                    | #6 solder lug         |                            |                      |                                           |
| (33)259-10                  | 2                    | Control solder lug    |                            |                      |                                           |

## PROPER SOLDERING TECHNIQUES

Only a small percentage of customers find it necessary to return equipment for factory service. By far the largest portion of malfunctions in this equipment are due to poor or improper soldering.

If terminals are bright and clean and free of wax, frayed insulation and other foreign substances, no difficulty will be experienced in soldering. Correctly soldered connections are essential if the performance engineered into a kit is to be fully realized. If you are a beginner with no experience in soldering, a half hour's practice with some odd lengths of wire may be a worthwhile investment.

For most wiring, a 25 to 100 watt iron or its equivalent in a soldering gun is very satisfactory. A lower wattage iron than this may not heat the connection enough to flow the solder smoothly. Keep the iron tip clean by wiping it from time to time with a cloth.

### CHASSIS WIRING AND SOLDERING

1. Unless otherwise indicated, all wire used is the type with colored insulation (hookup wire). In preparing a length of hookup wire, 1/4" of insulation should be removed from each end unless directed otherwise in the assembly step.
2. To avoid breaking internal connections when stripping insulation from the leads of transformers or similar components, care should be taken not to pull directly on the lead. Instead, hold the lead with pliers while it is being stripped.
3. Leads on resistors, capacitors, and similar components are generally much longer than need be to make the required connections. In these cases, the leads should be cut to proper length before the part is installed. In general, the leads should be just long enough to reach their terminating points.

4. Wherever there is a possibility of bare leads shorting to other parts or to the chassis, the leads should be covered with insulating sleeving. Where the use of sleeving is specifically intended, the phrase "use sleeving" is included in the associated assembly step. In any case where there is the possibility of an unintentional short circuit, sleeving should be used. Extra sleeving is provided for this purpose.

5. Crimp or bend the lead (or leads) around the terminal to form a good joint without relying on solder for physical strength. If the lead is too large to allow bending or if the step states that it is not to be crimped, position it so that a good solder connection can still be made.

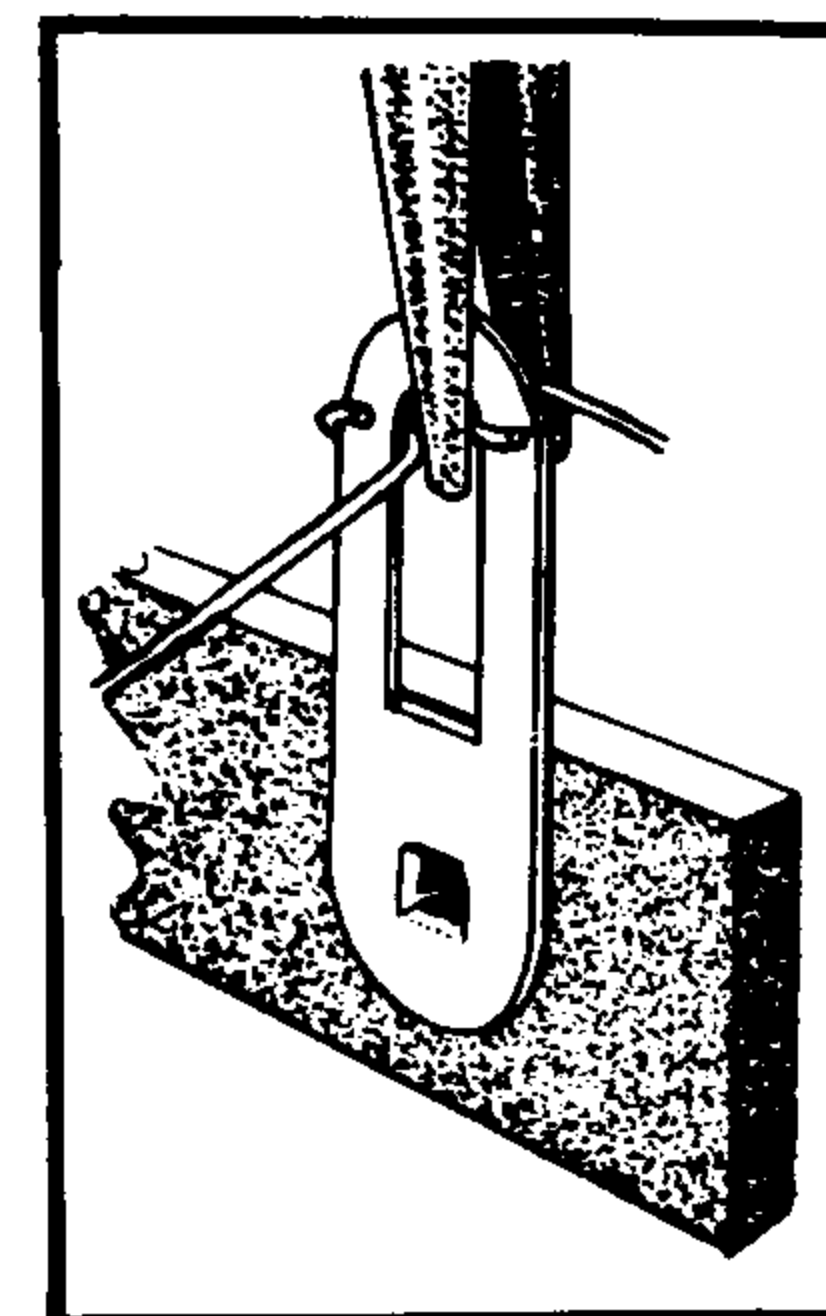

6. Position the work, if possible, so that gravity will help to keep the solder where you want it.

7. Place a flat side of the soldering iron tip against the joint to be soldered until it is heated sufficiently to melt the solder.

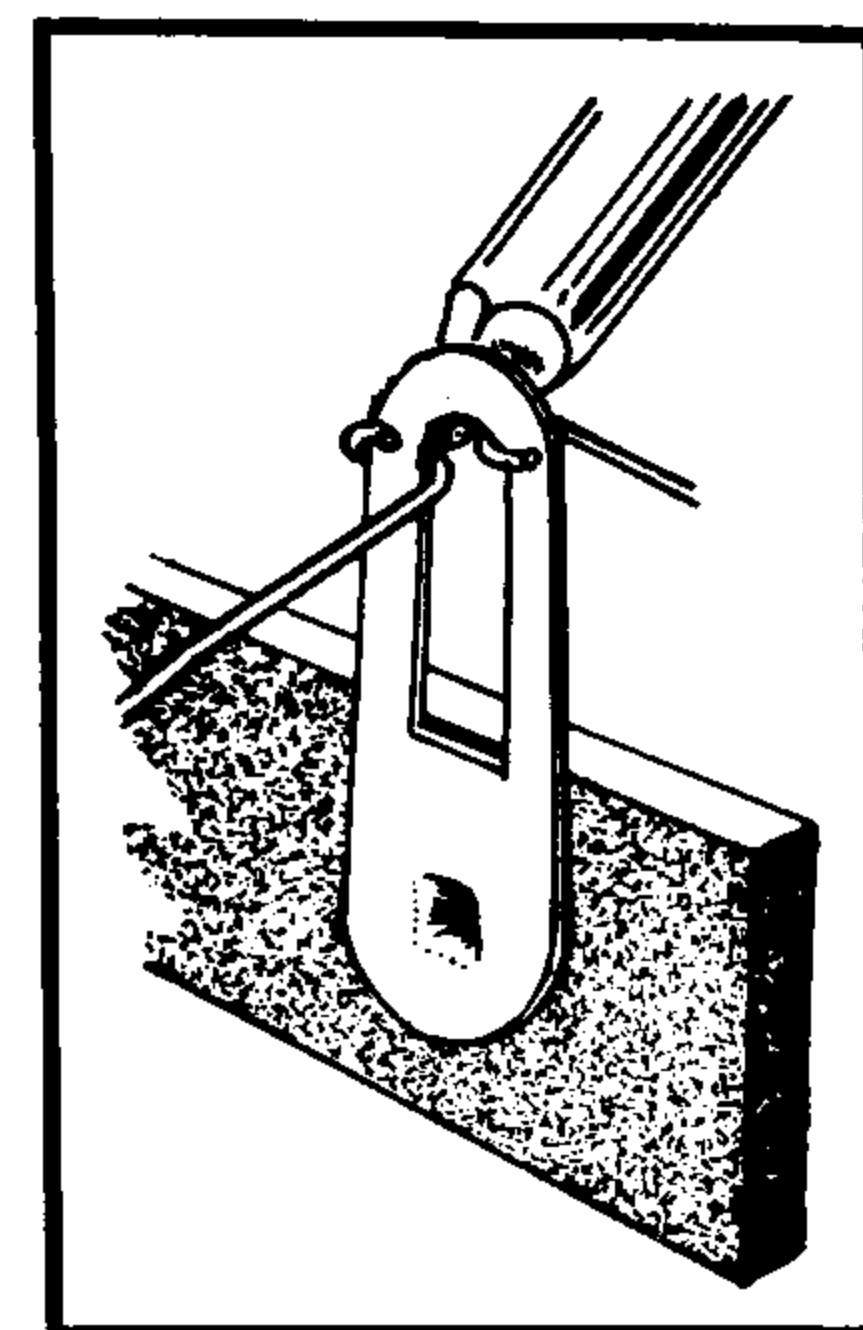

**PARTS PIC**

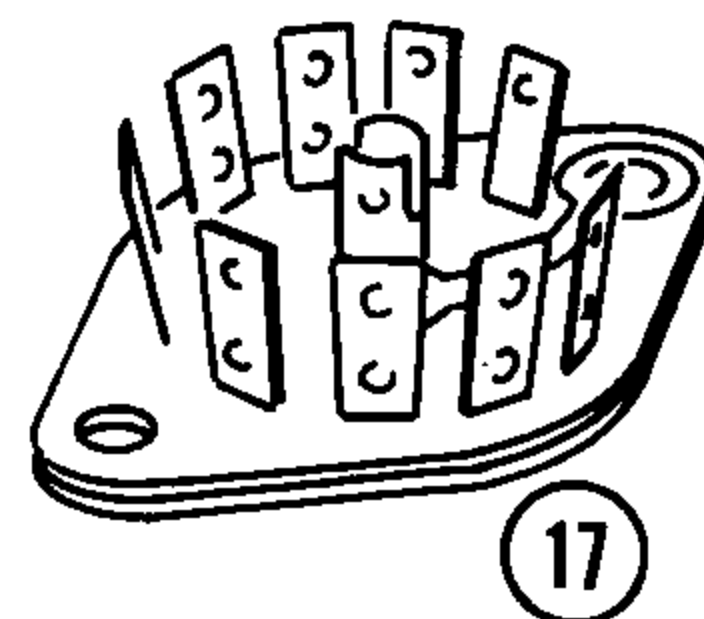
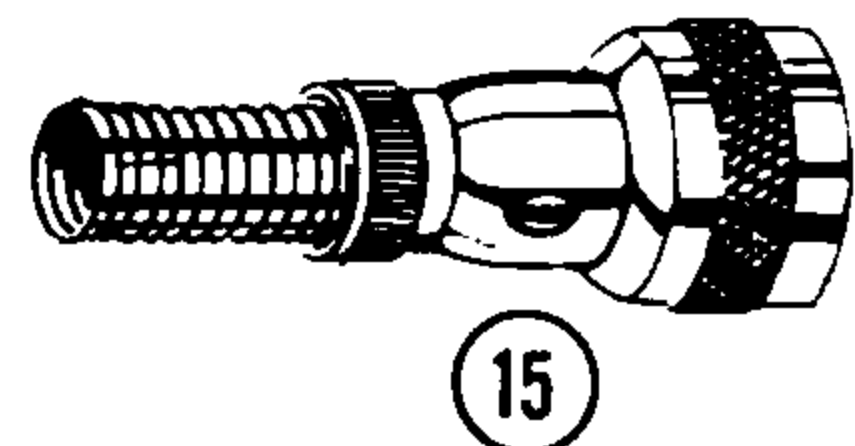
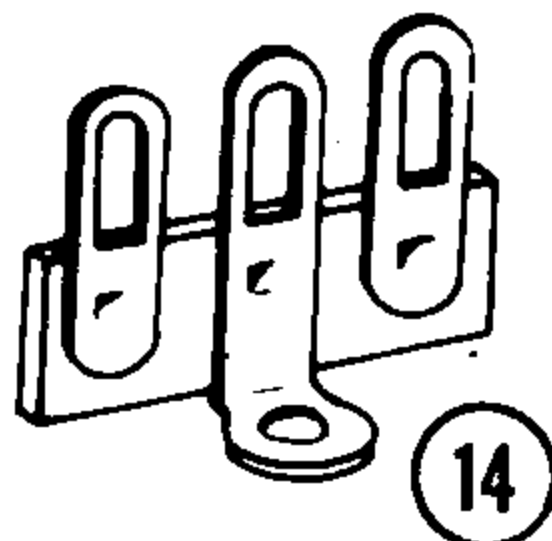
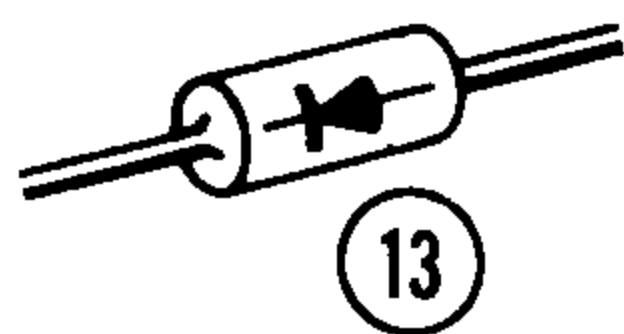
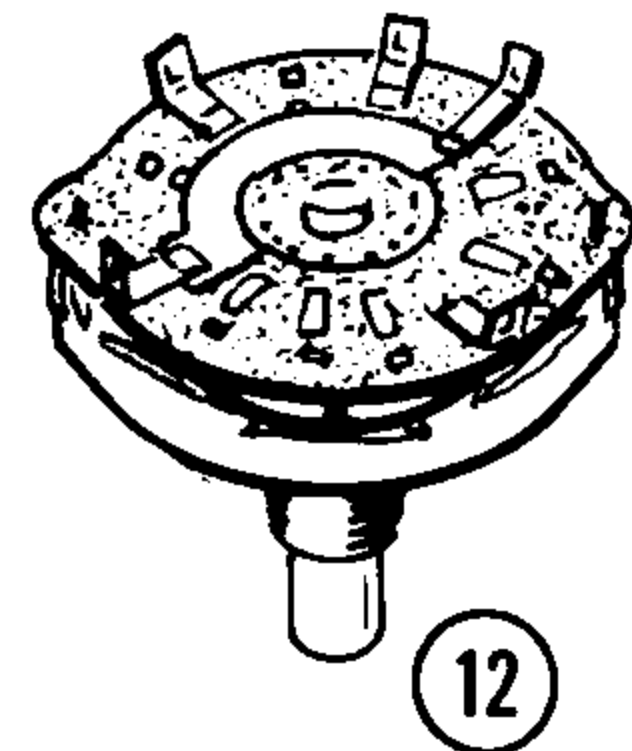
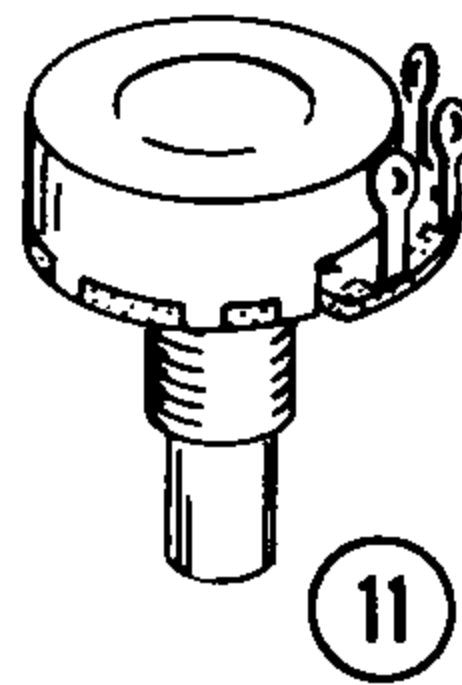
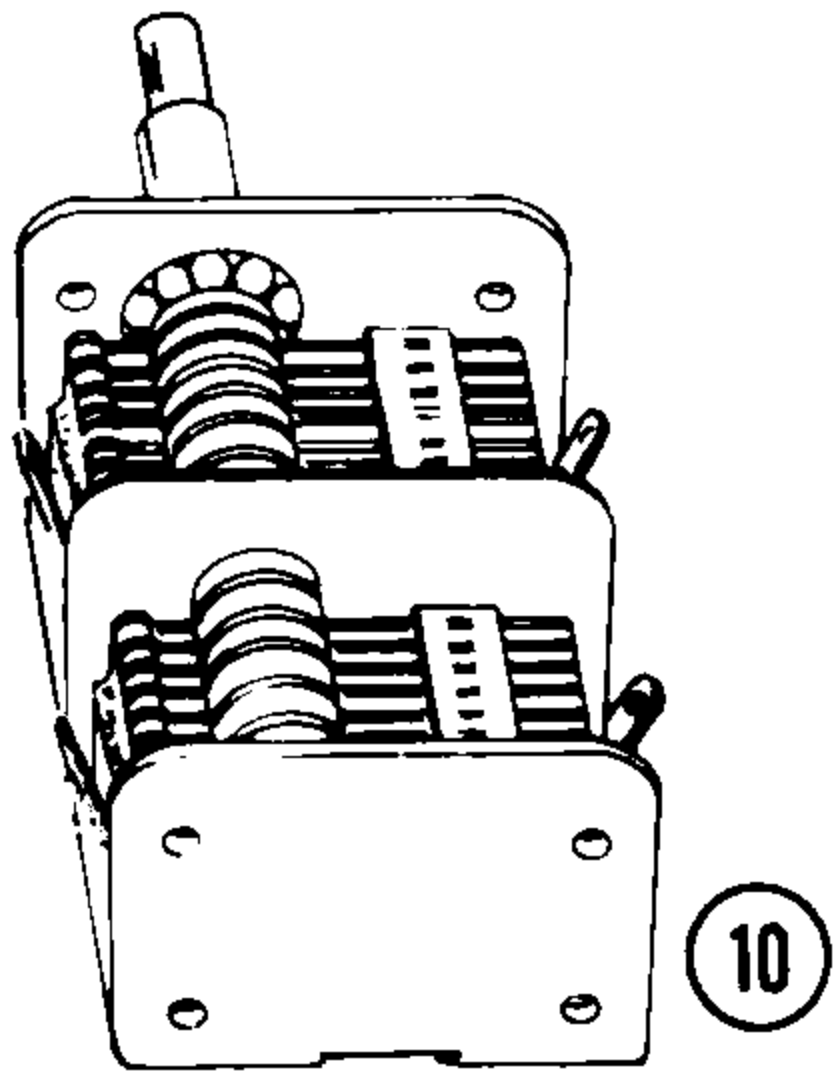
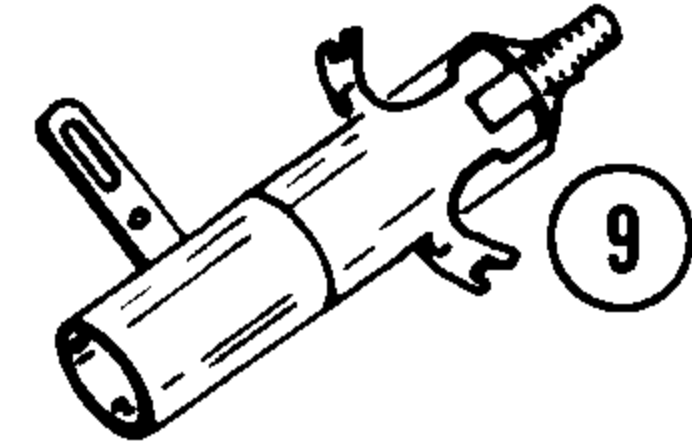
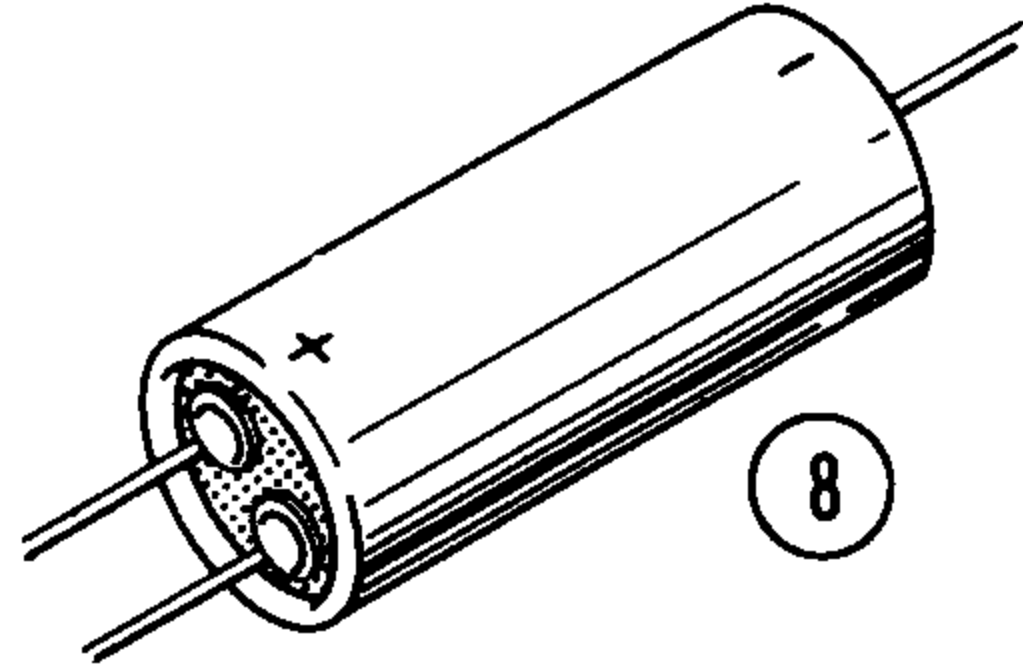
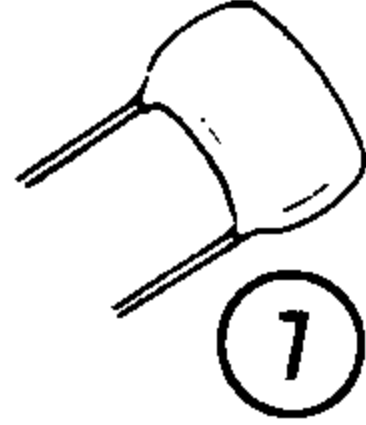
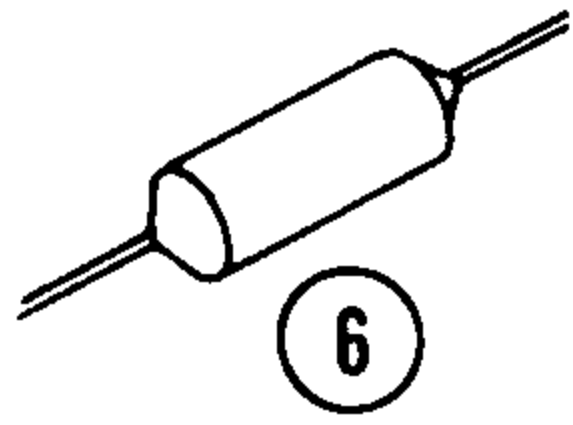
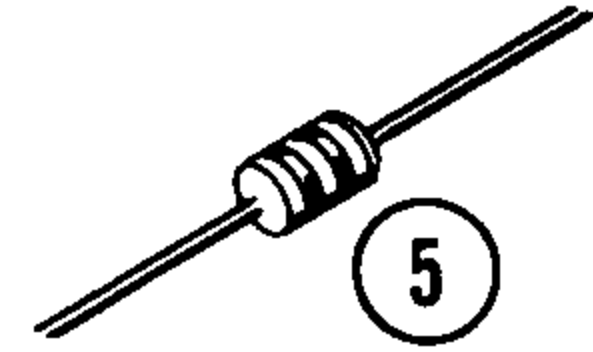
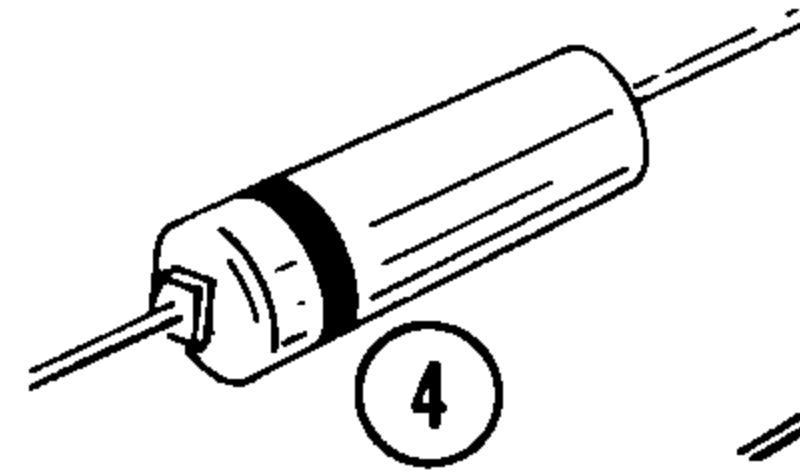
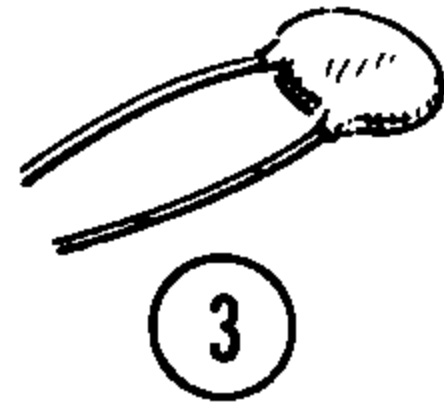
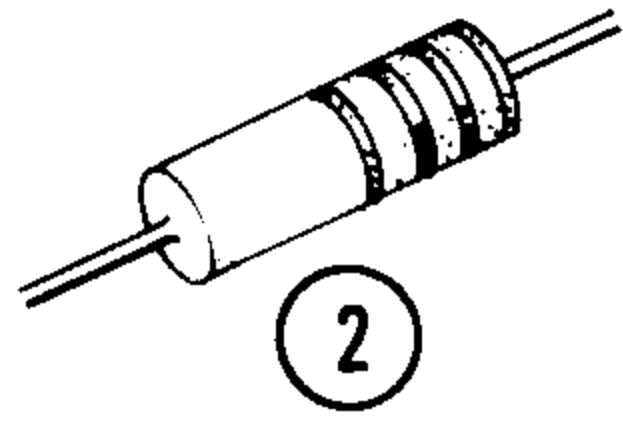
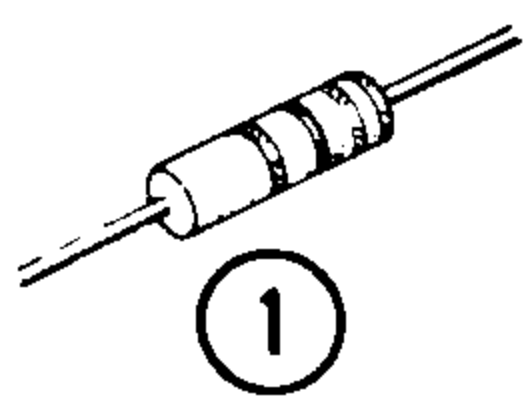



# TORIAL



18



19



20



21



22



23



24



25



26

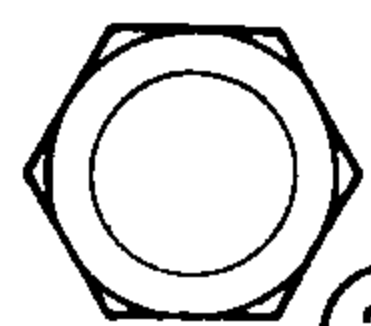

27



28



29

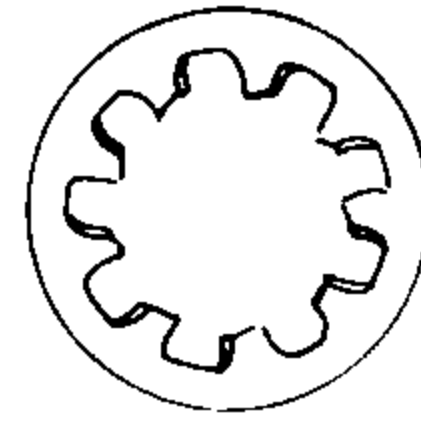

30

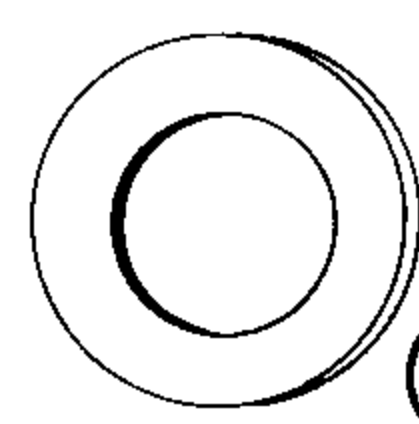

31



32

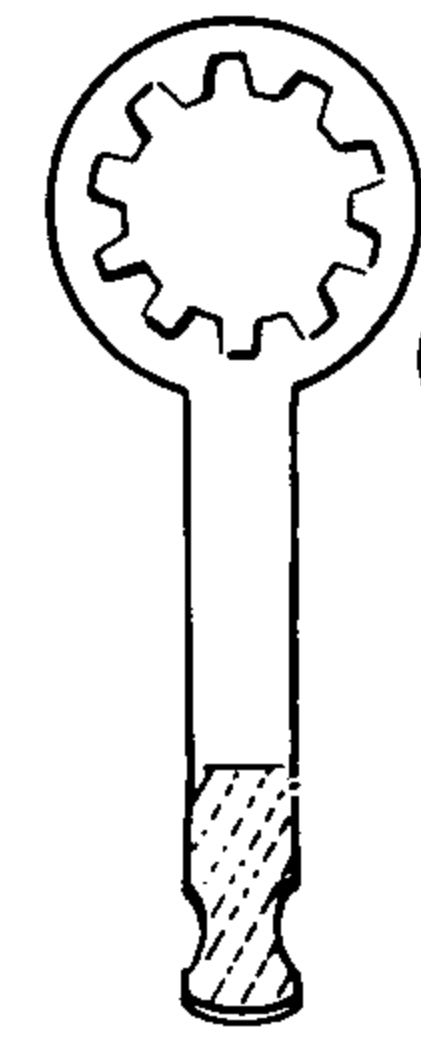

33

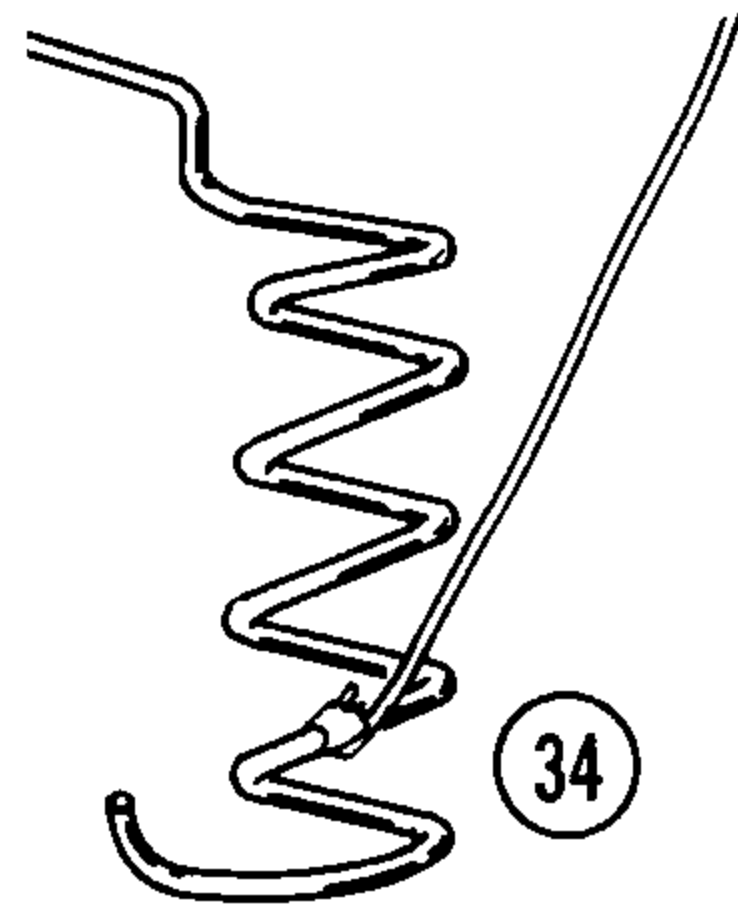

34



35

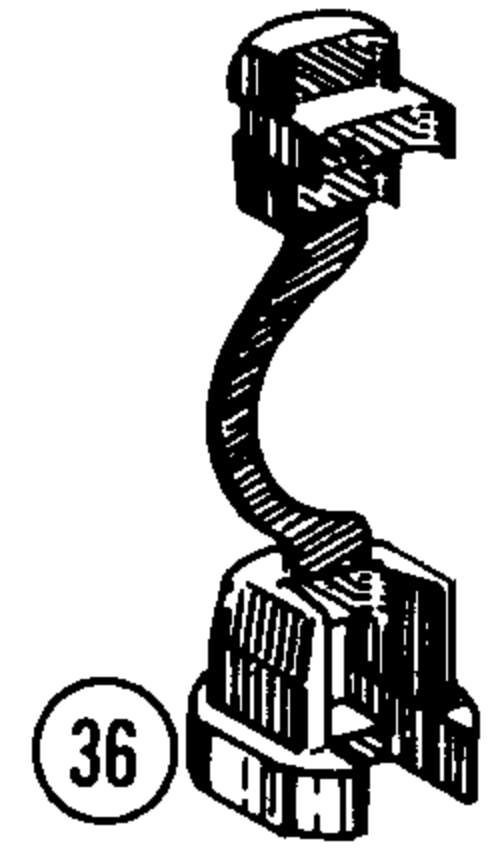

36

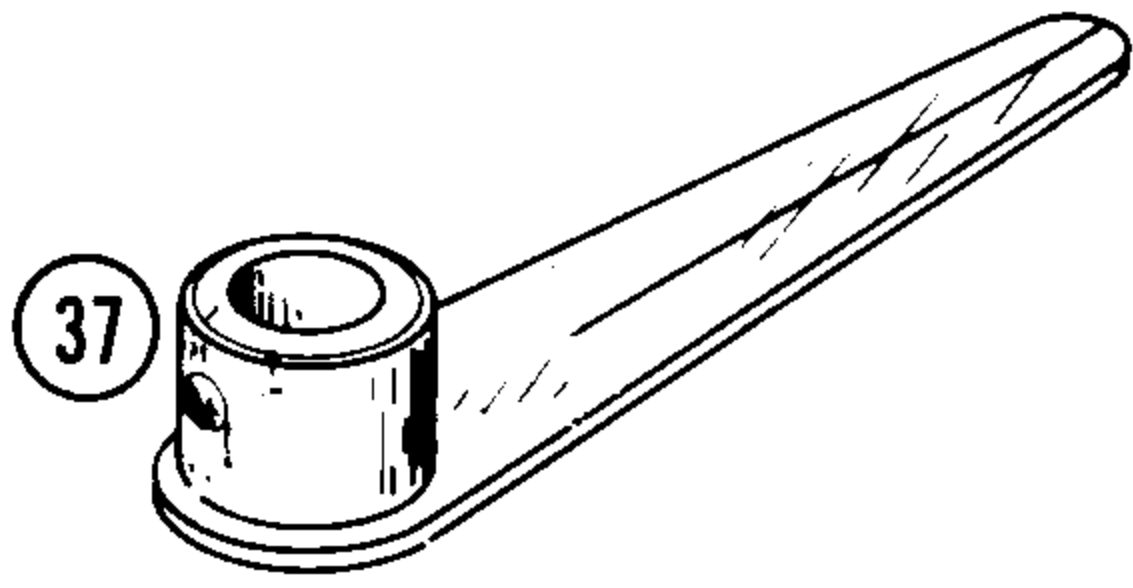

37

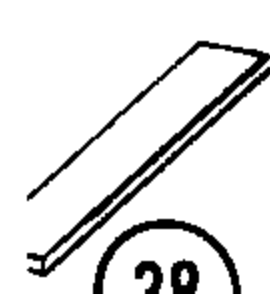

38

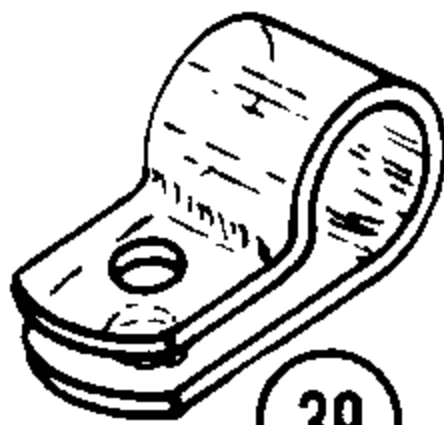

39



40

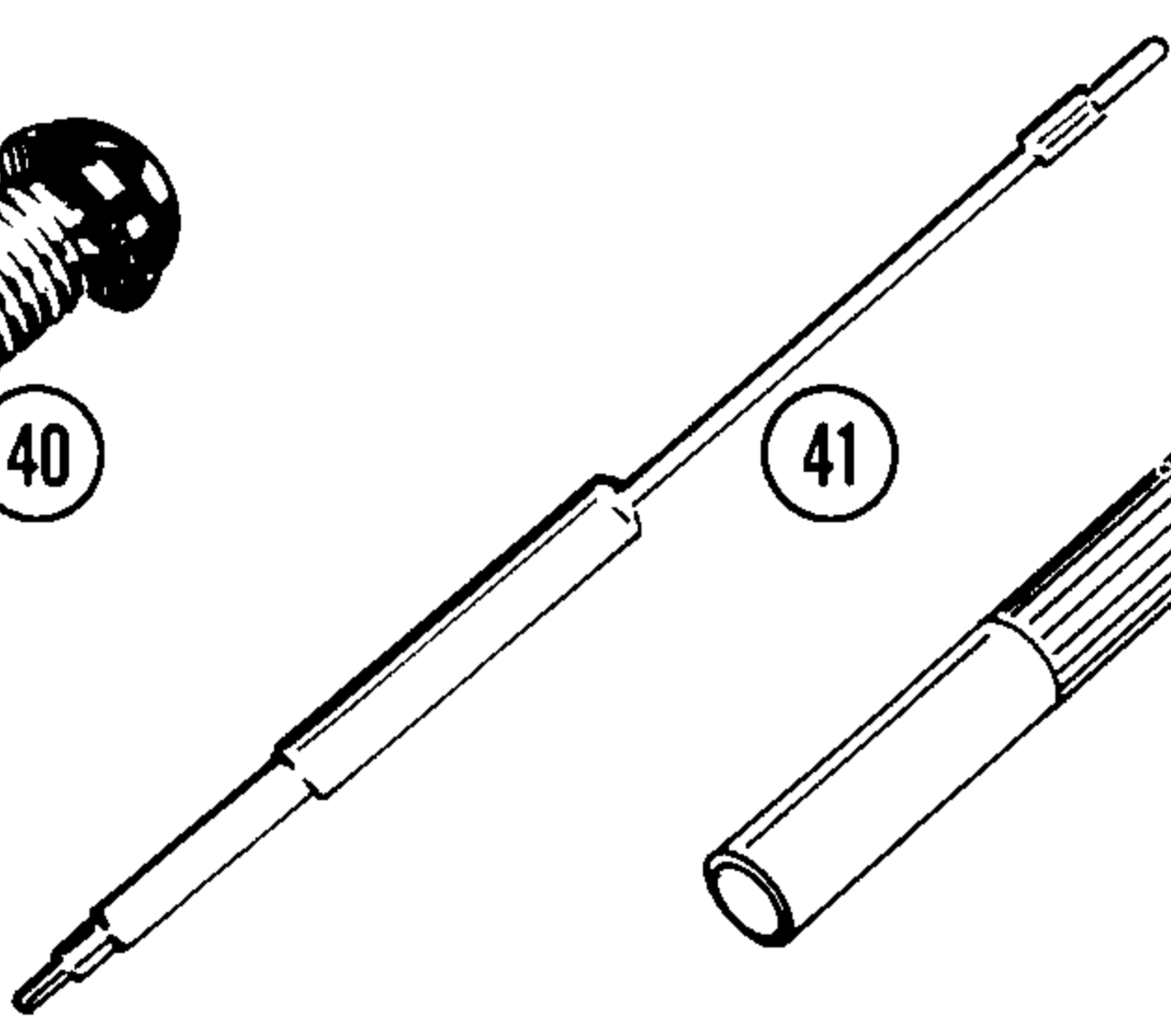

41

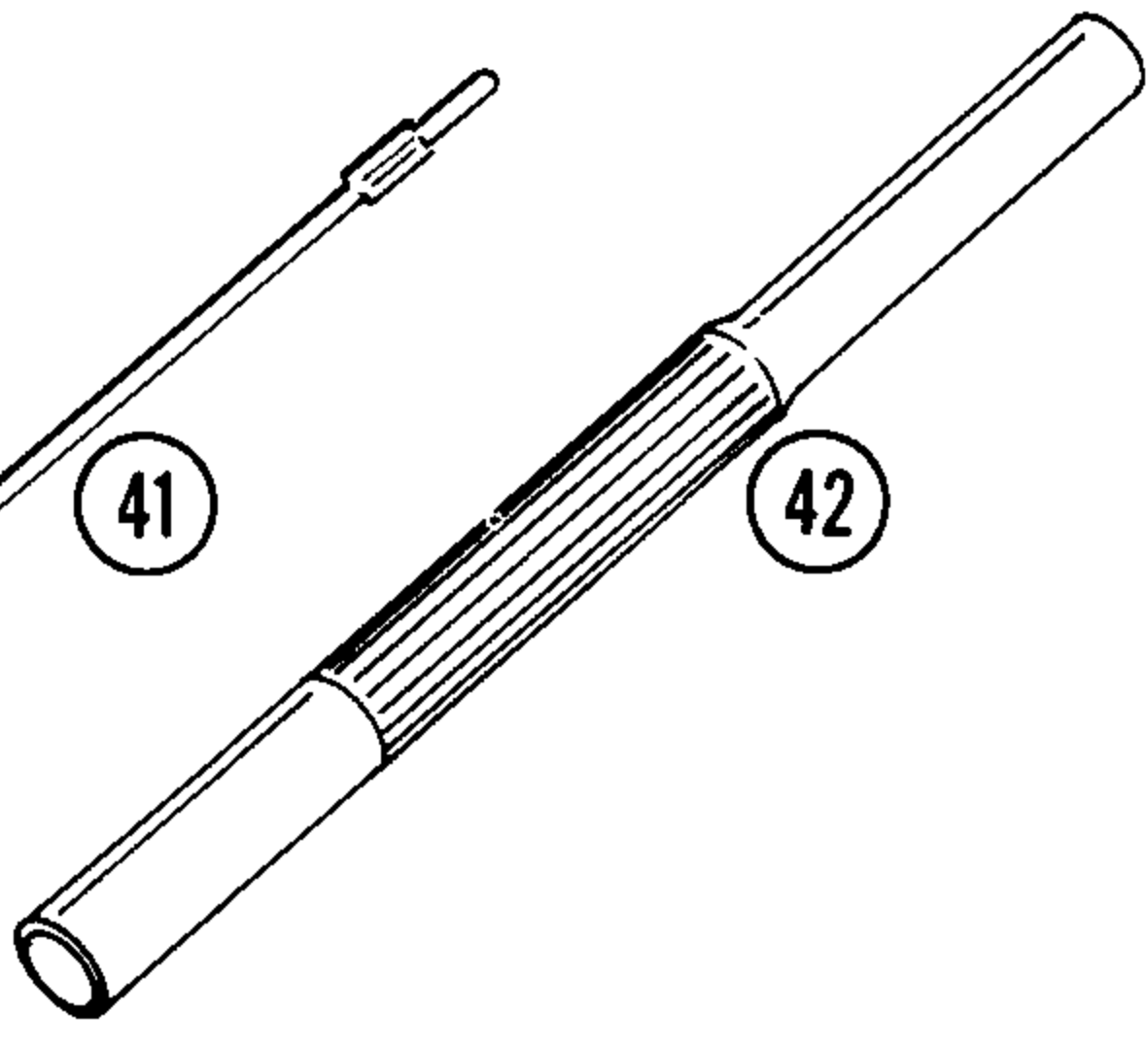

42

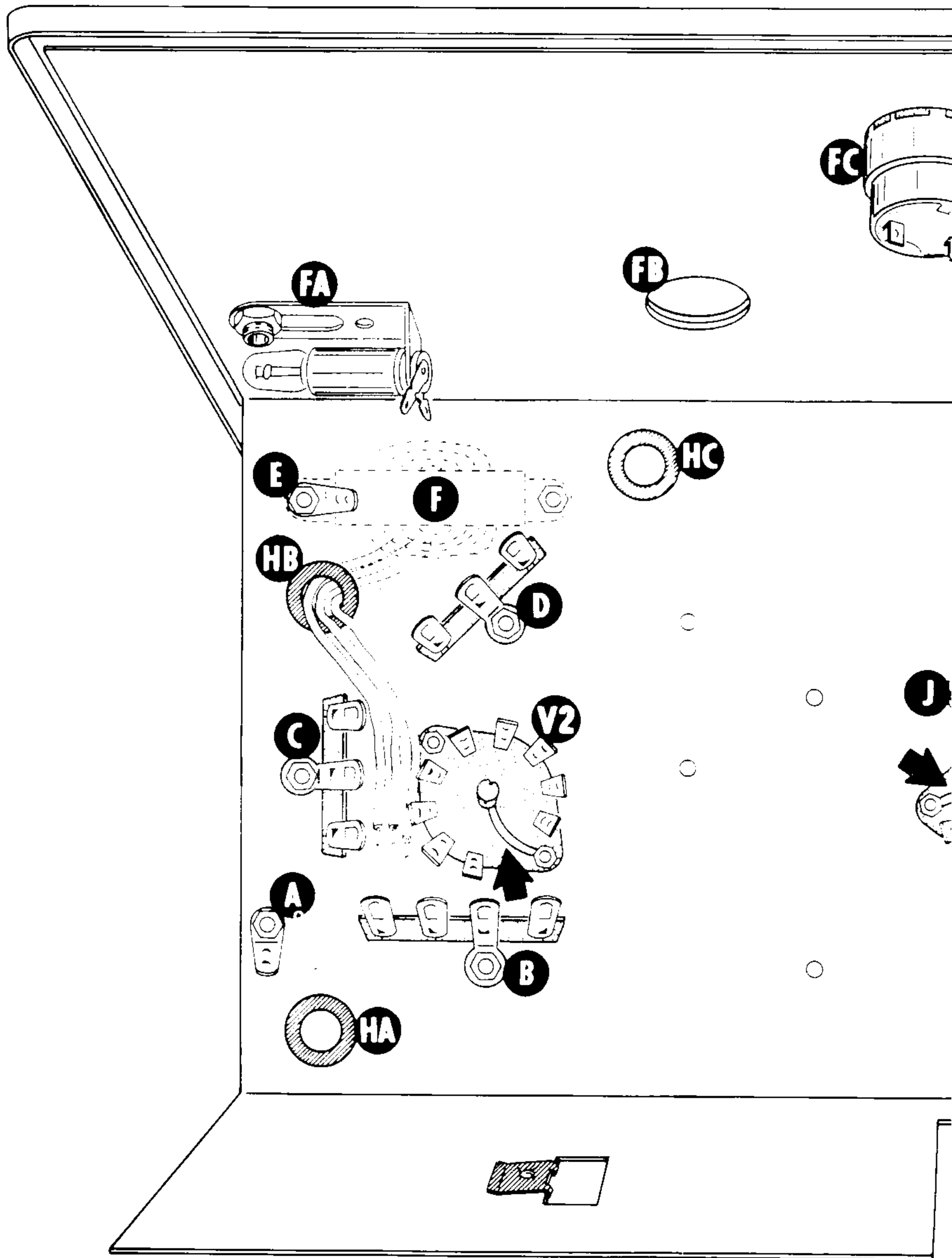

PICTORI

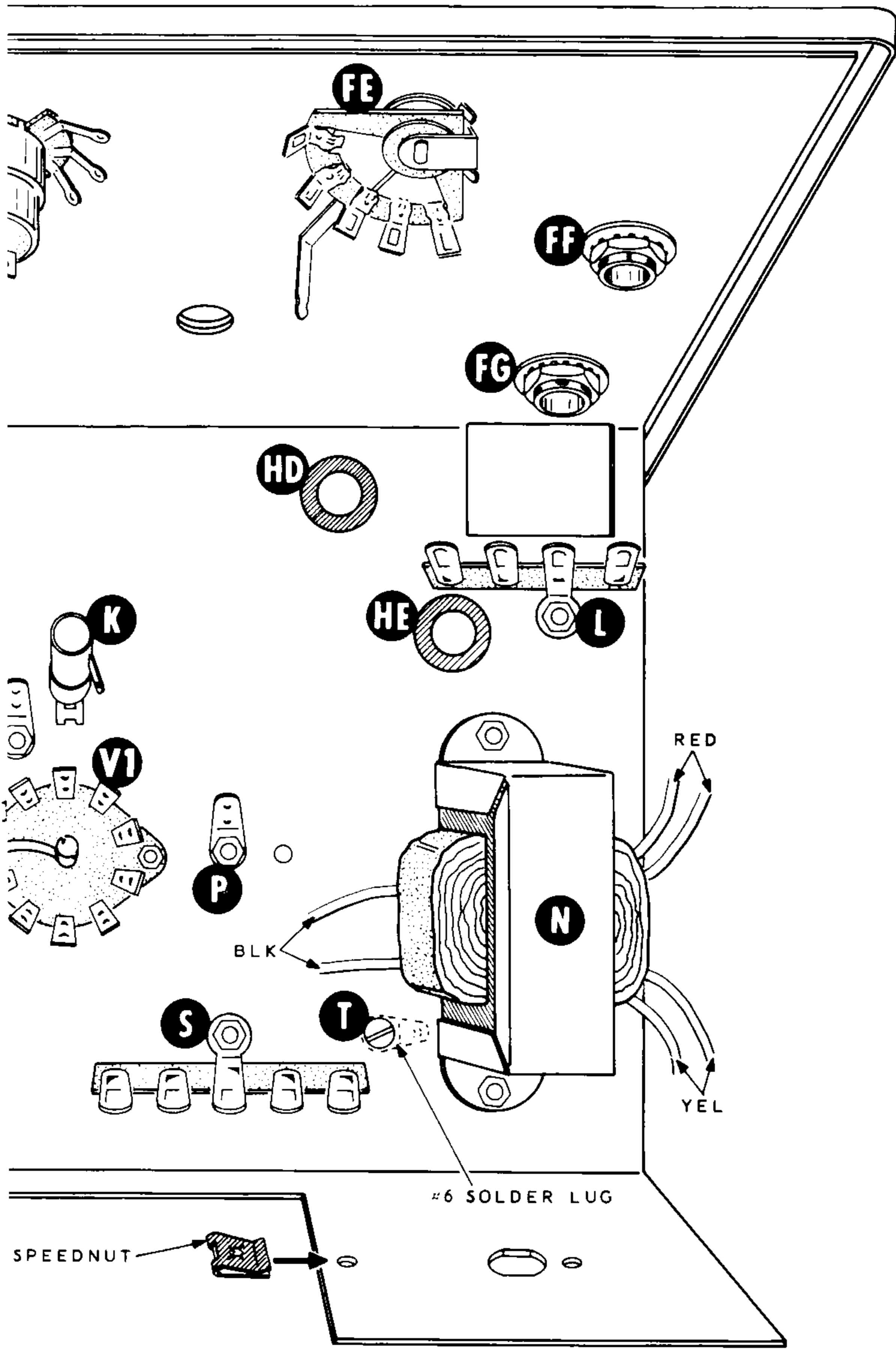

**AL 1**

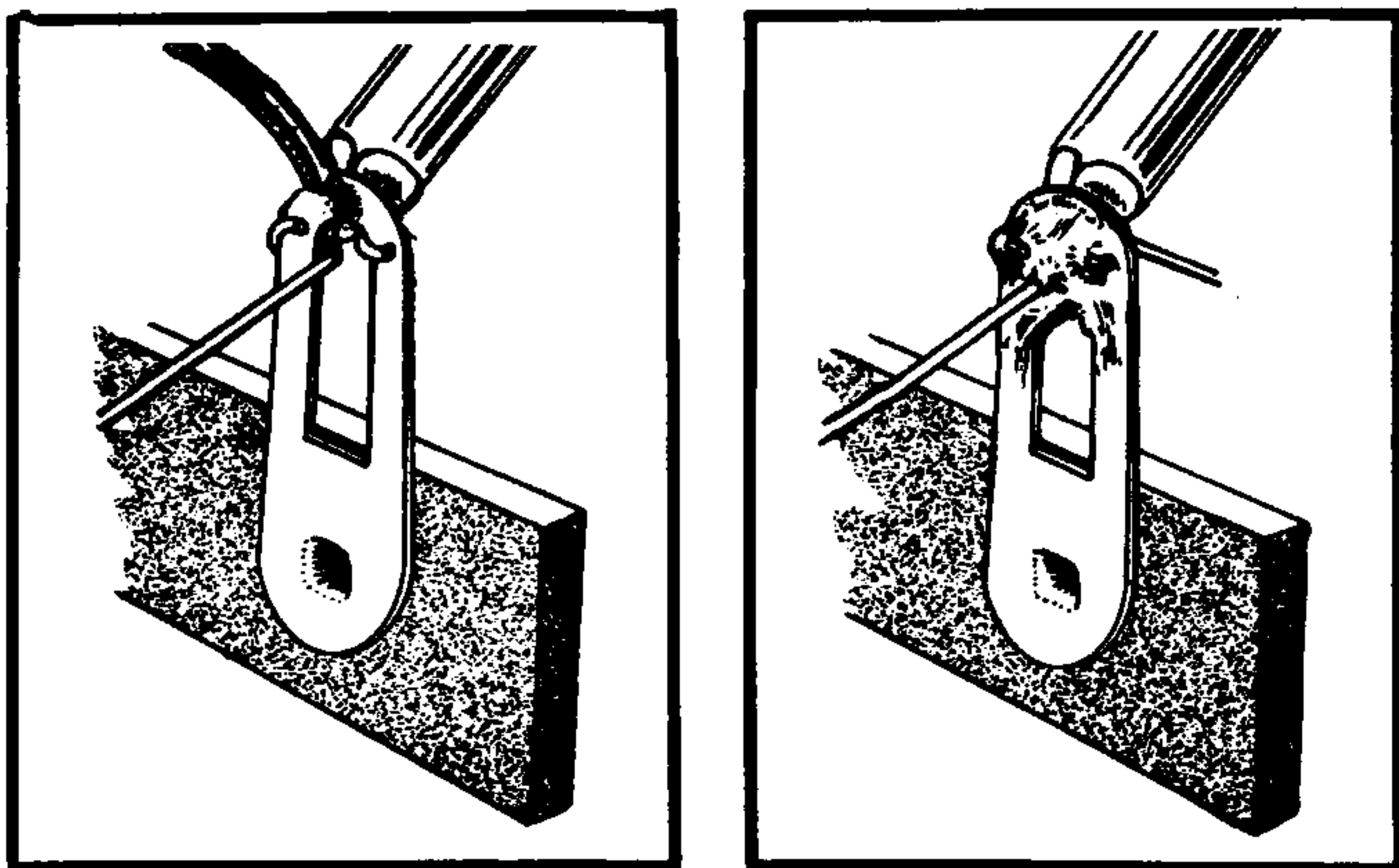

8. Then place the solder against the connection and it will immediately flow over the joint; use only enough solder to thoroughly wet the junction. It is usually not necessary to fill the entire hole in the terminal with solder.
9. Remove the solder and then the iron from the completed joint. Use care not to move the leads until the solder is solidified.

A poor or cold solder joint will usually look crystalline and have a grainy texture, or the solder will stand up in a blob and will not have adhered to the joint. Such joints should be reheated until the solder flows smoothly. In some cases, it may be necessary to add a little more solder to achieve a smooth, bright appearance.

ROSIN CORE SOLDER HAS BEEN SUPPLIED WITH THIS KIT. THIS TYPE OF SOLDER MUST BE USED FOR ALL SOLDERING IN THIS KIT. ALL GUARANTEES ARE VOIDED AND WE WILL NOT REPAIR OR SERVICE EQUIPMENT IN WHICH ACID CORE SOLDER OR PASTE FLUXES HAVE BEEN USED. IF ADDITIONAL SOLDER IS NEEDED, BE SURE TO PURCHASE ROSIN CORE (60:40 or 50:50 TIN-LEAD CONTENT) RADIO TYPE SOLDER.

## STEP-BY-STEP PROCEDURE

The following instructions are presented in a logical step-by-step sequence to enable you to complete your kit with the least possible confusion. Be sure to read each step all the way through before beginning the specified operation. Also read several steps ahead of the actual step being performed. This will familiarize you with the relationship of the subsequent operations. When the step is completed, check it off in the space provided. This is particularly important as it may prevent errors or omissions, especially if your work is interrupted. Some kit builders have also found it helpful to mark each wire and part in colored pencil on the Pictorial as it is added.

### ILLUSTRATIONS

The fold-out diagrams in this manual may be removed and attached to the wall above your working area; but because they are an integral part of the instructions, they should be returned to the manual after the kit is completed.

In general, the illustrations in this manual correspond to the actual configuration of the kit; however, in some instances the illustrations may be slightly distorted to facilitate clearly showing all of the parts.

### SOLDERING

The abbreviation "NS" indicates that a connection should not be soldered yet as other wires will be added. When the last wire is installed, the terminal should be soldered and the abbreviation "S" is used to indicate this. Note that a number will appear after each solder instruction. This number indicates the number of leads that are supposed to be connected to the terminal in point before it is soldered. For example, if the instruction reads, "Connect a wire to lug 1 (S-2)," it will be understood that there will be two wires connected to the terminal at the time it is soldered. (In cases where a wire passes through a terminal or lug and then connects to another point, it will count as two wires, one entering and one leaving the terminal.)

## STEP-BY-STEP ASSEMBLY

### CHASSIS PARTS MOUNTING

Refer to Pictorial 1 for the following steps.

- ( ) Locate the chassis and position it as shown.
- ( ) Install the five rubber grommets at HA, HB, HC, HD, and HE.
- ( ) Install the two speednuts on the rear flange of the chassis. Be sure the flat side of each speednut is on the outside of the chassis as shown.

NOTE: A plastic nut starter is provided for your convenience. Refer to the inside front cover of this Manual for information on its use.

- ( ) Refer to Detail 1A and mount the two 9-pin tube sockets at V1 and V2. Use 3-48 x 1/4" screws and 3-48 nuts. Position the blank space of the tube sockets as shown by the arrows on Pictorial 1.

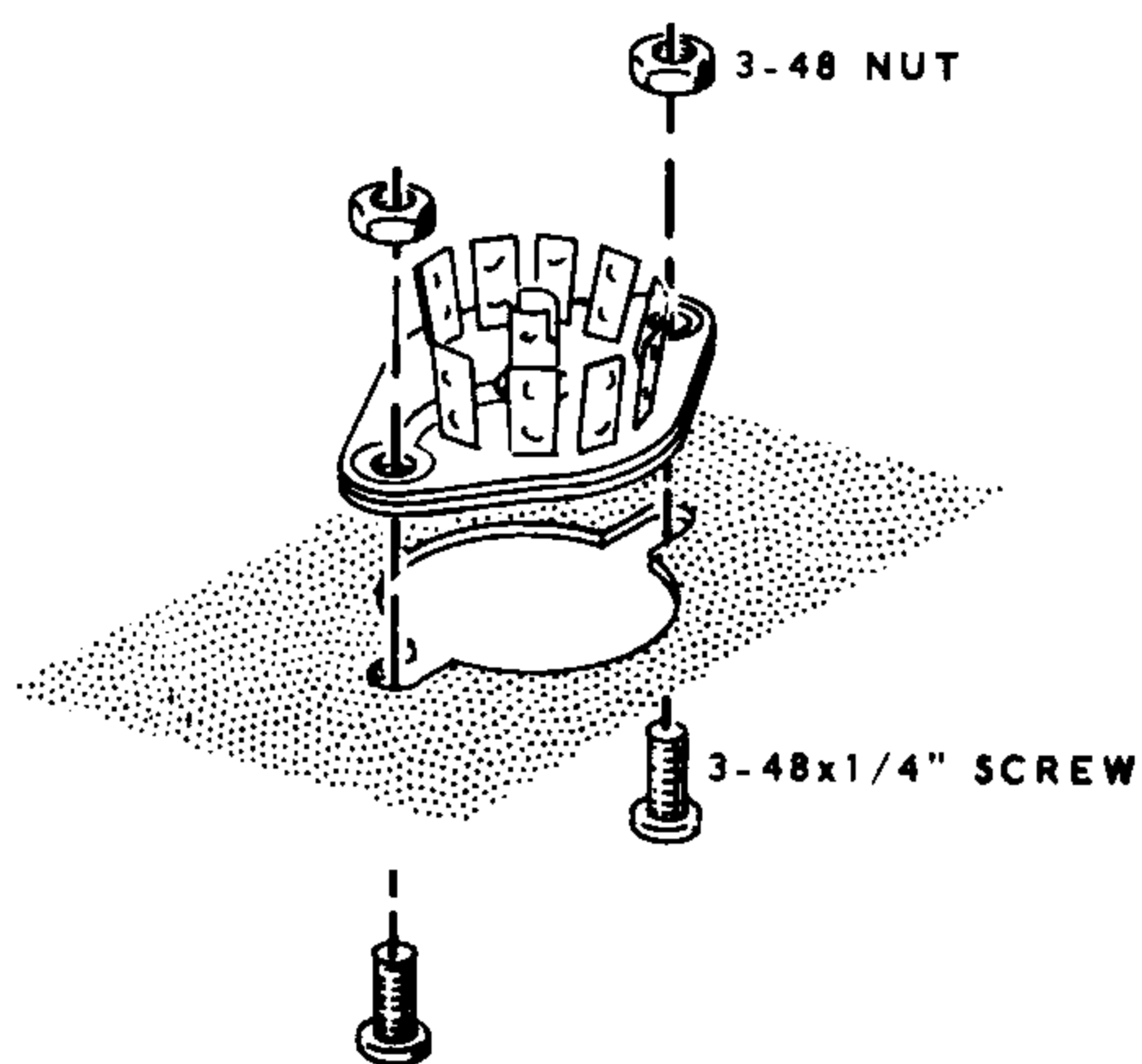

Detail 1A

Terminal strips will be mounted in the next five steps. Refer to Detail 1B and use a 6-32 x 1/4" screw, two #6 lockwashers, and a 6-32 nut to mount each terminal strip. Also, position the terminal strips as shown in the Pictorial.

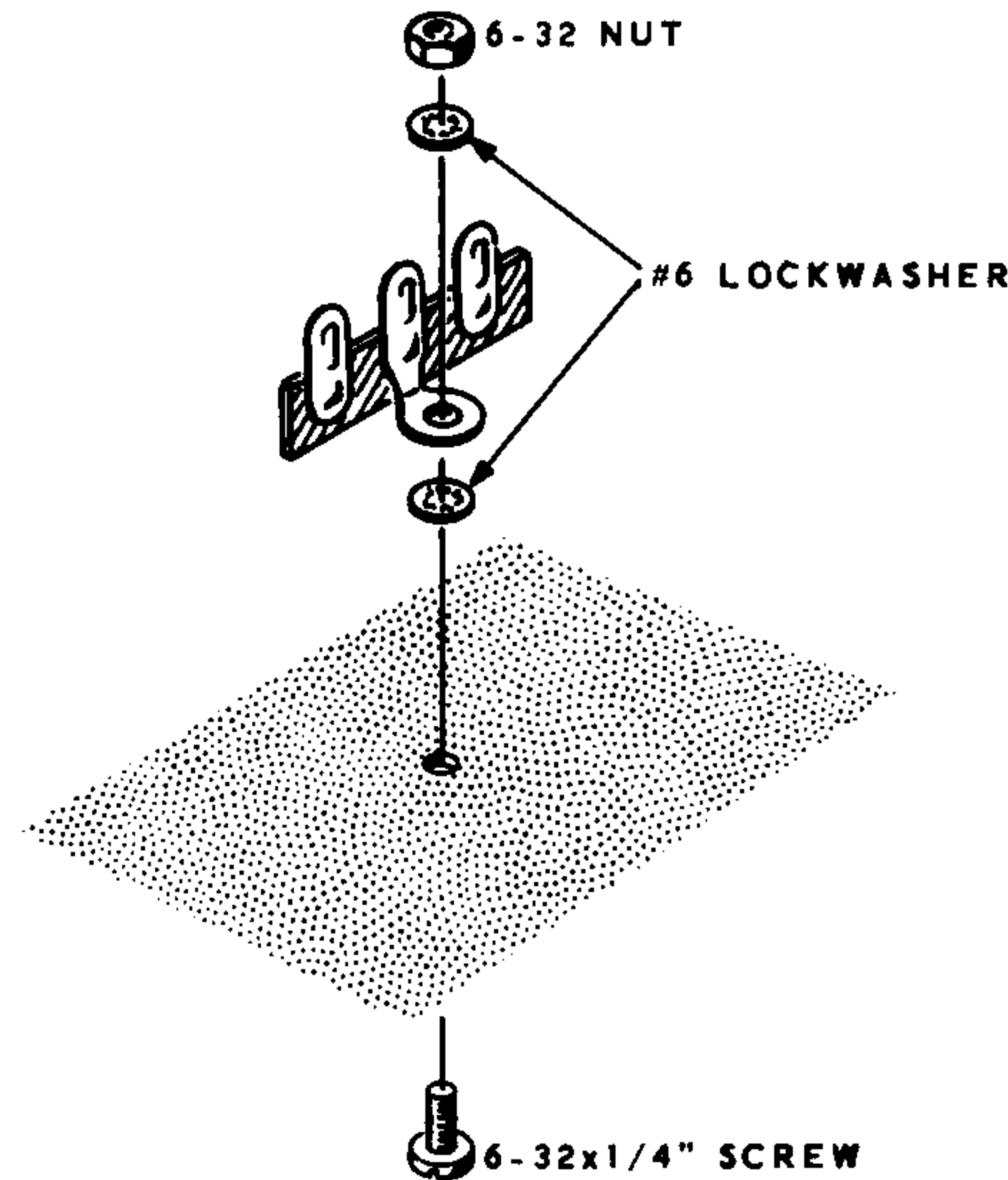

Detail 1B

- ( ) 3-lug terminal strip at C.
- ( ) 3-lug terminal strip at D.
- ( ) 4-lug terminal strip at B.
- ( ) 4-lug terminal strip at L.
- ( ) 5-lug terminal strip at S.

In the following steps, when the instructions call for using 6-32 hardware, use a 6-32 x 1/4" screw, #6 lockwasher, and 6-32 nut. When a #6 solder lug is used, the #6 lockwasher will not be used.

- ( ) Install a #6 solder lug on the bottom side of the chassis at A. Use 6-32 hardware.
- ( ) Similarly, install #6 solder lugs at J and P using 6-32 hardware.
- ( ) Install a #6 solder lug on the top side of the chassis at T. Use 6-32 hardware and position it as shown in Pictorial 1.

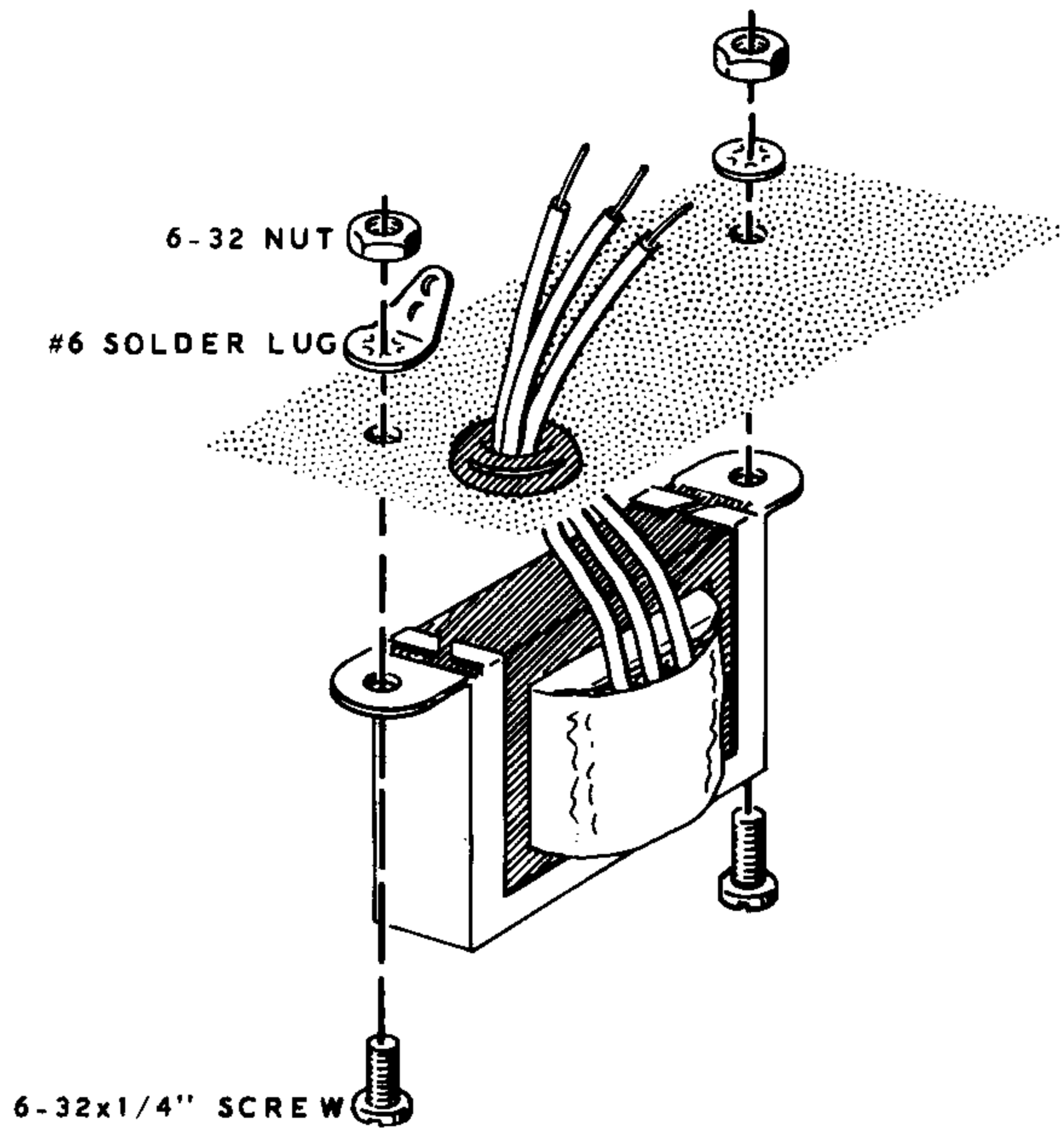

Detail 1C

( ) Refer to Detail 1C and mount the oscillator transformer (#51-44) on the top side of the chassis at F. Use 6-32 hardware and install a #6 solder lug at E on the bottom side of the chassis. Position the transformer as shown and insert the three leads through grommet HB.

( ) Refer to Detail 1D and mount the 1-10  $\mu$ f trimmer capacitor at K. Place the locating tab in the slot, as shown, and press down until both retaining tabs snap into place.

**FRONT PANEL MOUNTING**

( ) Locate the front panel. Position the panel so that the largest hole in the panel is in line with the hole at FB on the front flange of the chassis.

( ) Mount the front panel on the chassis by mounting the 100 K $\Omega$  control with SPST switch (#19-11) at FC. Refer to Detail 1E and use a control lockwasher, control flat washer, and control nut. Position the control as shown and do not tighten the control nut.

( ) Refer to Detail 1F and mount the 2-position rotary switch (#63-211) at FE. Use a control solder lug, control flat washer, and control nut. Position the control solder lug and the switch as shown. Do not tighten the control nut.

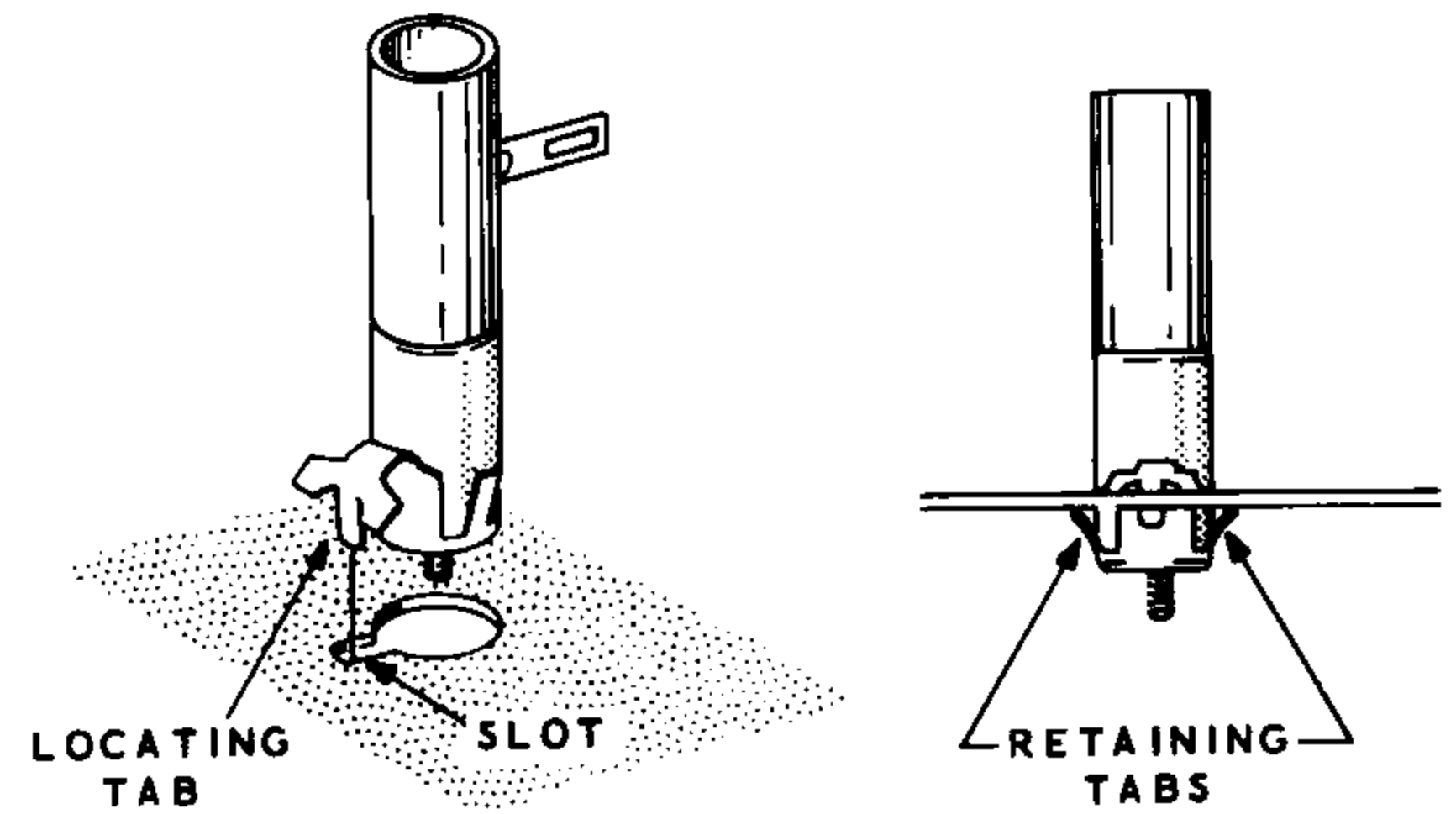

Detail 1D

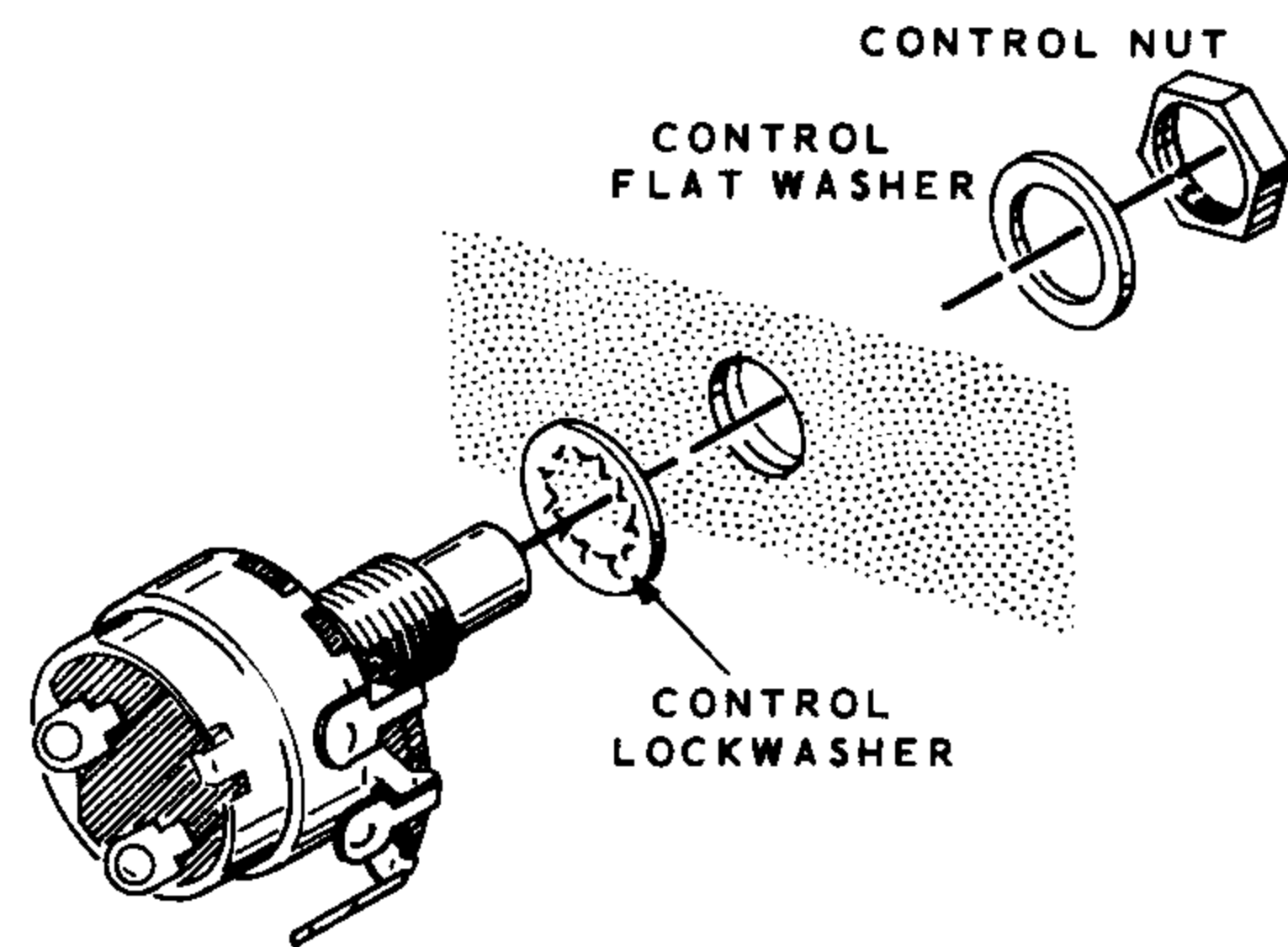

Detail 1E

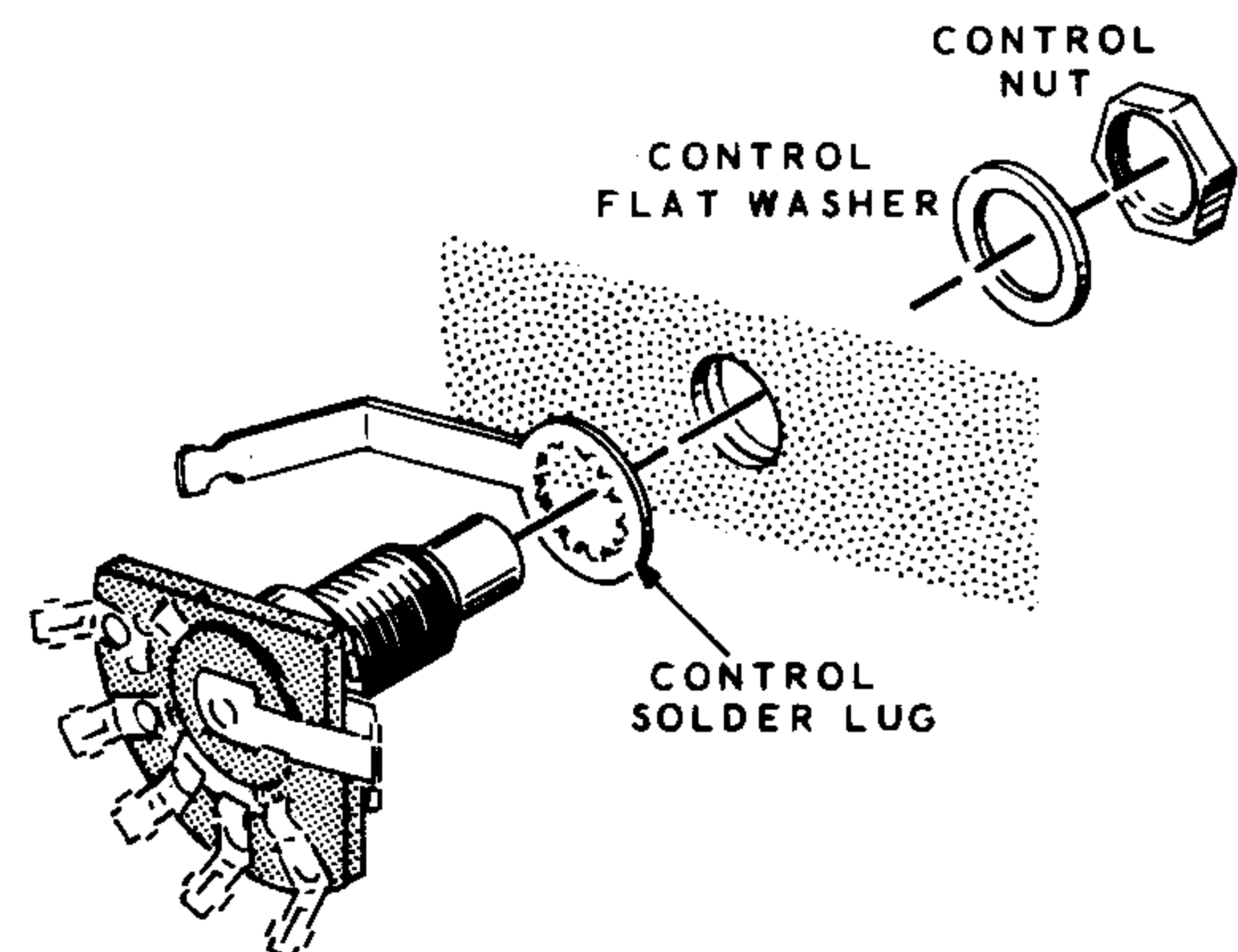

Detail 1F

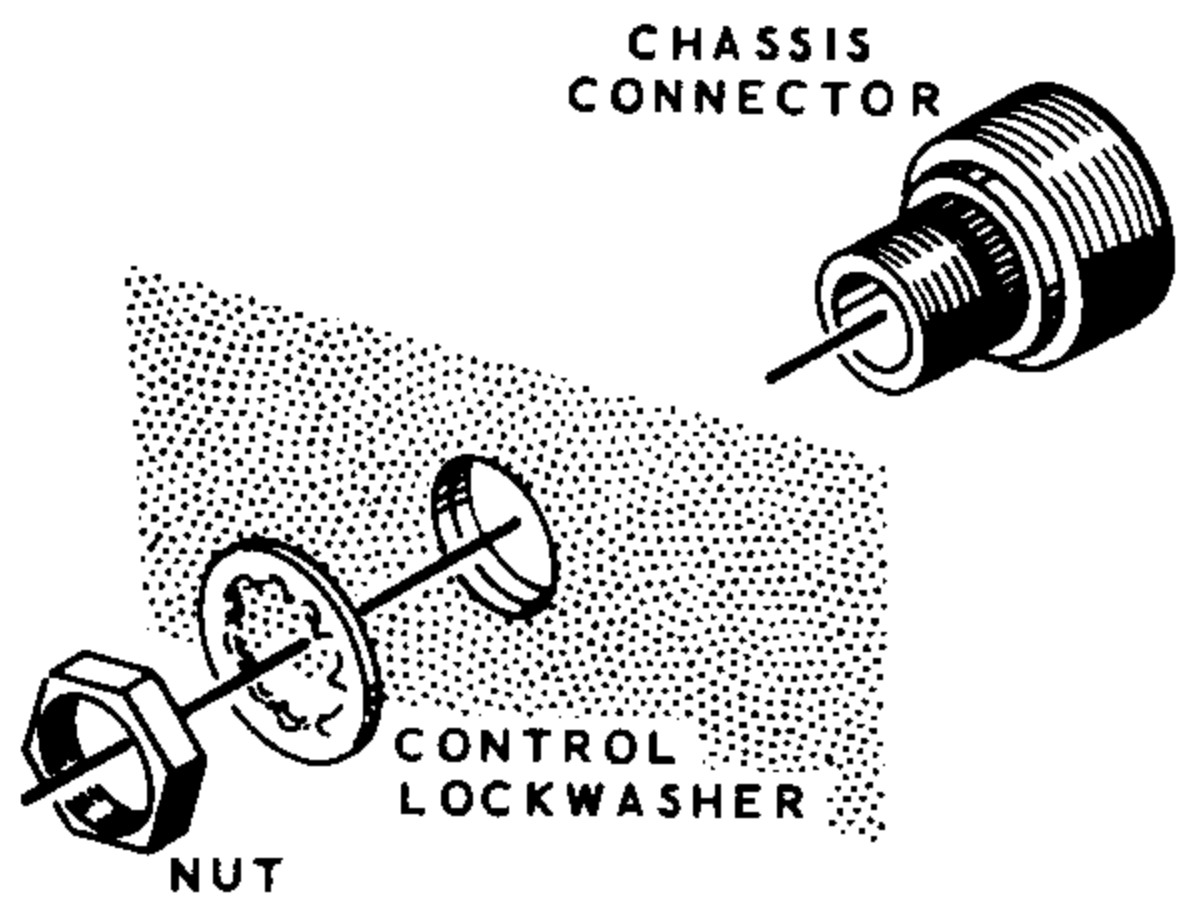

Detail 1G

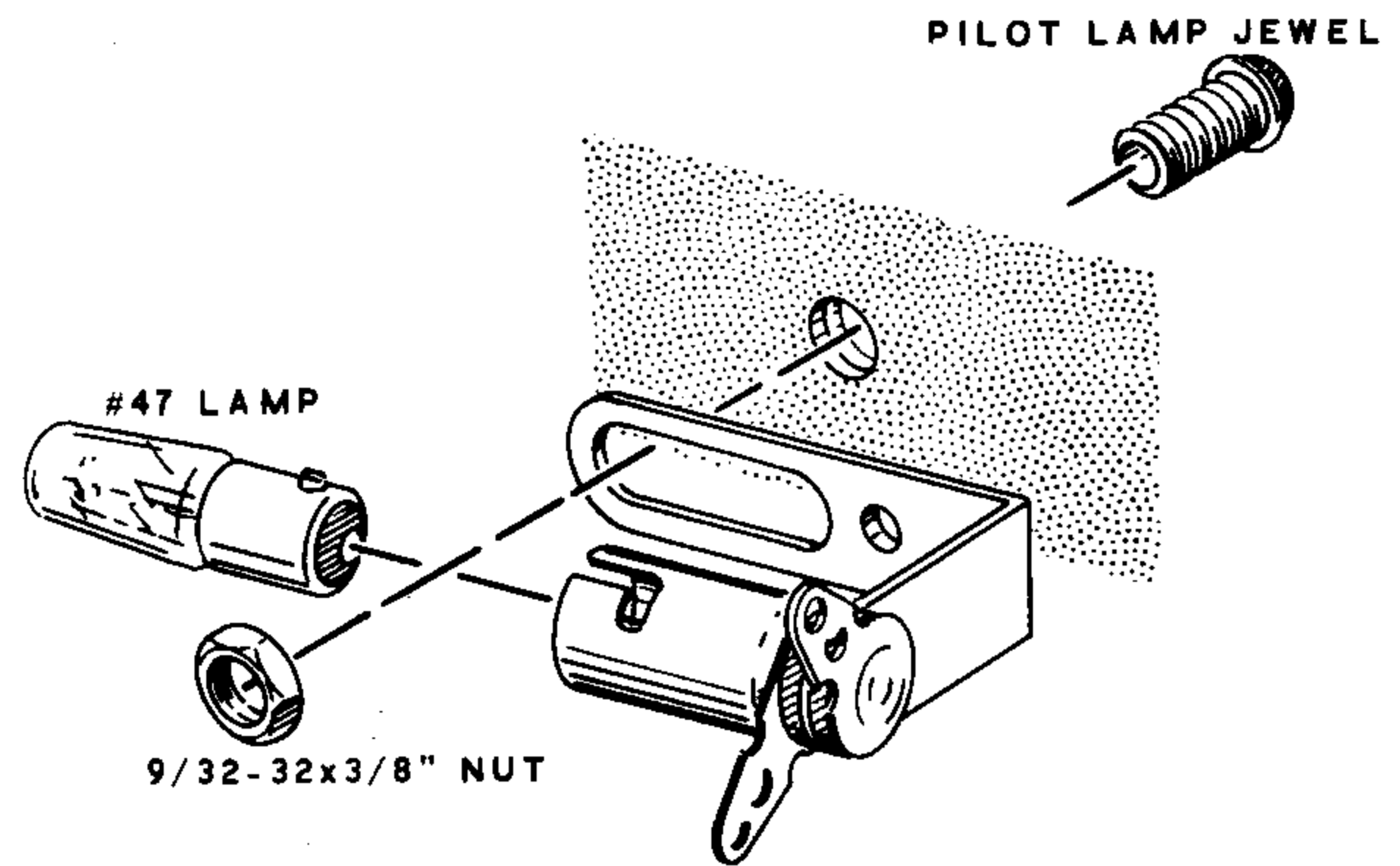

Detail 1H

- ( ) Refer to Detail 1G and mount a chassis connector at FF. Use a control lockwasher and the nut supplied with the connector. Discard the solder lug supplied with the connector.
- ( ) Similarly, mount the remaining chassis connector at FG.
- ( ) Now tighten the control nuts on the control at FC and the switch at FE.
- ( ) Refer to Detail 1H and mount the pilot lamp socket at FA. Position the socket as shown and use the pilot lamp jewel and a 9/32-32 x 3/8" nut.
- ( ) Install the #47 lamp in the pilot lamp socket.
- ( ) Refer to Detail 1J and cut the power transformer (#54-92) leads to the lengths as shown. Do not shorten one of the yellow leads. Measure the leads from the bottom edge of the transformer as shown.
- ( ) Remove 1/4" of insulation from the end of each transformer lead. Then melt a small amount of solder on the end of each exposed lead to hold the wire strands together.

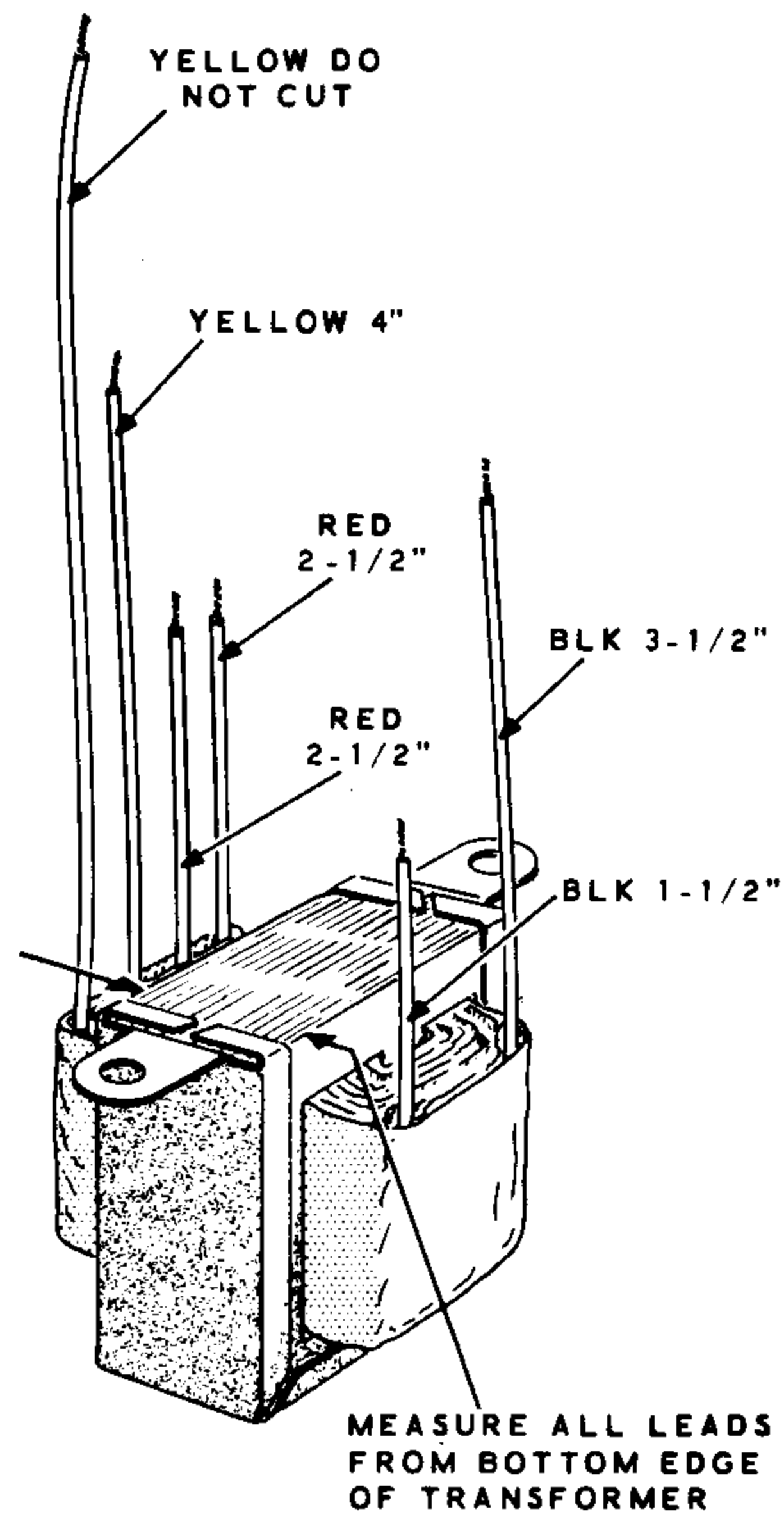

Detail 1J

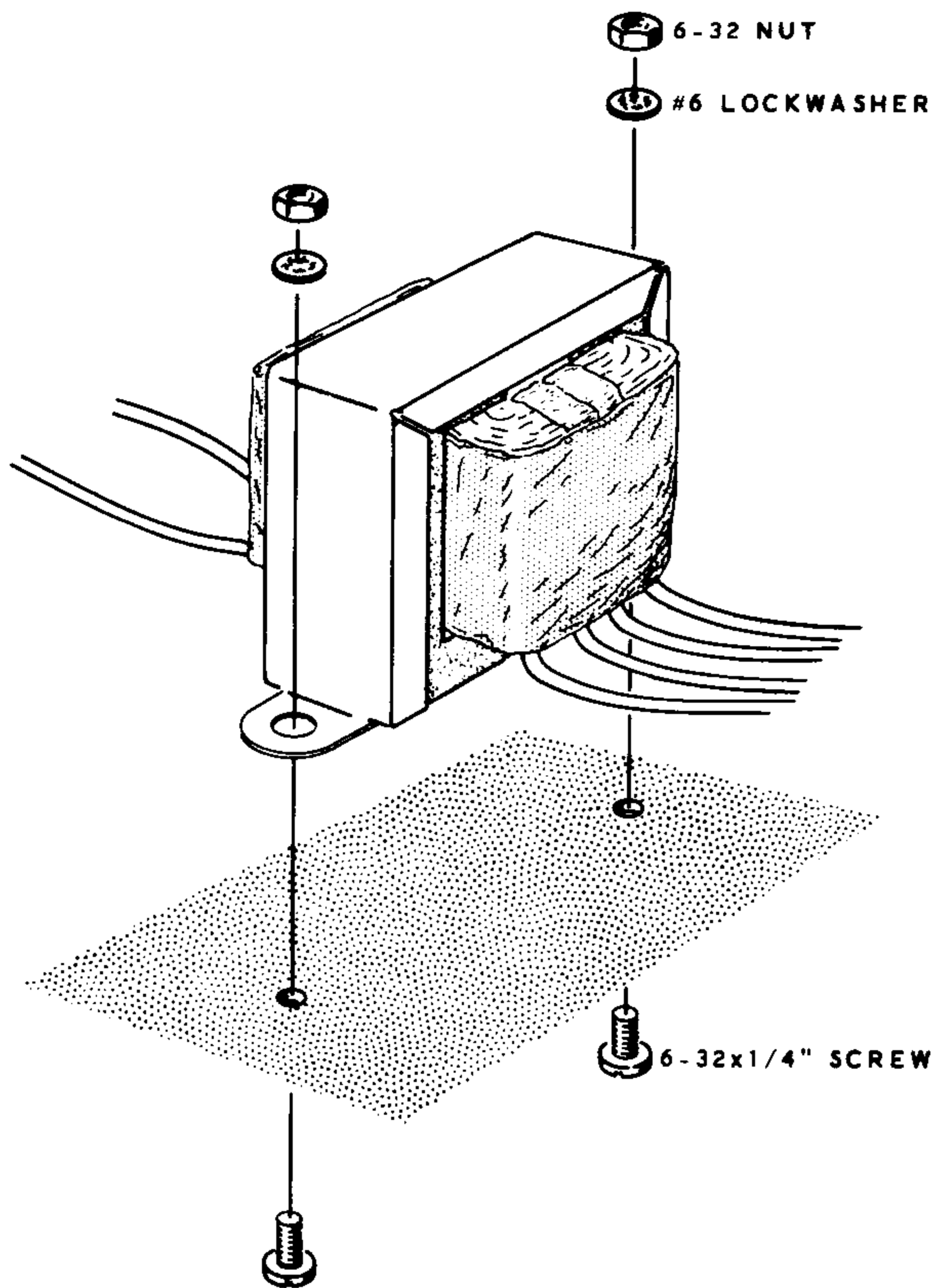

Detail 1K

- ( ) Refer to Detail 1K and mount the power transformer at N. Position the transformer with the two black leads toward terminal strip S. Use 6-32 hardware.

### FRONT PANEL PARTS MOUNTING AND WIRING

Refer to Pictorial 2 for the following steps.

- ( ) Turn the chassis and front panel assembly over and position it as shown in the Pictorial.
- ( ) Refer to Detail 2A and mount the 3-position rotary switch (#63-70) at FH. Use a control lockwasher, control solder lug, control flat washer, and a control nut. Position the switch and control solder lug as shown in the Pictorial.

- ( ) Mount the 3000  $\Omega$  control (#10-27) at FJ using two control lockwashers, a control flat washer, and a control nut. Position the control as shown.

Precut the following lengths of hookup and bare wire. Remove 1/4" of insulation from the ends of each length of hookup wire. Do not use the shielded or coaxial cable unless it is specifically called for. The wires are listed in the sequence that they will be used.

- ( ) Prepare the following lengths of wire.

2-1/2" hookup wire  
5-1/2" hookup wire  
2-3/4" bare wire

- ( ) Connect a 2-1/2" wire from lug 8 of switch FH (S-1) to lug 2 of control FJ (S-1).
- ( ) Connect one end of a 5-1/2" wire to lug 1 of control FJ (S-1). Insert the other end of the wire through grommet HC to be connected later.
- ( ) Connect a 2-3/4" bare wire from lug 3 of control FJ (S-1), around the control solder lug at switch FH (S-2), to lug 5 of switch FH (NS).

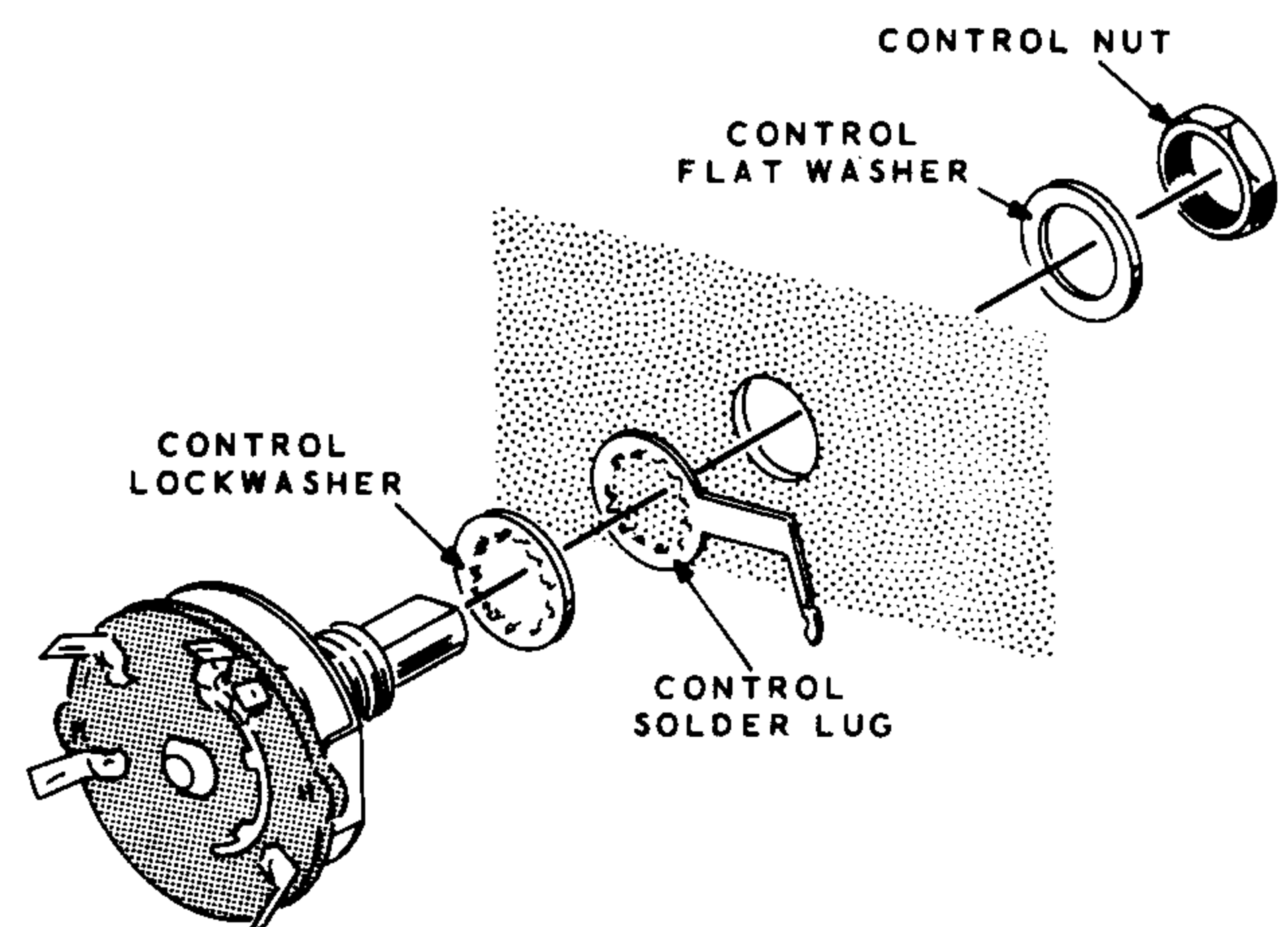

Detail 2A



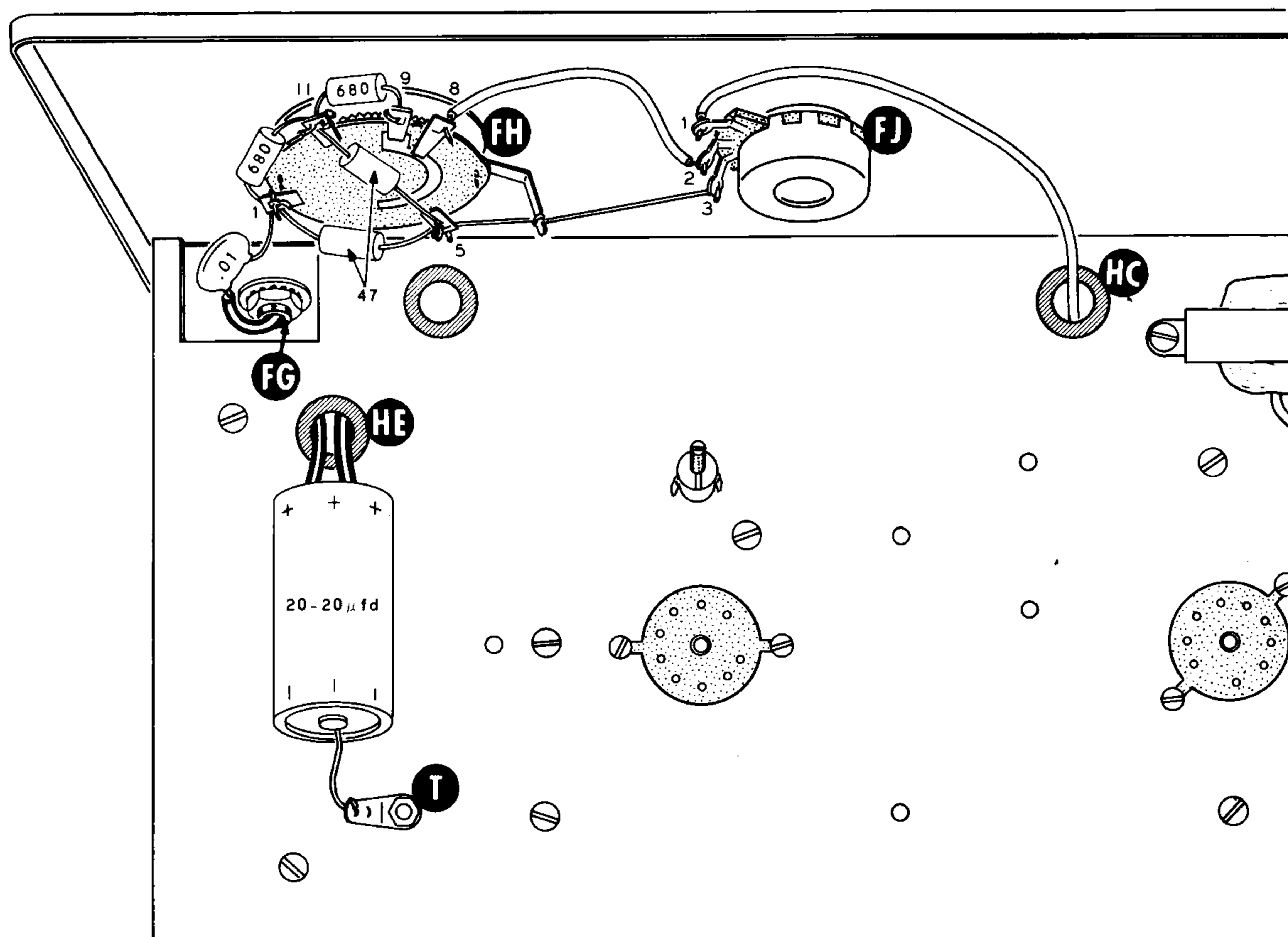

PICTORIAL 2

- ( ) Place a 3/4" length of sleeving on one lead of a .01  $\mu$ fd disc ceramic capacitor, and connect this lead to the eyelet in chassis connector FG (S-1). After soldering, cut off any excess lead at the eyelet and position the capacitor in the chassis cutout as shown.
  - ( ) Connect the other lead of this capacitor to lug 1 of switch FH (NS). This lead should be as short and direct as possible.
- NOTE: All resistors used in the following steps are 1/2 watt unless specified otherwise in the step.
- ( ) Connect a 47  $\Omega$  (yellow-violet-black) resistor between lugs 1 (NS) and 5 (NS) of switch FH.
  - ( ) Connect a 47  $\Omega$  (yellow-violet-black) resistor between lugs 11 (NS) and 5 (S-3) of switch FH.
  - ( ) Connect a 680  $\Omega$  (blue-gray-brown) resistor between lugs 1 (S-3) and 11 (NS) of switch FH.
  - ( ) Connect a 680  $\Omega$  (blue-gray-brown) resistor between lugs 11 (S-3) and 9 (S-1) of switch FH.
  - ( ) Place a 1" length of sleeving on one positive (+) lead of the 20-20  $\mu$ fd electrolytic capacitor.
  - ( ) Place a 2" length of sleeving on the other positive (+) lead of this capacitor.
  - ( ) Insert both positive leads of the 20-20  $\mu$ fd electrolytic capacitor through grommet HE to be connected later. Connect the negative (-) lead of the capacitor to solder lug T (S-1).

### CHASSIS WIRING

Refer to Pictorial 3 (fold-out from Page 13) for the following steps.

- ( ) Position the chassis as shown in the Pictorial.

The oscillator transformer leads coming through grommet HB will be connected in the next three steps.

- ( ) Yellow to lug 3 of tube socket V2 (NS).
- ( ) Black to lug 2 of terminal strip C (NS).
- ( ) Red to lug 1 of terminal strip C (NS).

The leads coming from power transformer N will be connected in the next six steps.

- ( ) Short black to lug 5 of terminal strip S (NS).
- ( ) Other black to lug 2 of terminal strip S (NS).
- ( ) Longer yellow to lug 5 of tube socket V1 (NS).
- ( ) Other yellow to lug 3 of terminal strip S (NS).
- ( ) Either red to lug 2 of terminal strip L (NS).
- ( ) Other red to lug 3 of terminal strip L (S-1).

The free leads of the 20-20  $\mu$ fd electrolytic capacitor coming through grommet HE, will be connected in the next two steps.

- ( ) Lead with the longer length of sleeving to lug 4 of terminal strip L (NS).
- ( ) The other lead to lug 1 of terminal strip L (NS).
- ( ) Prepare the following lengths of hookup wire:

|        |  |        |
|--------|--|--------|
| 3-1/2" |  | 9-1/2" |
| 13"    |  | 2-3/4" |
| 9"     |  | 2-1/2" |
| 2"     |  |        |

- ( ) Connect a 3-1/2" wire from lug 1 of terminal strip B (NS) to lug 1 of terminal strip D (NS).
- ( ) Connect a 13" wire from lug 1 of tube socket V2 (NS) to lug 2 of switch FE (S-1).
- ( ) Connect a 9" wire from lug 4 of tube socket V2 (NS) to lug 5 of tube socket V1 (NS). Position the wire as shown.
- ( ) Connect a 2" wire from lug 7 of tube socket V2 (S-1) to lug 1 of terminal strip D (NS).
- ( ) Connect a 9-1/2" wire from lug 1 of terminal strip D (NS) to lug 1 of terminal strip L (NS).
- ( ) Connect a 2-3/4" wire from lug 1 of pilot lamp socket FA (S-1) to lug 4 of the tube socket V2 (S-2).
- ( ) Connect a 2-1/2" wire from lug 3 of control FC (S-1) to lug 3 of switch FE (S-1).
- ( ) Connect the free end of the wire coming through grommet HC to lug 3 of terminal strip D (NS).
- ( ) Precut the following lengths of bare wire:
 

|        |  |        |
|--------|--|--------|
| 1-1/2" |  | 2-1/2" |
| 2"     |  | 3"     |
| 1"     |  |        |
- ( ) Connect a 1-1/2" bare wire from solder lug E (NS) to lug 2 of pilot lamp socket FA (S-1).
- ( ) Place one end of a 2" bare wire through the center post (NS) to lug 5 (S-1) of tube socket V2. Place a 3/4" length of sleeving on the other end of this wire and connect it to lug 3 of terminal strip B (NS).
- ( ) Connect a 1" bare wire from trimmer capacitor K (S-1) to lug 2 of tube socket V1 (NS).
- ( ) Place one end of a 2-1/2" bare wire through lug 9 (S-2) to the center post (NS) of tube socket V1. Connect the other end of this bare wire to solder lug J (NS).

- ( ) Connect a 3" bare wire from lug 1 of control FC (NS) to the control solder lug at switch FE (NS).
- ( ) Refer to Detail 3A and twist two 12" wires together to form a twisted pair. Remove 1/4" of insulation from each end of both wires.

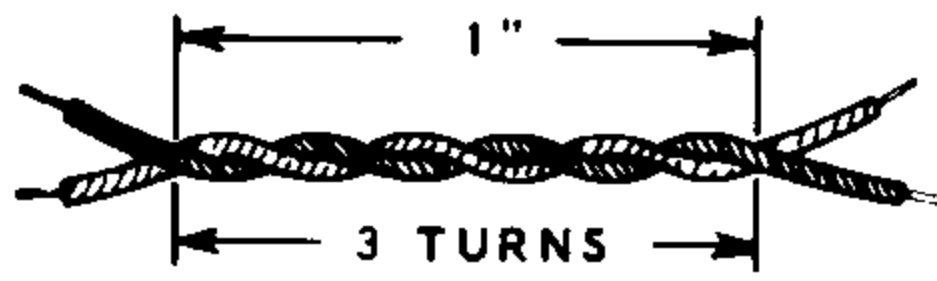

Detail 3A

- ( ) At one end of this twisted pair, connect either wire to lug 4 (S-1) and the other wire to lug 5 (S-1) of control FC.
- ( ) At the other end of the twisted pair, connect either wire to lug 4 (NS) and the other wire to lug 5 (S-2) of terminal strip S. Route the twisted pair as shown in Pictorial 3 and position it down against the chassis.
- ( ) Refer to Detail 3B and prepare a 16" length of 2-lead shielded cable.

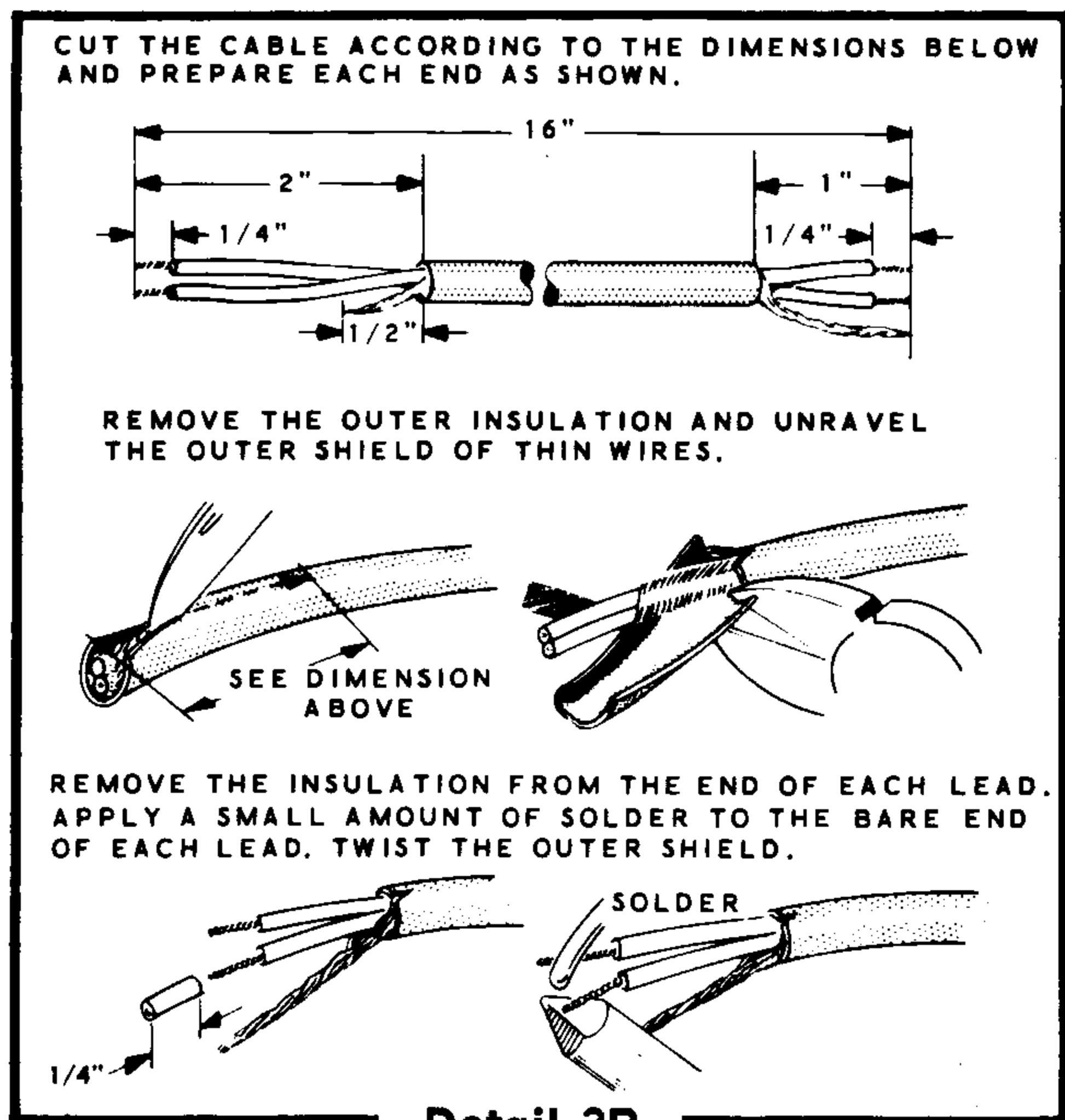

- ( ) Insert the end of the cable with the longest inner leads through grommet HA from the top side of the chassis.

Connect the leads at this end of the 2-lead shielded cable as follows.

- ( ) Shield to solder lug A (S-1).
- ( ) Yellow to lug 2 of tube socket V2 (NS).
- ( ) Green to lug 3 of terminal strip C (NS).
- ( ) Insert the other end of the 2-lead shielded cable through grommet HD from the top side of the chassis.

Connect the leads at this end of the 2-lead shielded cable as follows.

- ( ) Shield to the control solder lug at switch FE (S-2).
- ( ) Yellow to lug 4 of switch FE (S-1).
- ( ) Green to lug 5 of switch FE (S-1).
- ( ) Place two cable clamps over the 2-lead shielded cable and secure them at X and Y on the top of the chassis. Refer to Detail 3C and use 6-32 x 3/8" screws, #6 lockwashers, and 6-32 nuts.

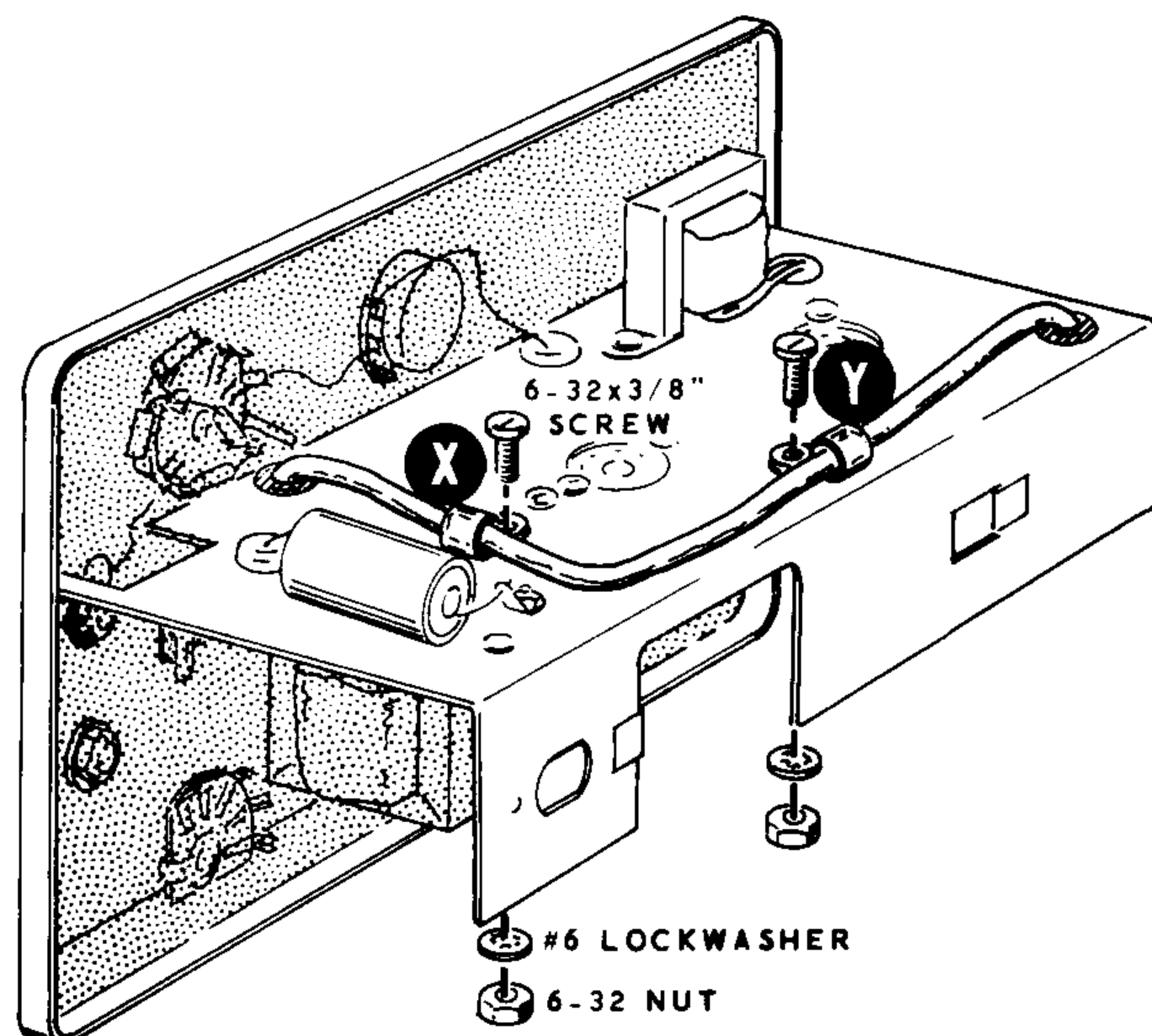

Detail 3C

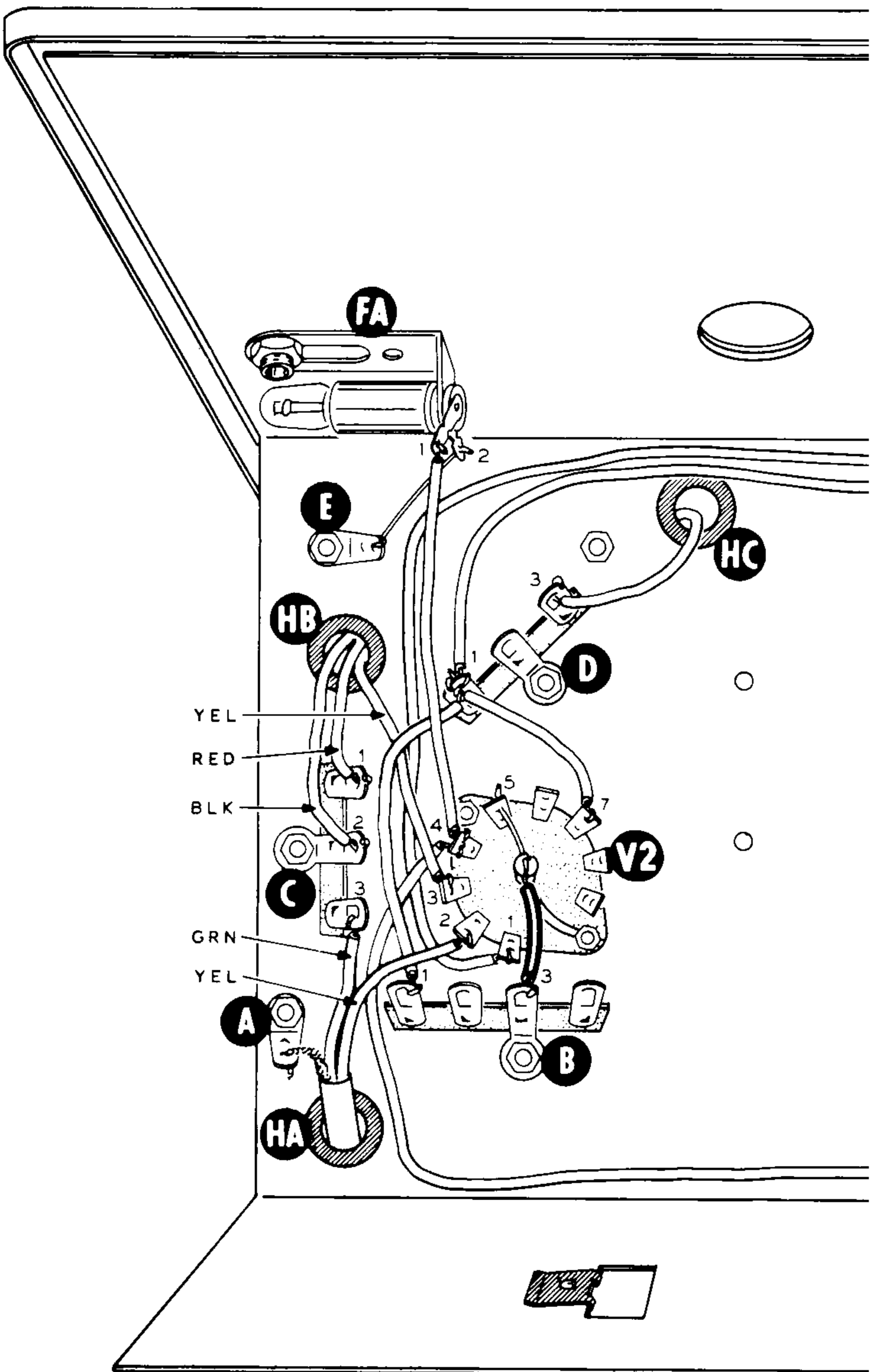

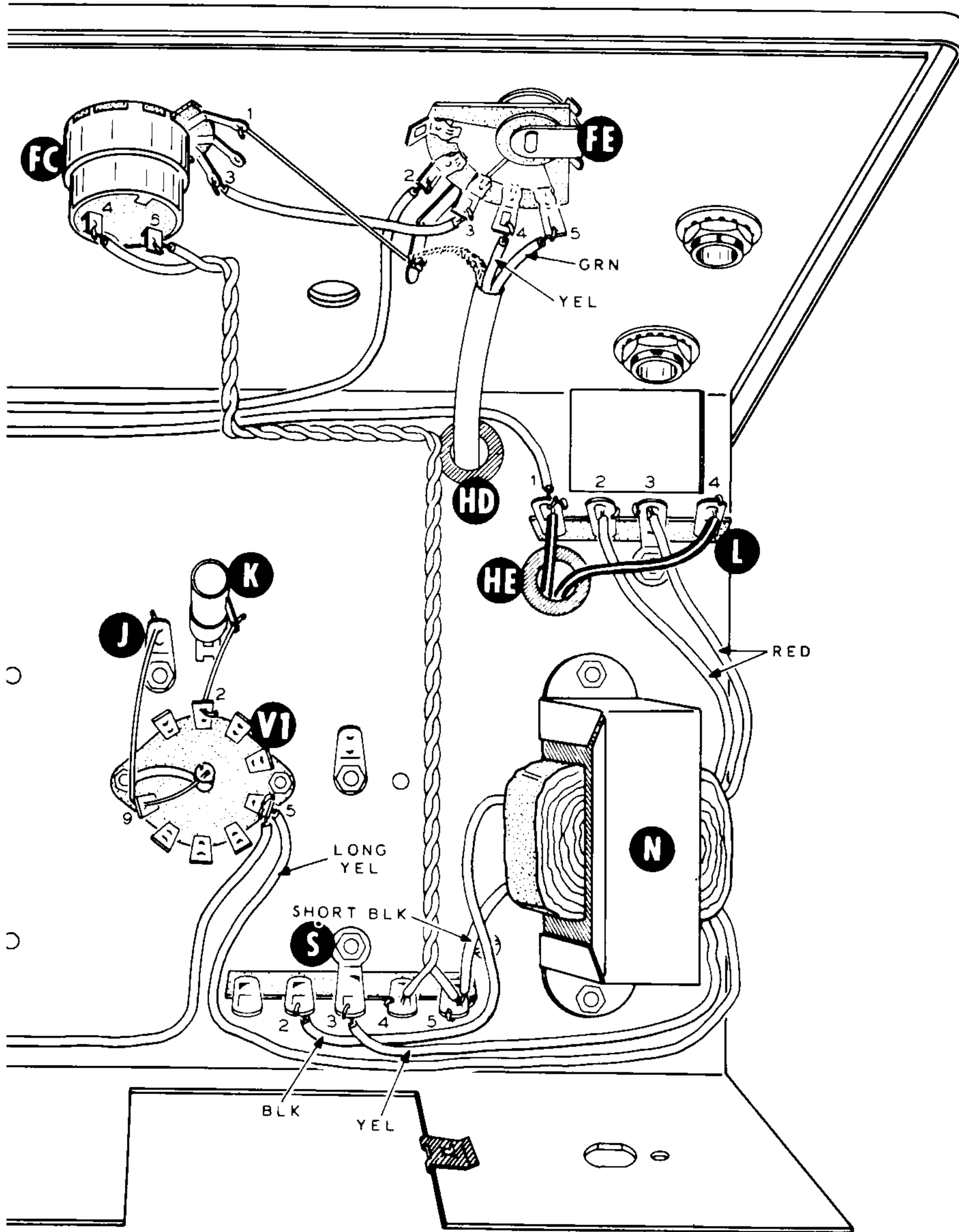

**ICTORIAL 3**



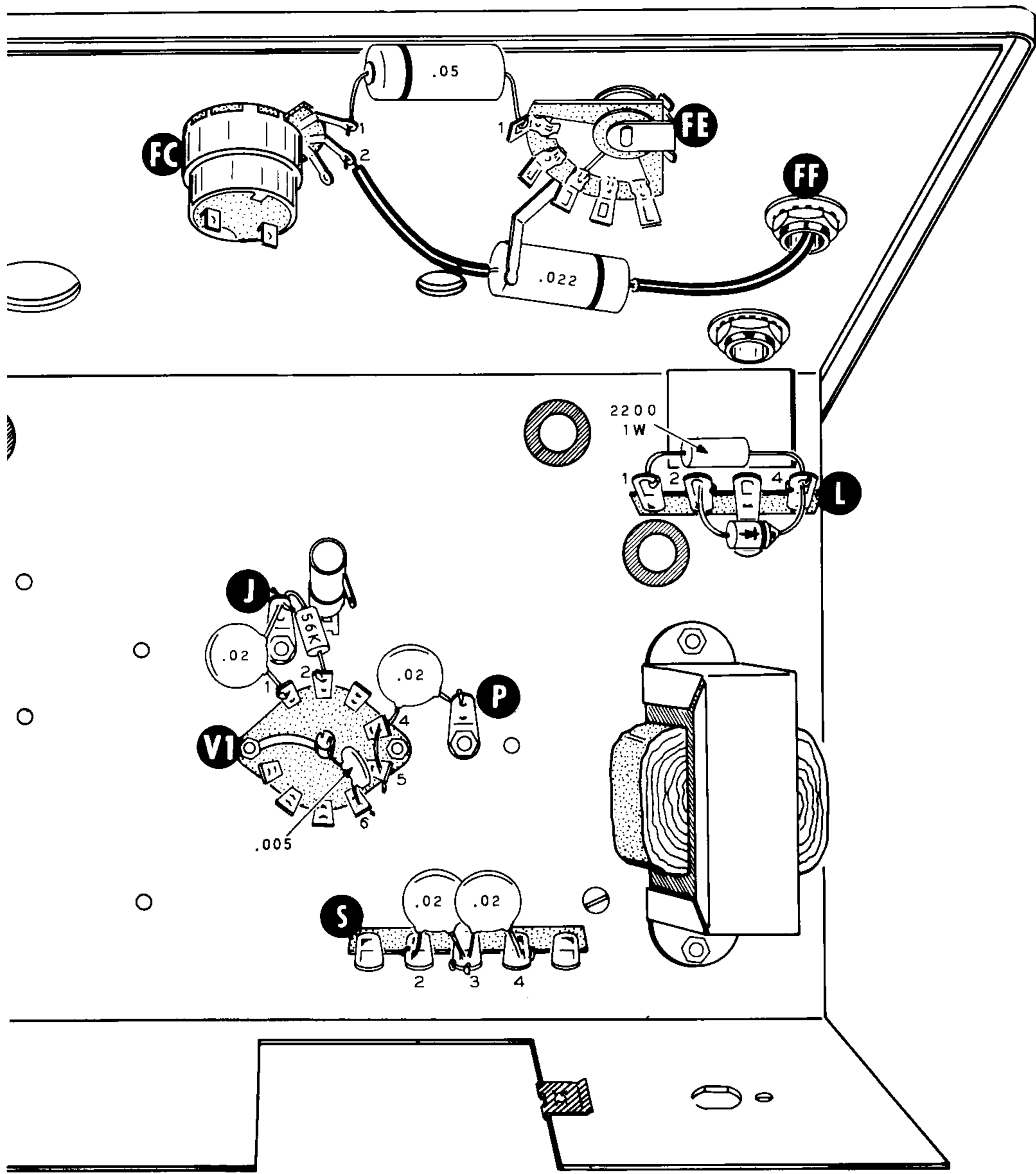

**PICTORIAL 4**

## COMPONENT INSTALLATION

Refer to Pictorial 4 for the following steps.

NOTE: Before installing the tubular capacitors, identify the marked end of each one. Refer to Detail 4A. Each capacitor should be connected with the marked end as shown in the Pictorial.

NOTE MARKING ON TUBULAR CAPACITOR  
EITHER SHOULDER OR BAND

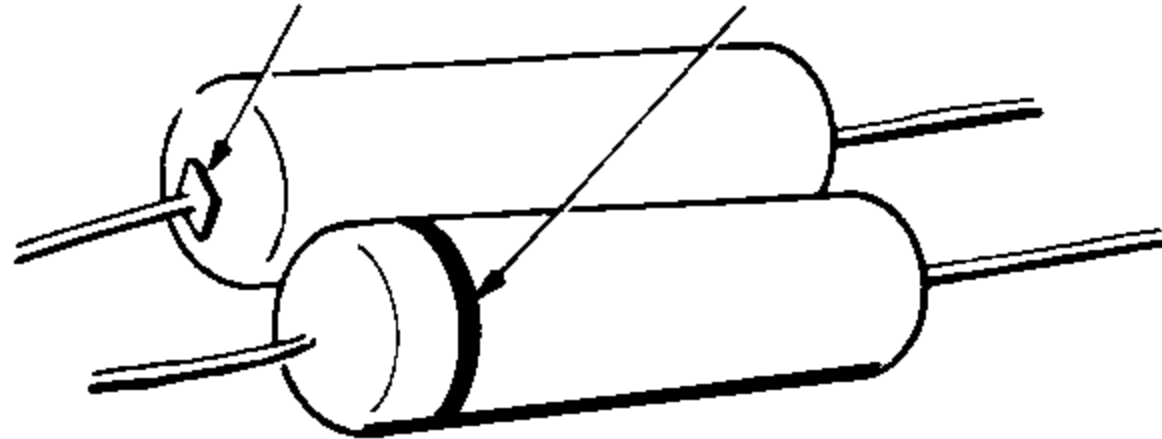

MARKED END MUST BE PLACED  
AS SHOWN IN THE PICTORIAL

Detail 4A

- ( ) Connect a .1  $\mu\text{fd}$  tubular capacitor from solder lug E (S-2) to lug 1 of terminal strip C (NS).
  - ( ) Connect a .0047  $\mu\text{fd}$  tubular capacitor between lugs 1 (S-3) and 3 (S-2) of terminal strip C.
- NOTE: All resistors used in the following steps are 1/2 watt unless specified otherwise in the step.
- ( ) Connect a 33 K $\Omega$  (orange-orange-orange) resistor between lugs 3 (NS) and 4 (NS) of terminal strip B.
  - ( ) Connect a .001  $\mu\text{fd}$  disc ceramic capacitor between lugs 3 (NS) and 4 (NS) of terminal strip B.
  - ( ) Connect a 100 K $\Omega$  (brown-black-yellow) resistor between lugs 2 (NS) and 4 (NS) of terminal strip B.
  - ( ) Connect a 390  $\Omega$  (orange-white-brown) resistor from lug 9 of tube socket V2 (NS) to lug 3 of terminal strip B (S-4).
  - ( ) Connect a 47  $\mu\text{fd}$  disc ceramic capacitor between the center post (NS) and lug 9 (S-2) of tube socket V2.
  - ( ) Connect a 100 K $\Omega$  (brown-black-yellow) resistor from lug 8 of tube socket V2 (NS) to lug 4 of terminal strip B (S-4).
  - ( ) Connect a 4700  $\Omega$  (yellow-violet-red) resistor from lug 1 of tube socket V2 (NS) to lug 1 of terminal strip B (S-2).
  - ( ) Connect a .01  $\mu\text{fd}$  disc ceramic capacitor from lug 1 of tube socket V2 (NS) to lug 2 of terminal strip B (S-2).
  - ( ) Connect a .001  $\mu\text{fd}$  disc ceramic capacitor between the center post (S-4) and lug 1 (S-4) of tube socket V2.
  - ( ) Connect a 100 K $\Omega$  (brown-black-yellow) resistor from lug 2 of tube socket V2 (S-2) to lug 2 of terminal strip C (NS).
  - ( ) Connect a .01  $\mu\text{fd}$  disc ceramic capacitor from lug 3 of tube socket V2 (S-2) to lug 2 of terminal strip C (S-3).
  - ( ) Connect a 680  $\Omega$  (blue-gray-brown) resistor from lug 6 of tube socket V2 (NS) to lug 1 of terminal strip D (NS).
  - ( ) Connect a .01  $\mu\text{fd}$  disc ceramic capacitor from lug 6 of tube socket V2 (S-2) to lug 3 of terminal strip D (S-2).
  - ( ) Connect a .02  $\mu\text{fd}$  disc ceramic capacitor between lugs 1 (S-5) and 2 (S-1) of terminal strip D.
  - ( ) Connect a .02  $\mu\text{fd}$  disc ceramic capacitor between lugs 2 (NS) and 3 (NS) of terminal strip S.
  - ( ) Connect a .02  $\mu\text{fd}$  disc ceramic capacitor between lugs 3 (S-3) and 4 (NS) of terminal strip S.
  - ( ) Connect a 56 K $\Omega$  (green-blue-orange) resistor from lug 2 of tube socket V1 (NS) to solder lug J (NS).
  - ( ) Connect a .02  $\mu\text{fd}$  disc ceramic capacitor from lug 1 of tube socket V1 (NS) to solder lug J (S-3).
  - ( ) Insert one lead of a .02  $\mu\text{fd}$  disc ceramic capacitor through lug 4 (S-2) to lug 5 (S-3) of tube socket V1. Position the capacitor against the chassis as shown, and connect the other lead of this capacitor to solder lug P (S-1).
  - ( ) Connect a .005  $\mu\text{fd}$  disc ceramic capacitor between lug 6 (NS) and the center post (S-2) of tube socket V1.
  - ( ) Connect a 2200  $\Omega$  (red-red-red) 1 watt resistor between lugs 1 (NS) and 4 (NS) of terminal strip L.



NOTE: WHEN INSTALLING DIODES THE CATHODE END MUST BE PLACED AS DIRECTED. THE CATHODE END IS MARKED WITH EITHER A COLOR END, COLOR DOT, OR COLOR BAND.

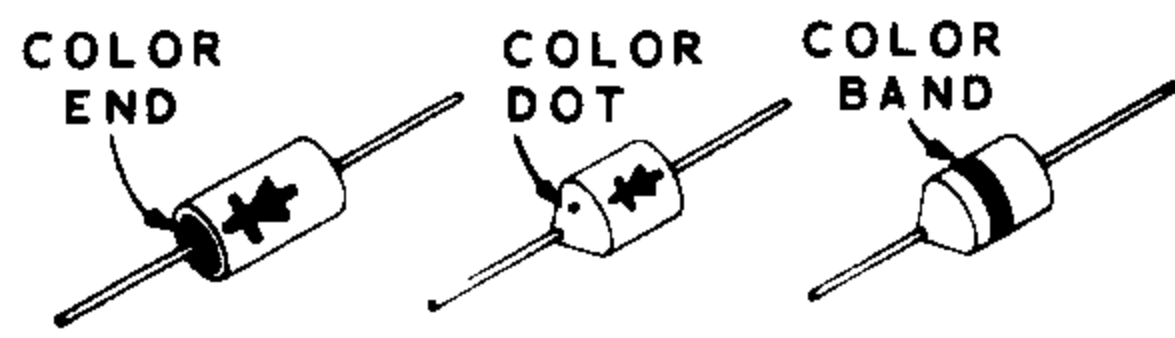

Detail 4B

- ( ) Refer to Detail 4B and identify the cathode lead of a silicon diode.
- ( ) Connect the cathode lead of a silicon diode to lug 4 of terminal strip L (S-3). Connect the other lead of this diode to lug 2 of terminal strip L (S-2).
- ( ) Connect a .05  $\mu$ fd tubular capacitor from lug 1 of control FC (S-2) to lug 1 of switch FE (S-1).
- ( ) Place a 1-1/2" length of sleeving on each lead of a .022  $\mu$ fd tubular capacitor. Connect this capacitor from lug 2 of control FC (S-1) to chassis connector FF (S-1).

Refer to Pictorial 5 (fold-out from Page 21) for the following steps.

NOTE: Keep the plates of the dual tuning capacitor fully meshed during the remaining assembly of the kit except when instructed otherwise.

- ( ) Locate the dual tuning capacitor (#26-57). Refer to Detail 5A and install a 6-32 x 3/16" screw and a #6 solder lug on each end of the capacitor.

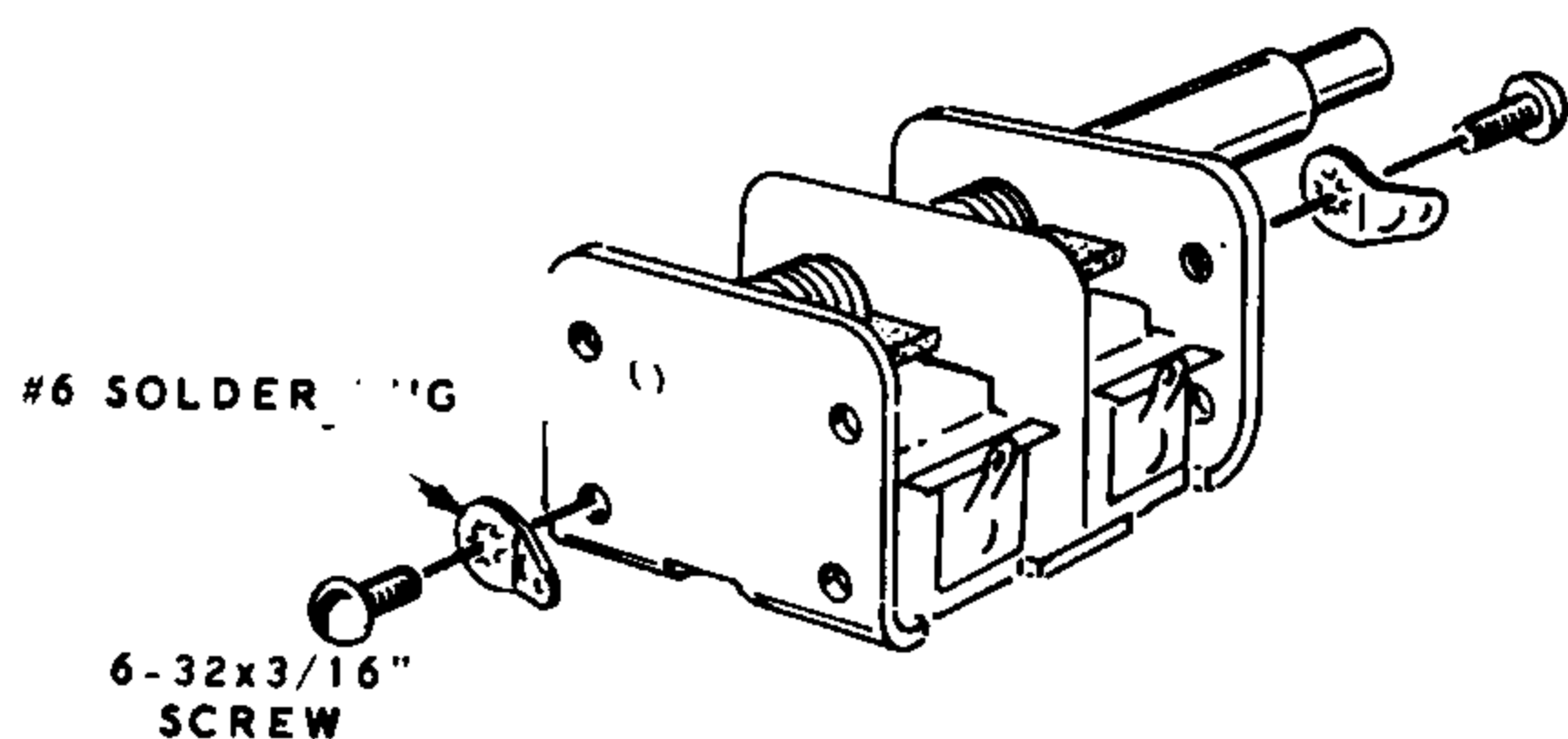

Detail 5A

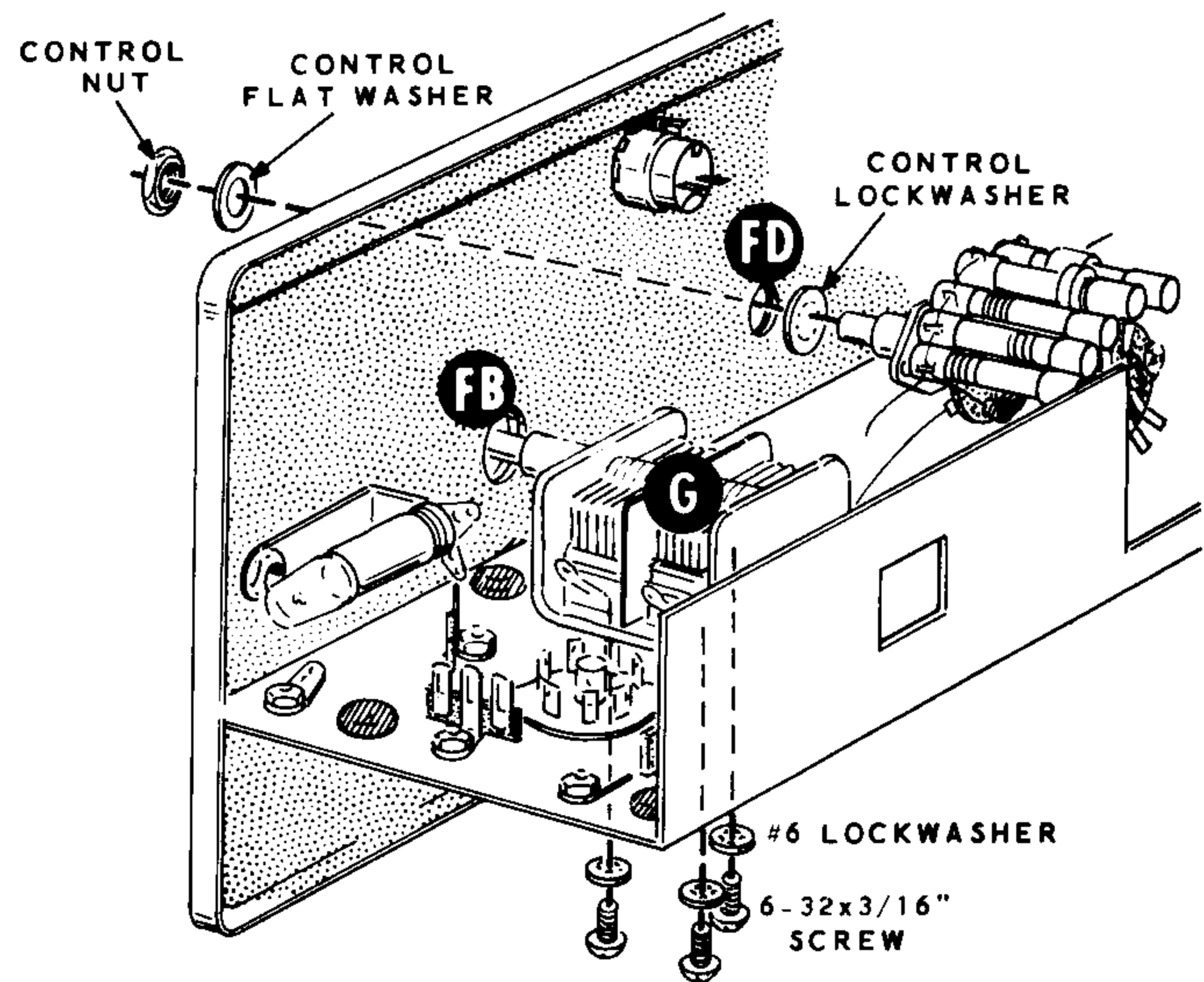

Detail 5B

- ( ) Refer to Detail 5B and mount the tuning capacitor at G. Use 6-32 x 3/16" screws and #6 lockwashers. Center the capacitor shaft in hole FB before tightening the screws.
- ( ) Mount the band switch and coil assembly (#163-2) at FD. Refer to Detail 5B and use a control lockwasher, control flat washer, and control nut. Position the free leads so they may be connected as shown in Pictorial 5.
- ( ) Turn the band switch shaft fully counter-clockwise. The flat portion of the shaft should be opposite panel marking A. If necessary, reposition the switch and re-tighten the control nut.
- ( ) Bend lugs 1, 2, and 4 of the tuning capacitor down so that the lugs are at right angles to the capacitor.
- ( ) Connect the long heavy lead of band F oscillator coil to lug 2 (NS) and the short heavy lead to solder lug 6 of tuning capacitor G (S-1). Position the coil with approximately 1/2" of space between the coil and the chassis.
- ( ) Connect a 4.7  $\mu$ mf N750 tubular ceramic capacitor from lug 8 of tube socket V2 (NS) to the tap on coil F (S-1). Position the body of the capacitor against the tuning capacitor frame.

- ( ) Connect a 2.2  $\mu\mu\text{f}$  (red-red-white) molded phenolic capacitor from lug 4 of tuning capacitor G (S-1) to lug 8 of tube socket V2 (S-3).
- ( ) Place a 2-1/4" length of sleeving on the bare wire connected to the tap on coil F. Connect the free end of this wire to lug 8 of tube socket V1 (S-1). Position the wire above coil F and away from the tuning capacitor.
- ( ) Locate the free end of the ground wire which is connected to all five coils on switch FD.
- ( ) Connect this ground wire to solder lug 5 on tuning capacitor G (S-1).
- ( ) Place a 1" length of sleeving over the remaining free wire coming from the front wafer (lug 1) of switch FD. Connect this wire to lug 1 of tuning capacitor G (NS).
- ( ) Connect a 47  $\mu\mu\text{f}$  mica capacitor from lug 1 of tuning capacitor G (S-2) to lug 2 of tube socket V1 (S-3).

NOTE: The lugs on the rear wafer of switch FD will be wired in the following four steps.

- ( ) Connect the free end of the bare wire coming from lug 1 of switch FD to lug 3 of tube socket V1 (S-1).
- ( ) Connect a 2" wire from lug 1 of tube socket V1 (S-2) to lug 3 of switch FD (S-1).
- ( ) Place a 1/2" length of sleeving on one lead of a 33 K $\Omega$  (orange-orange-orange) resistor. Connect this lead to lug 4 of switch FD (S-1), and connect the other lead to lug 1 of terminal strip L (S-4).
- ( ) Connect a 2-1/2" wire from lug 6 of tube socket V1 (S-2) to lug 5 of switch FD (S-1).

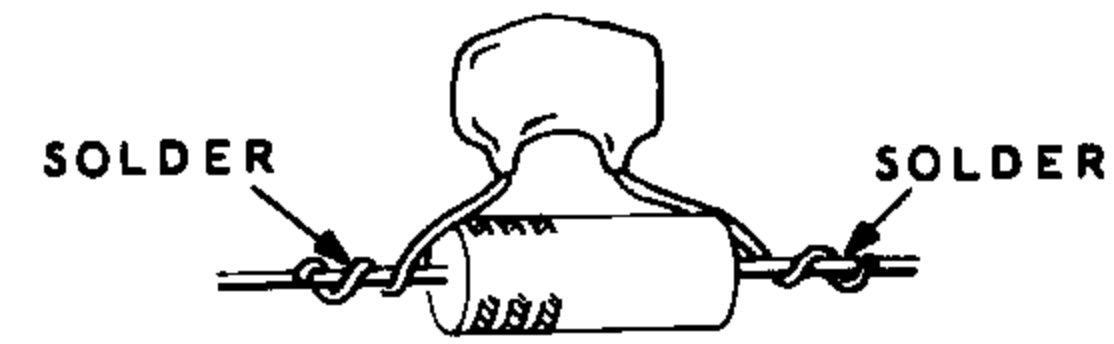

Detail 5C

- ( ) Prepare a 22  $\mu\mu\text{f}$  mica capacitor and 33 K $\Omega$  (orange-orange-orange) resistor combination. See Detail 5C.
- ( ) Connect this capacitor-resistor combination from lug 2 of tuning capacitor G (S-2) to lug 7 of tube socket V1 (S-1).
- ( ) Insert the free end of the line cord through hole U in the rear flange of the chassis.

The line cord wires will be connected to terminal strip S in the following two steps.

- ( ) Either wire to lug 2 (S-3).
- ( ) Other wire to lug 4 (S-3).

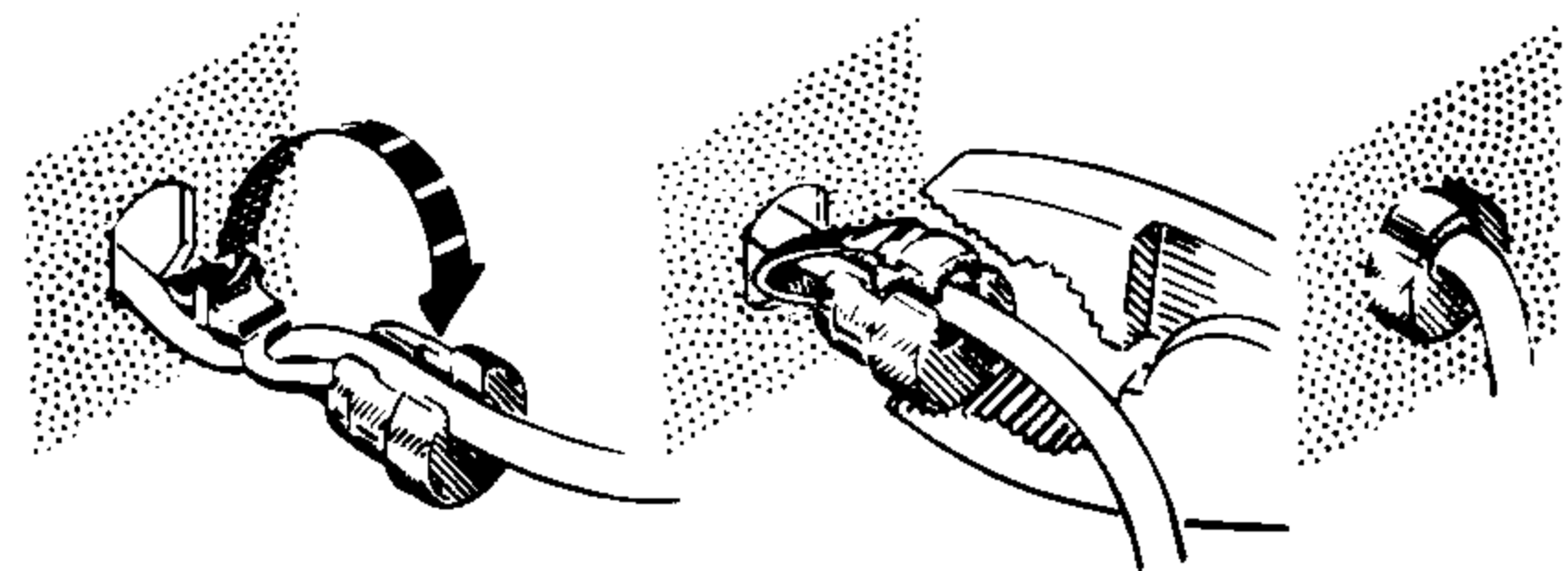

Detail 5D

- ( ) Refer to Detail 5D and install the line cord strain relief at U.

This completes the wiring on the chassis. Carefully check to be sure there are no unsoldered connections, loose or broken leads, or shorted lugs of tube sockets. Turn the chassis over and shake out any bits of solder or wire clippings. Note that one lug on terminal strip S is not used. This extra lug is provided for special wiring in Signal Generators that are shipped abroad.

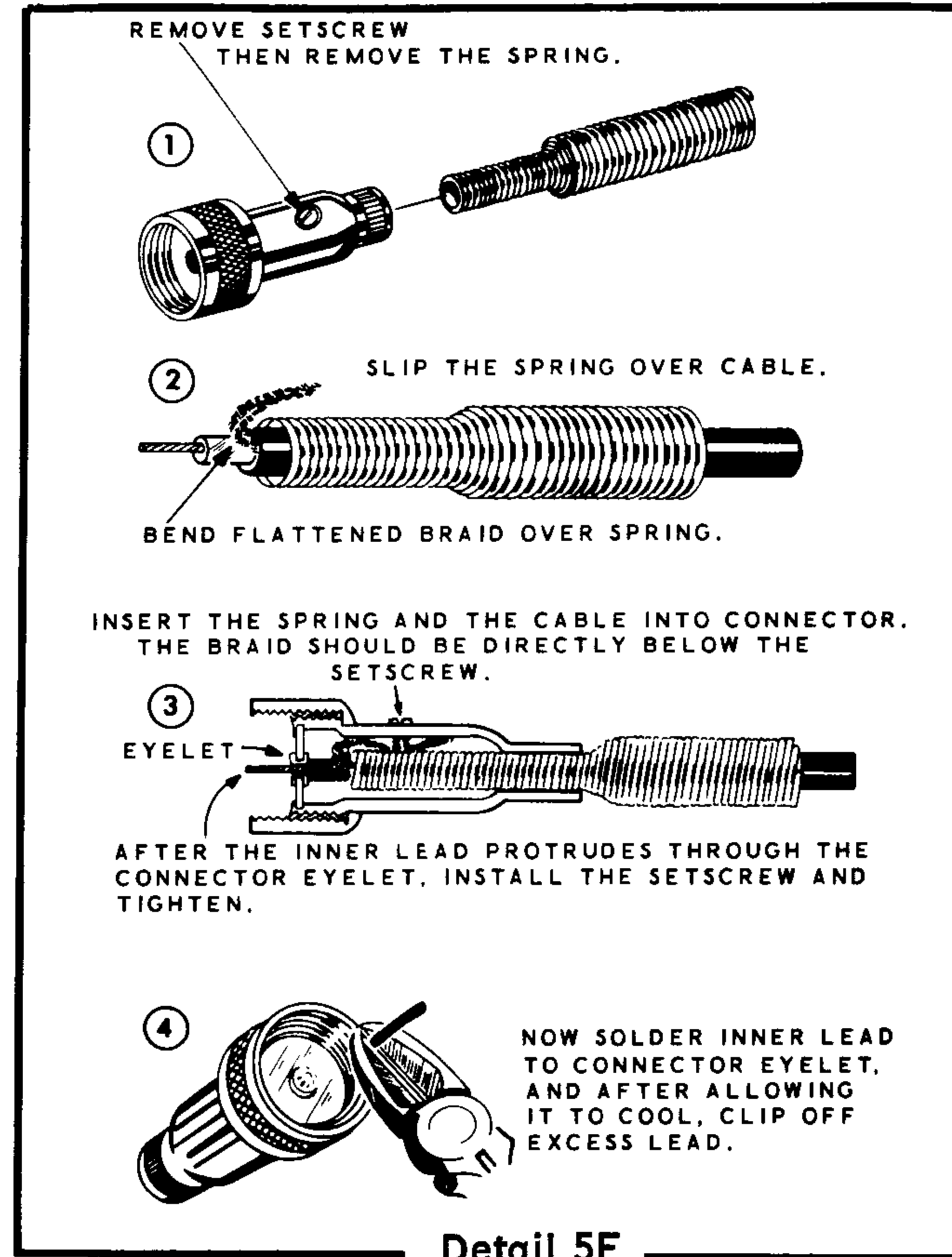
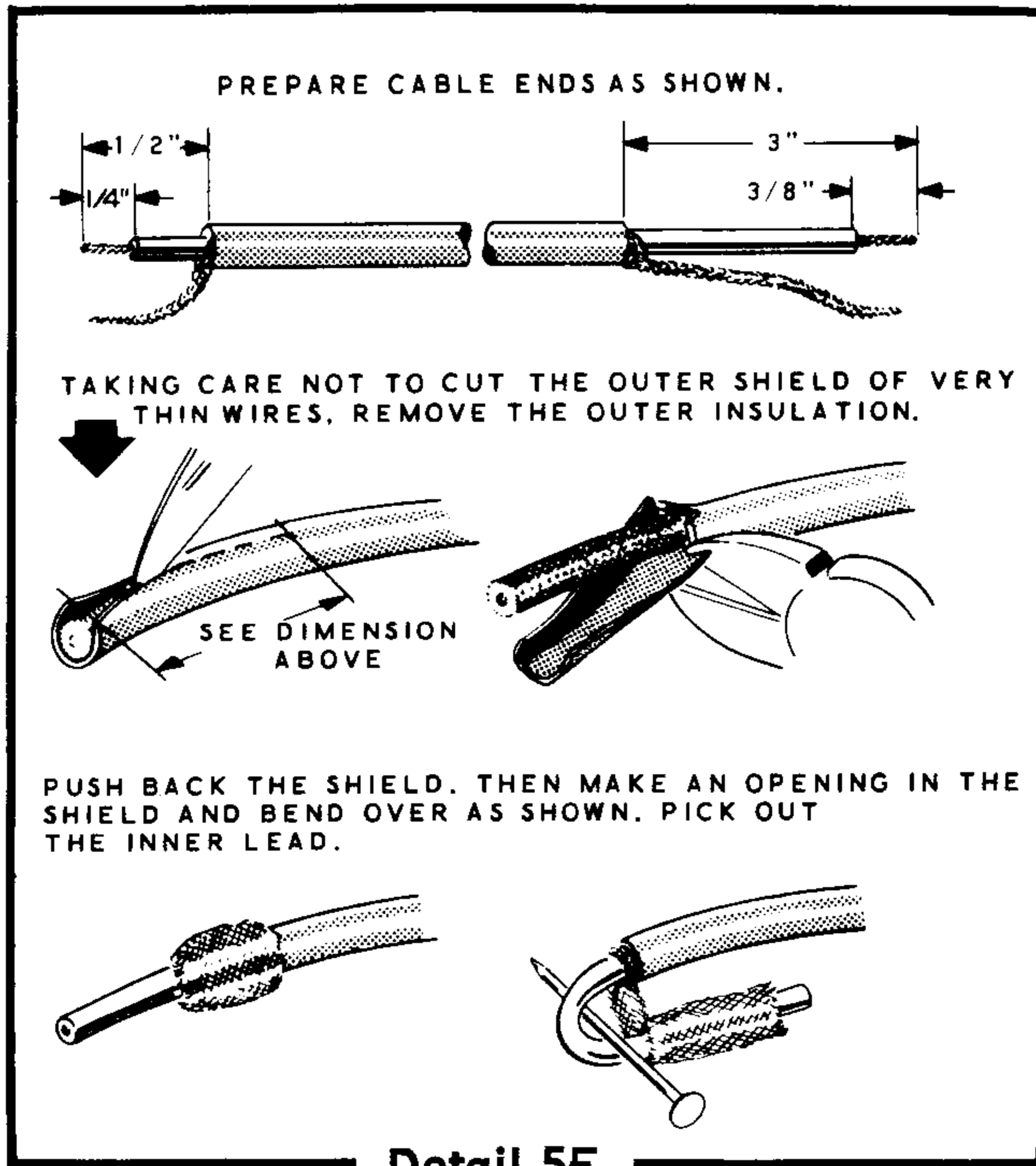

- ( ) Refer to Detail 5E and prepare the length of RG-58A/U coaxial cable.
- ( ) Install a cable connector on the end of this cable that has 1/2" of outer insulation removed. See Detail 5F.
- ( ) Refer to Detail 5G and install two alligator clips on the other end of the cable.

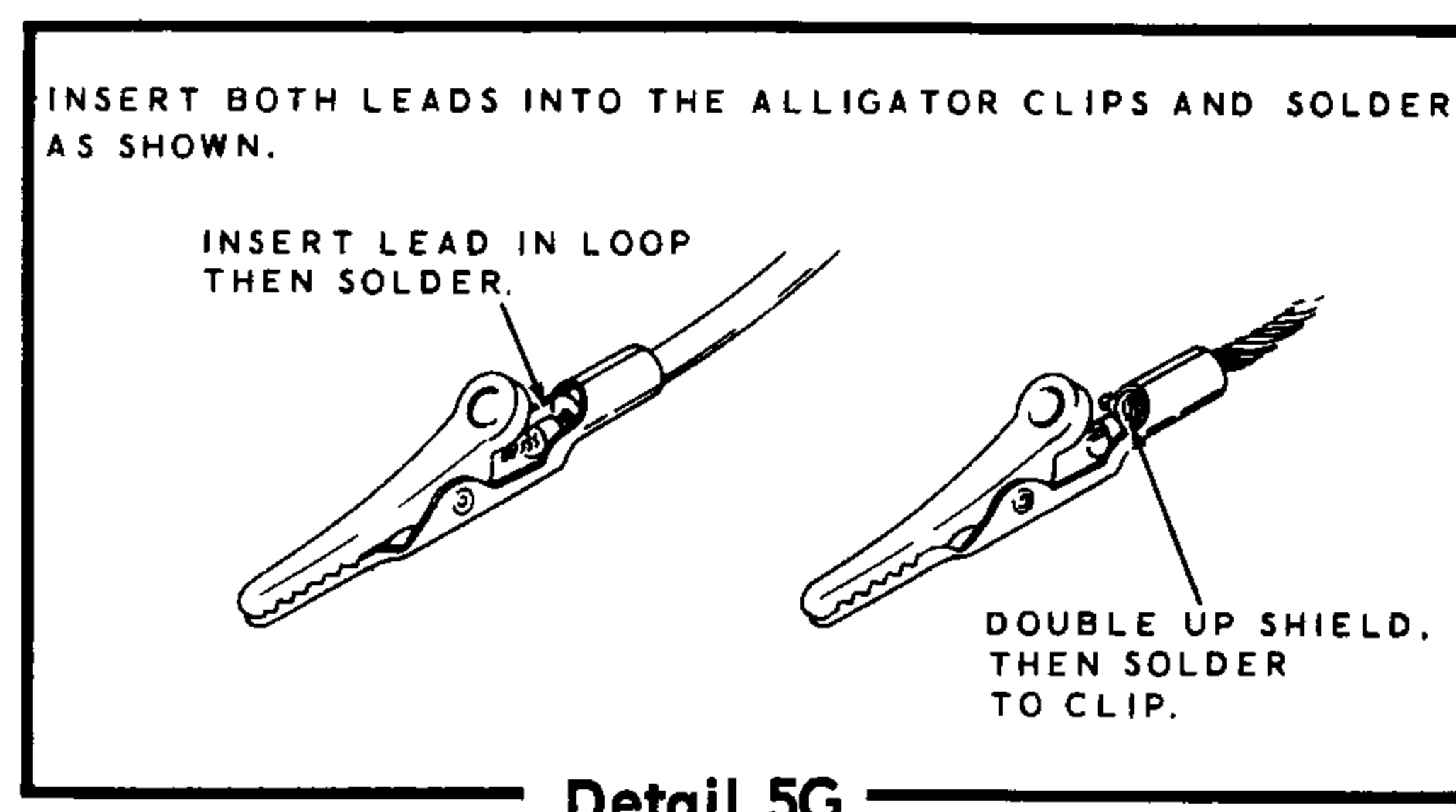

## KNOB AND TUBE INSTALLATION

Refer to Pictorial 6 for the following steps.

- ( ) Turn the shaft of the tuning capacitor fully clockwise.
- ( ) Install the dial pointer assembly on the large shaft of the tuning capacitor. Use an 8-32 setscrew.
- ( ) Turn the shaft of the tuning capacitor fully counterclockwise and be sure the dial pointer lines up with the end marking at the low end of the dial. See Detail 6A. If necessary, reposition the dial pointer assembly and tighten the setscrew securely. Also, be sure the dial pointer does not rub against the front panel as the tuning shaft is turned.

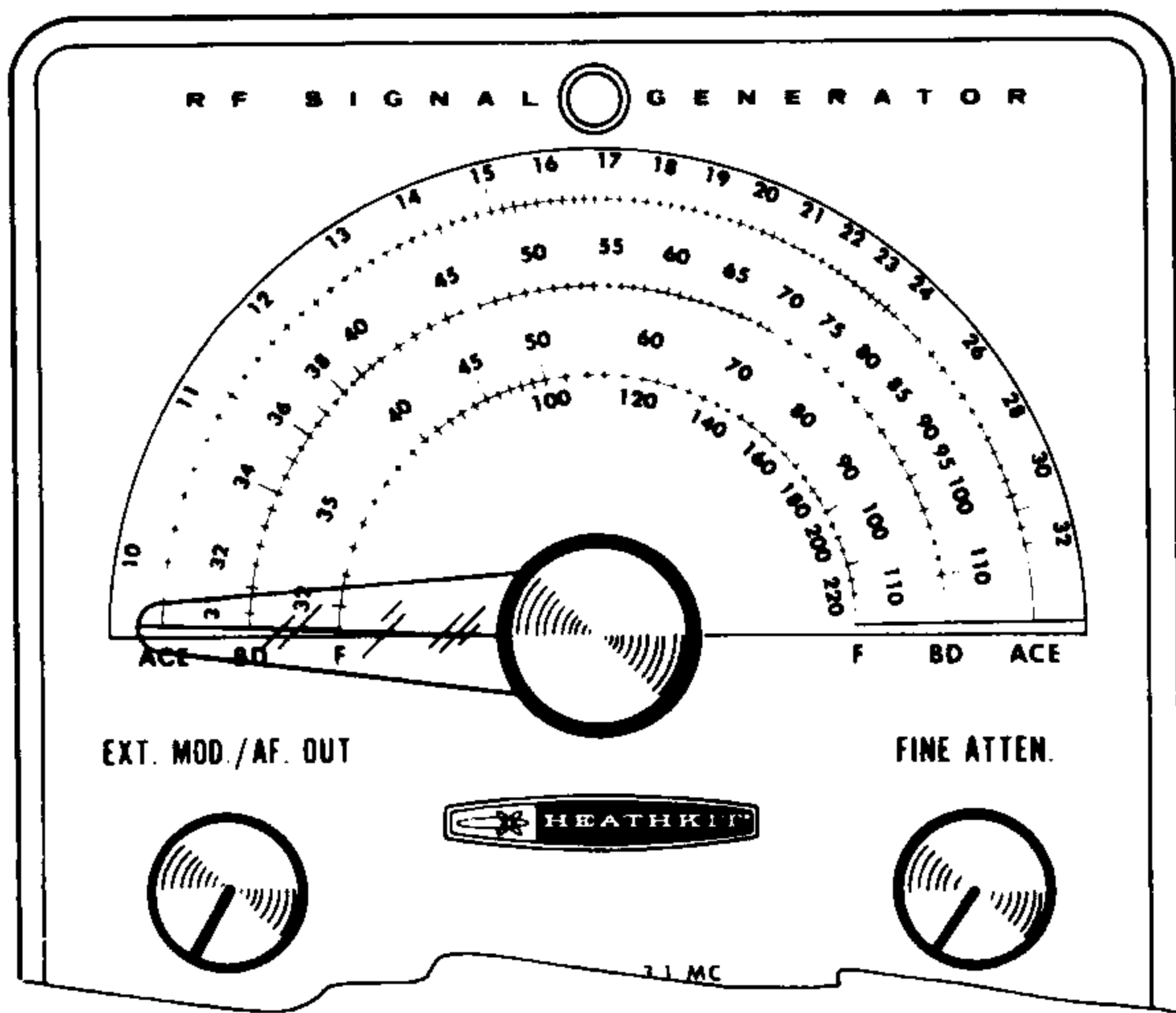

Detail 6A

- ( ) Install the large knob on the small shaft of the tuning capacitor.
- ( ) Install the pointer knobs on the remaining control shafts. Position the knobs so the index markers are as shown in the Pictorial, with all control shafts turned fully counterclockwise.
- ( ) Refer to Pictorial 7 and install a 12AT7 tube in tube socket V1.
- ( ) Install a 6AN8 tube in tube socket V2.

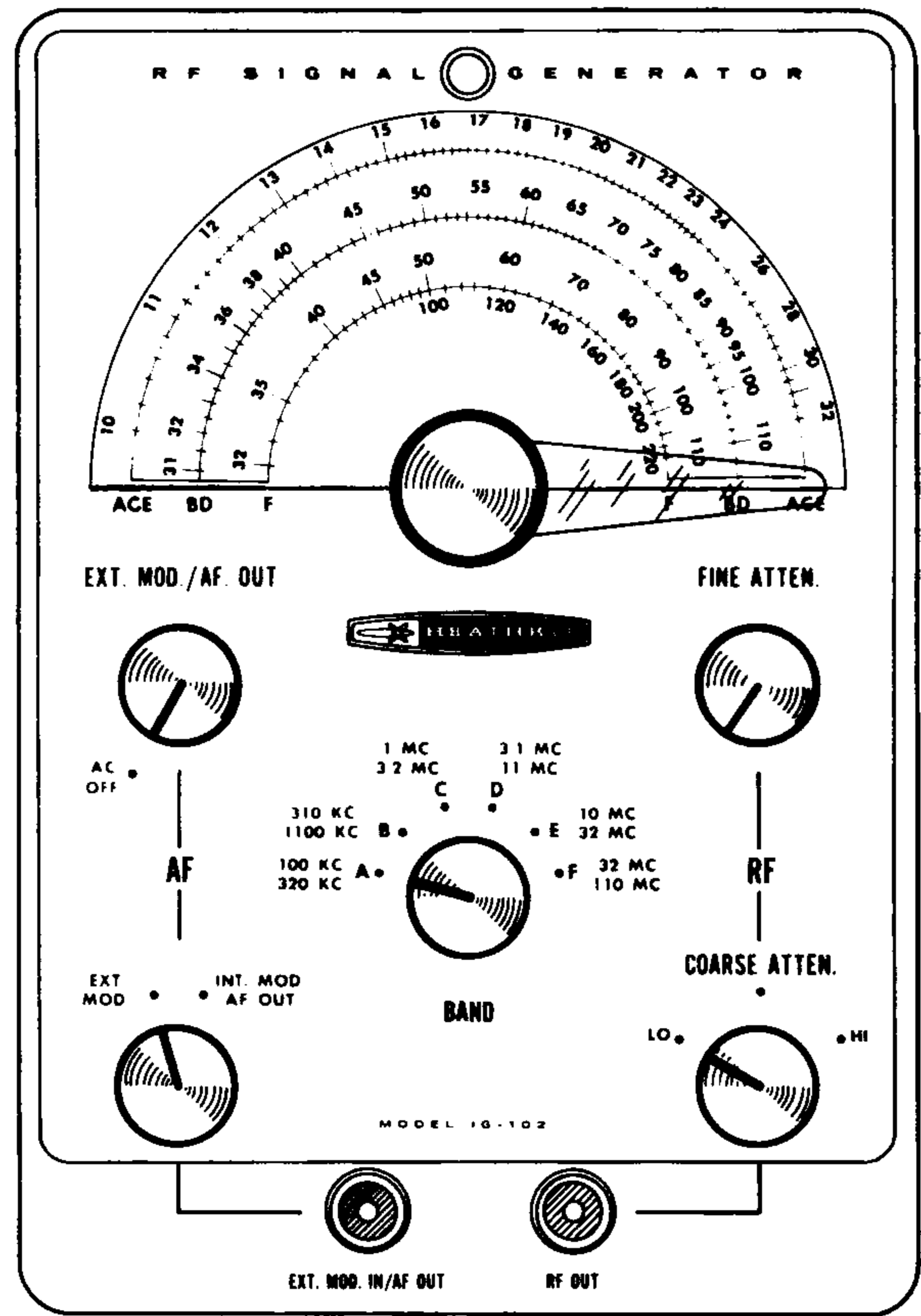

PICTORIAL 6

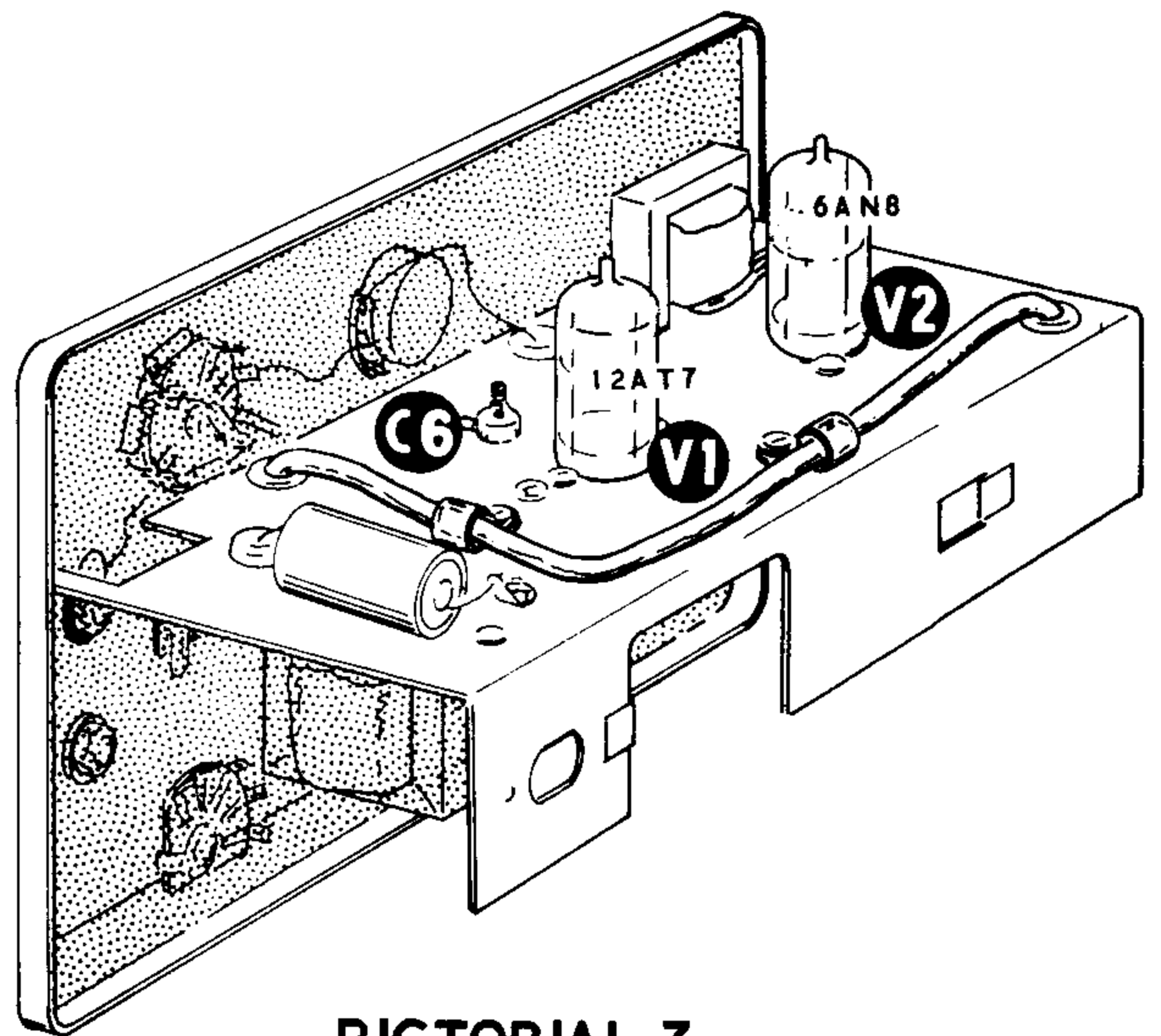

PICTORIAL 7

## INITIAL TEST

If an ohmmeter is available, check for possible short circuits in the power supply before applying power to the Signal Generator for the first time. If an ohmmeter is not available, proceed to the Note which follows the next three steps.

Refer to Pictorial 4 (fold-out from Page 14) for the next three steps.

- ( ) Place the ohmmeter range switch in the RX1000 position.
- ( ) Connect the test leads of the ohmmeter across the leads of the silicon diode connected between lugs 2 and 4 of terminal strip L. Then note the resistance reading. The initial kick of the meter pointer indicates that the filter capacitors are charging. Reverse the ohmmeter leads to the diode and note the reading. The ratio of the two resistance readings should be 10 to 1 or greater.
- ( ) To check the B+ supply circuit, connect the common (negative) test lead of the ohmmeter to the chassis and the ohms (or "hot") test lead to lug 1 of terminal strip L. The meter pointer should kick down to a fairly low reading, indicating charging of the

filter capacitors, and then rise slowly to a reading of at least 50,000  $\Omega$ . If a reading of less than 50,000  $\Omega$  is obtained, reverse the test leads and check again. Then check the installation of the silicon diode and be sure the cathode lead is connected to lug 4 of terminal strip L. Refer to Detail 4B on Page 15 to identify the cathode lead of the diode. If you are still unable to obtain a resistance reading of 50,000  $\Omega$ , refer to the In Case Of Difficulty section of the manual.

NOTE: If the proper results are not obtained in the following steps, turn the Generator off and refer to the In Case Of Difficulty section of the Manual.

- ( ) Plug the line cord into a standard (105 to 125 volts, 50/60 cps) AC outlet.
- ( ) Turn the EXT MOD/AF OUT control clockwise to turn the Generator on. The tube filaments and pilot lamp should light.
- ( ) Visually check all parts for any signs of overheating.
- ( ) Proceed to the Calibration section.

## CALIBRATION

Before starting the Generator calibration, carefully study the operation of each control and switch as described in Figure 2 on Page 23.

An AM radio is needed to calibrate bands A, B, C, D, and E. The tuned circuit and component parts for band F have been preadjusted at the factory. If additional accuracy is desired, an FM radio must be used to calibrate band F.

### BANDS A THROUGH E

- ( ) Turn the BAND switch to band B.
- ( ) Turn the Modulation switch to EXT MOD.
- ( ) Turn the FINE ATTEN control fully clockwise.
- ( ) Set the COARSE ATTEN switch at HI.
- ( ) Connect the shielded output cable to the Generator RF OUT connector. Place the free end of this cable near the loop or antenna lead of the AM radio, but do not connect it directly to the radio.
- ( ) Turn the Generator and AM radio on. Allow the Generator and radio to warm up for 15 minutes so all components will reach normal operating temperature.

The following procedure will be used to calibrate the Generator.

First, a signal of known frequency is tuned in on the AM radio. Then the dial pointer of the Generator is set to the exact frequency of the station the radio is tuned to. The RF oscillator is then tuned to the same frequency as the radio station by adjusting it until a zero beat is heard in the radio.

This zero beat is the signal that is created by the beating together of the oscillator signal and the station signal in the radio. When the beat is heard, it starts out as a high pitched tone, which gradually changes as the beat frequency becomes lower until the tone becomes very low pitched. Once the zero beat point is passed, the tone gradually increases in pitch until it can no longer be heard.

At these frequencies it is often hard to get a complete zero beat (no sound at all) between the signals. Often, a low pitched tone or a slow popping sound will be as close as you will be able to come to a complete zero beat. The output level of the Generator should be just high enough to give a clear beat sound; do not set the Generator output level higher than necessary.

- ( ) Locate the alignment tool blade supplied with this kit. Refer to Figure 1 and use a pair of long-nose pliers. Insert the blade into the smaller hole of the nut starter until the blade end is flush with the end of the nut starter. This now can be used as a trimmer alignment tool.

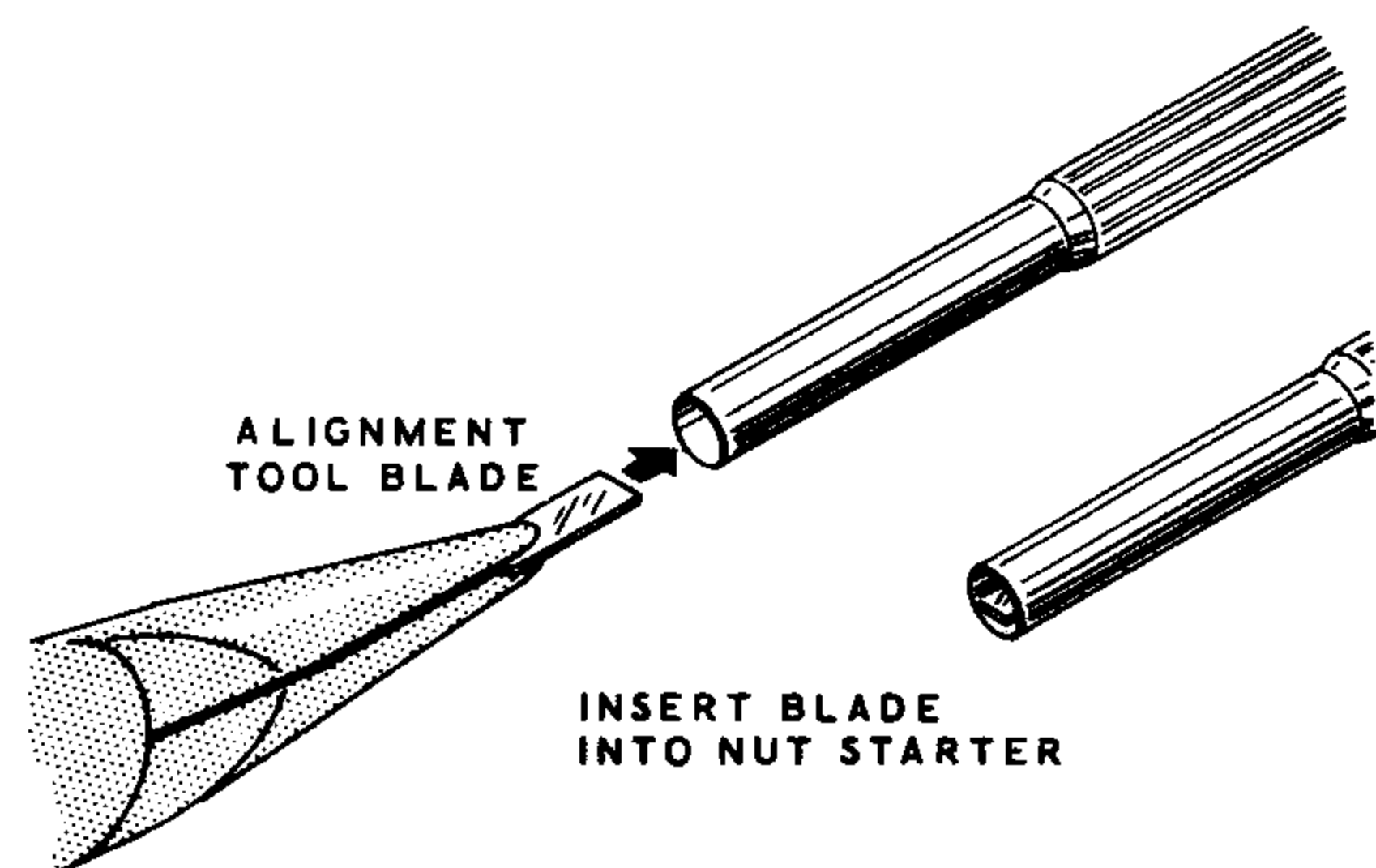

Figure 1



- ( ) Referring to Pictorial 7 (Page 18) and using the trimmer alignment tool, preset trimmer capacitor C6 until the top of the adjustment screw is 1/2" above the chassis.
- ( ) Tune the AM radio to a station of known frequency between 800 and 1000 kc. The frequency of this station should preferably be one whose frequency falls directly on one of the calibration points on the dial, such as 800 kc, 850 kc, 900 kc, or 1000 kc.
- ( ) Turn the dial pointer on the Generator to the place on the dial that indicates the exact frequency of the station the radio is tuned to.
- ( ) Adjust trimmer capacitor C6 for a zero beat in the radio. Use the FINE ATTEN and COARSE ATTEN controls to set the output level of the Generator just high enough to give a clear zero beat in the radio.

This completes the calibration of bands A through E. Turn off the AM radio.

The frequencies, for bands A through E, were adjusted with trimmer capacitor C6. This was possible because the adjustment slug, for each coil on these bands, was accurately adjusted at the factory. A slight improvement in accuracy could be obtained if the slug in each coil was adjusted by zero beating the Generator signal with an accurate frequency standard. An accurate frequency standard could be obtained by tuning a communications receiver to a WWV frequency such as 2.5 mc, 5 mc, 10 mc, etc., (National Bureau of Standards). Standard frequencies can also be obtained from a precision laboratory generator (with an accuracy of at least 1%), in conjunction with an oscilloscope to indicate the zero beat. If the coil slugs are adjusted, each band should be adjusted near the low end of the dial. A coil alignment tool, for adjusting the coil slugs, is supplied with the kit.

## BAND F

To calibrate band F to obtain additional accuracy, you must use an FM radio.

- ( ) Turn on the FM radio and tune it to a station between 88 mc and 100 mc.
- ( ) Set the BAND switch to band F, and turn the dial pointer to the frequency of the FM station.
- ( ) Turn the Modulation switch to INT MOD/AF OUT.
- ( ) Connect the output cable of the Generator to the antenna terminals of the FM radio.
- ( ) Turn the Generator dial pointer back and forth and listen for the 400 cps tone modulation in the FM radio. This 400 cps tone will be weakest at the correct frequency, and it will be louder on both sides of this frequency.
- ( ) Turn the Generator dial pointer to the place where the 400 cps tone is weakest. If the dial indicator points to a frequency lower than the station frequency, gently squeeze together the turns of coil F. Then retune the dial pointer to the weakest 400 cps tone. Repeat this procedure until the correct frequency is indicated on the Generator dial. See Pictorial 5 to identify coil F. If the dial pointer indicates a higher frequency than the station frequency, the turns of coil F should be spread apart slightly.

This completes the calibration of band F.

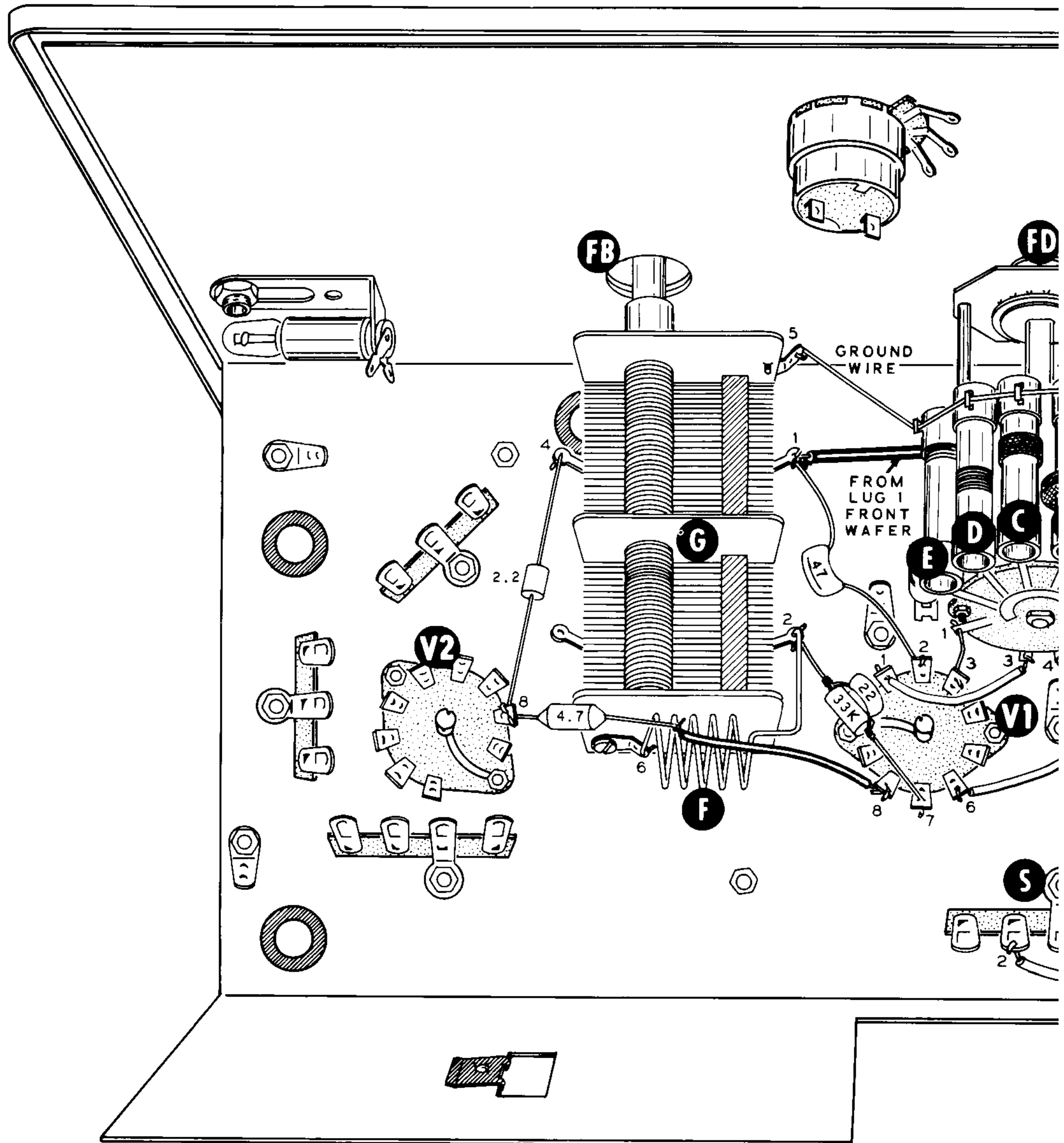

**PICTORIAL 5**



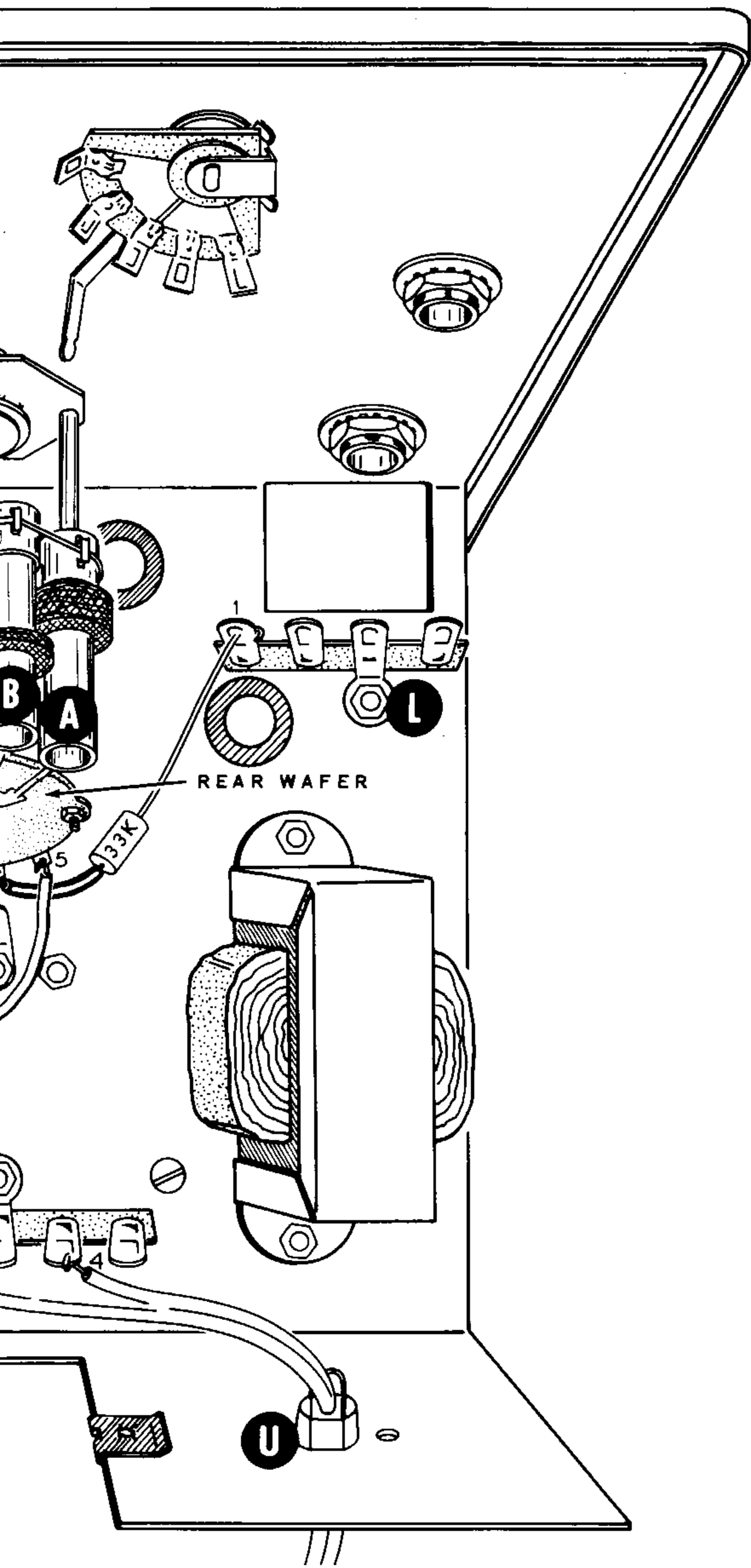

## FINAL ASSEMBLY

Refer to Pictorial 8 for the following steps.

- ( ) Prethread both holes in the handle using a #10 sheet metal screw.
- ( ) Mount the handle on the top of the cabinet. Use #10 sheet metal screws.
- ( ) Insert the line cord through the large hole in the back of the cabinet, then install the Generator in the cabinet with two #6 x 3/8" screws.

NOTE: The blue and white identification label shows the Model Number and Production Series Number of your kit. Refer to these numbers in

any communications with the Heath Company; this assures you that you will receive the most complete and up-to-date information in return.

- ( ) Install the identification label in the following manner:
  1. Select a location for the label where it can easily be seen when needed, but will not show when the unit is in operation. This location might be on the rear panel or the top of the chassis, or on the rear or bottom of the cabinet.
  2. Carefully peel away the backing paper. Then press the label into position.

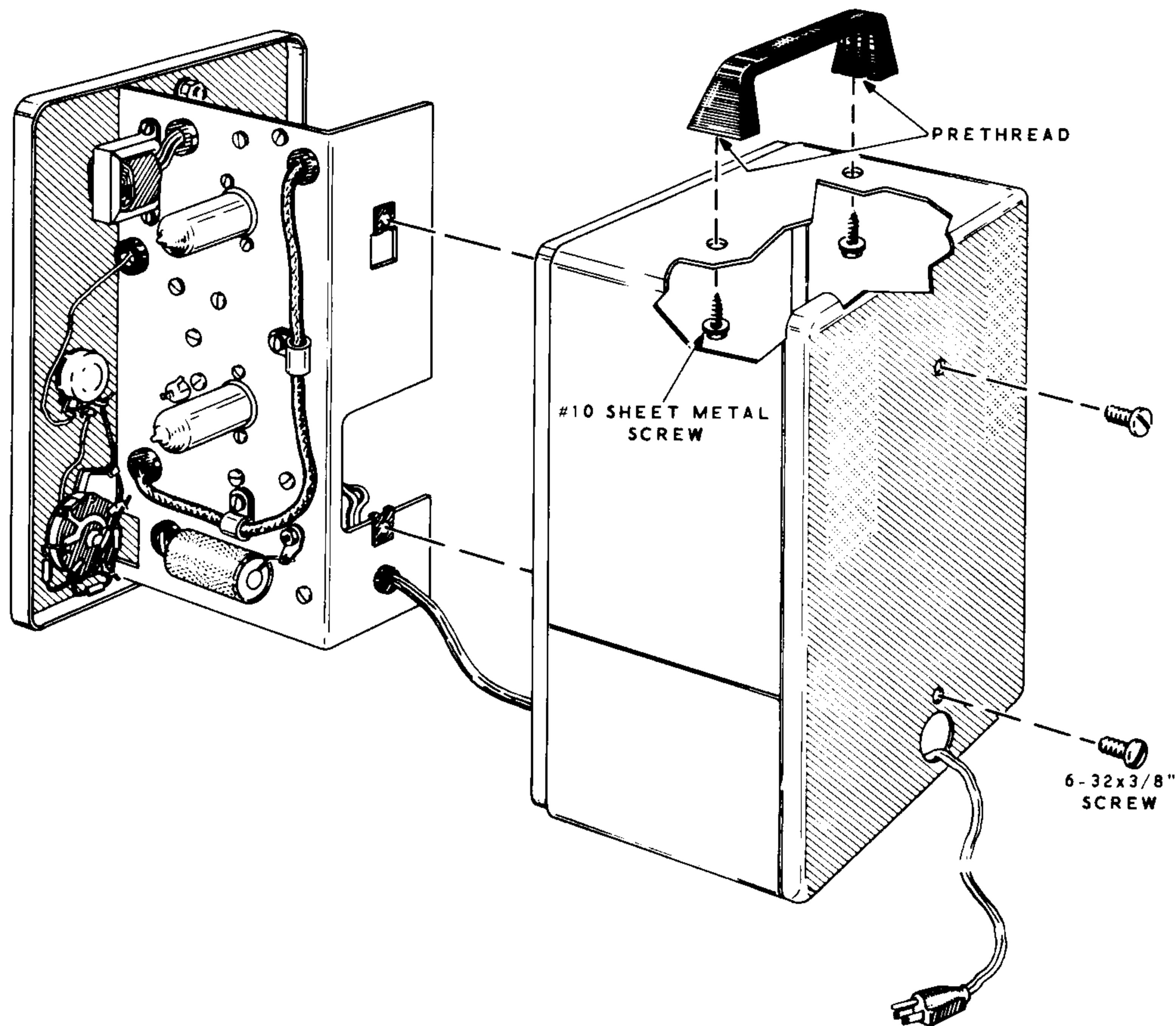

PICTORIAL 8

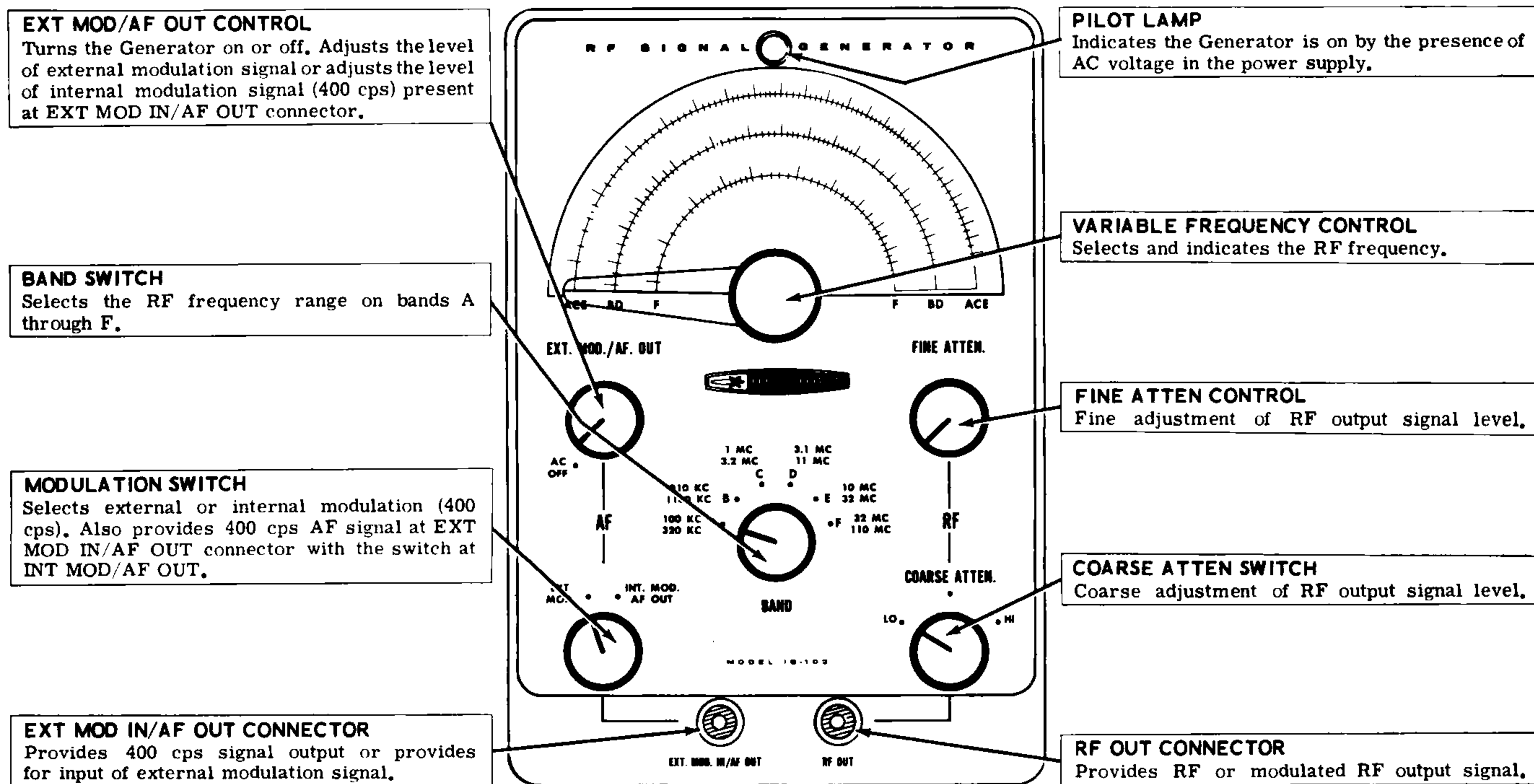

Figure 2

## OPERATION

Figure 2 explains the basic functions of the front panel controls. A detailed explanation of how to read the dial scale, and the use of some front panel controls, is given in the following paragraphs.

### DIAL SCALE

The RF output frequency of the Generator depends on the number the dial pointer is set to, and the position of the BAND switch. Bands A, C, and E are read on the outside dial scale, bands B and D are read on the center dial scale, and band F is read on the inside dial scale. See Figure 3.

Proceed as follows to read the dial scales. On bands A and B, multiply the number indicated on the dial by 10 to obtain the frequency in kc. On bands C and D, divide the number indicated on the dial by 10 to obtain the frequency in mc. On bands E and F, the dial is read directly in mc. Refer to the inset drawing on Figure 3 and the following table for examples of how to read the dial scale.

| BAND | DIAL READING        | FREQUENCY |
|------|---------------------|-----------|
| A    | 23 (multiply by 10) | 230 kc    |
| B    | 75 (multiply by 10) | 750 kc    |
| C    | 23 (divide by 10)   | 2.3 mc    |
| D    | 75 (divide by 10)   | 7.5 mc    |
| E    | 23 (read direct)    | 23 mc     |
| F    | 77 (read direct)    | 77 mc     |

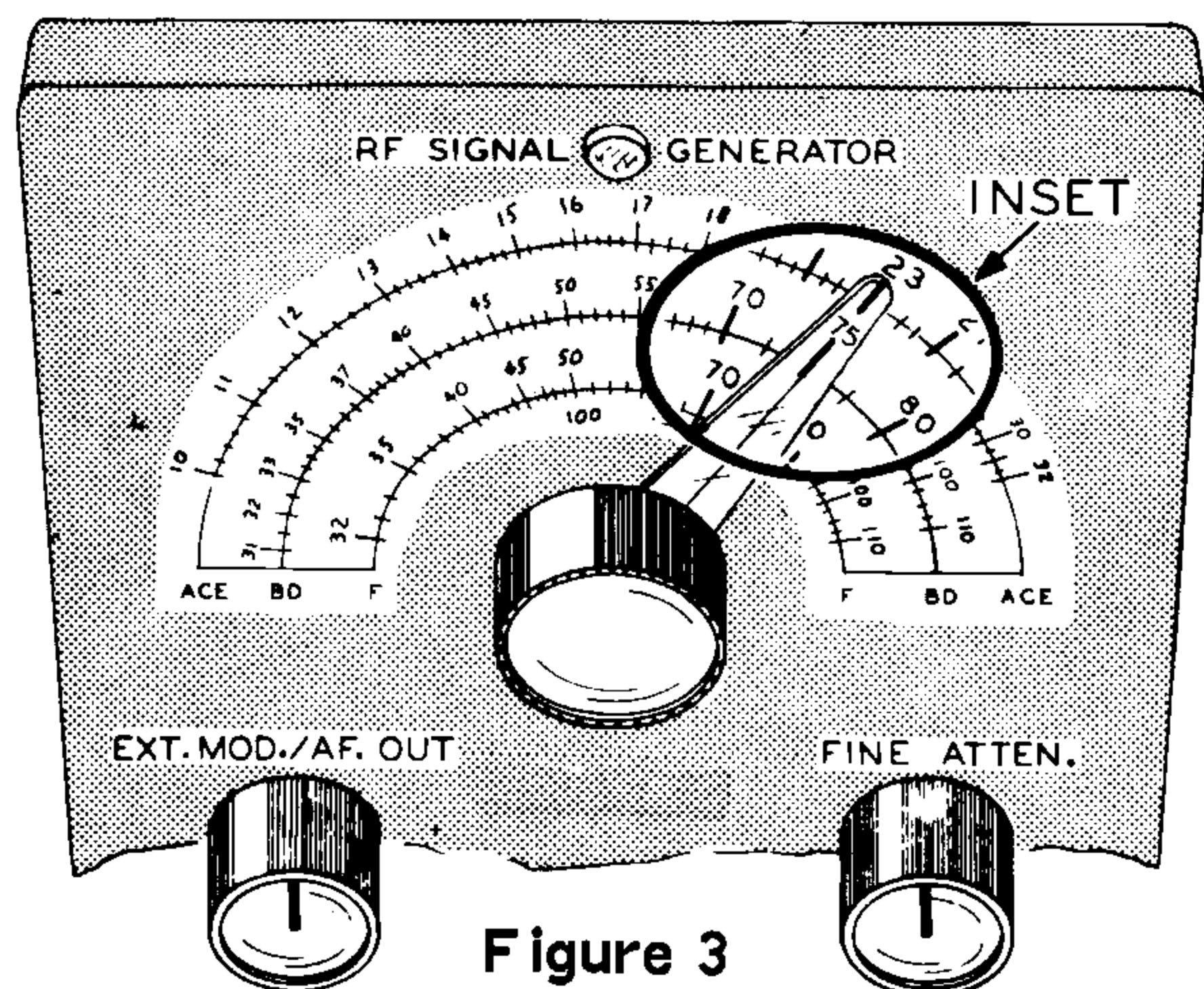

Figure 3

The numbers from 100 to 220 on the inside of scale F are calibrated harmonic frequencies of band F. This dial scale, which should be read directly, adds another range of frequencies from 100 mc to 220 mc. The most commonly used IF frequencies for AM and FM radio receivers are indicated with a special mark on the dial; 455 kc (AM) is marked on band B and 10.7 mc (FM) is marked on band E.

## GENERAL

When the Modulation switch is turned to INT MOD/AF OUT, a 400 cps audio signal is available at the connector marked EXT MOD IN/AF OUT. With this switch turned to EXT MOD, the

internal 400 cps oscillator is turned off, and the RF signal may be modulated by connecting an external audio signal to the EXT MOD IN/AF OUT connector. An audio signal with a level of about 3 volts is needed for 30% modulation of the RF frequency.

## APPLICATIONS

The RF Signal Generator may be used as an RF signal source for the peak alignment of tuned circuits in some FM radios and tuners. More often, though, the sweep alignment method is used to align high quality FM radios and tuners. For sweep alignment, an RF sweep generator is needed and your RF Signal Generator may be used as a marker generator. Whenever possible it is best to follow the detailed instructions from the manufacturer of the FM radio or tuner.

There are many other applications for this Generator which are too numerous to outline in this Manual. However, two basic applications are outlined here under AM Radio Alignment and Signal Injection.

### AM RADIO ALIGNMENT

Figure 4 shows a block diagram of a typical AM radio. This diagram includes all of the circuits that must be aligned. The radio speaker or a suitable voltmeter may be used as the output indicator. However, a voltmeter will indicate smaller changes in the output signal and is more desirable.

If a DC voltmeter is used, set it to measure negative DC volts, and connect it to the output of the AVC filter circuit as shown. If an AC voltmeter is used, it may be connected between the two outside lugs of the volume control or across the speaker terminals.

Be sure to use the proper frequency for alignment of the IF transformers. An IF frequency of 455 kc will be used in the following procedure, since it is used in most AM radios. But your

radio may use another IF frequency such as 262 kc or 460 kc. Follow the detailed instructions from the manufacturer of the radio whenever possible.

1. Turn on the radio, RF Signal Generator, and voltmeter if one is used. Allow the equipment to warm up for 15 minutes so that all components will reach normal operating temperature.
2. Turn the AM radio dial to the high frequency end of the dial.
3. Connect the output cable to the connector labeled RF OUT on the Signal Generator.
4. If the radio uses a loop or rod antenna, place the inner or "hot" lead of the output cable near the antenna. If there is no loop or rod antenna, connect the hot lead of the output cable to the antenna terminal and the shield lead to the chassis of the radio.
5. Set the Signal Generator to 455 kc (Band B) and the Modulation switch to the INT MOD/AF OUT position.
6. Use an insulated alignment tool to adjust the IF transformers which are shown in the shaded portions of Figure 4. Start with the last IF transformer (next to the detector stage) and work toward the first; adjust each one for a maximum reading on the voltmeter or the loudest signal from the speaker. At the same time, reduce the Signal Generator output to keep the output of the radio at minimum but still large enough to give an indication on the voltmeter.

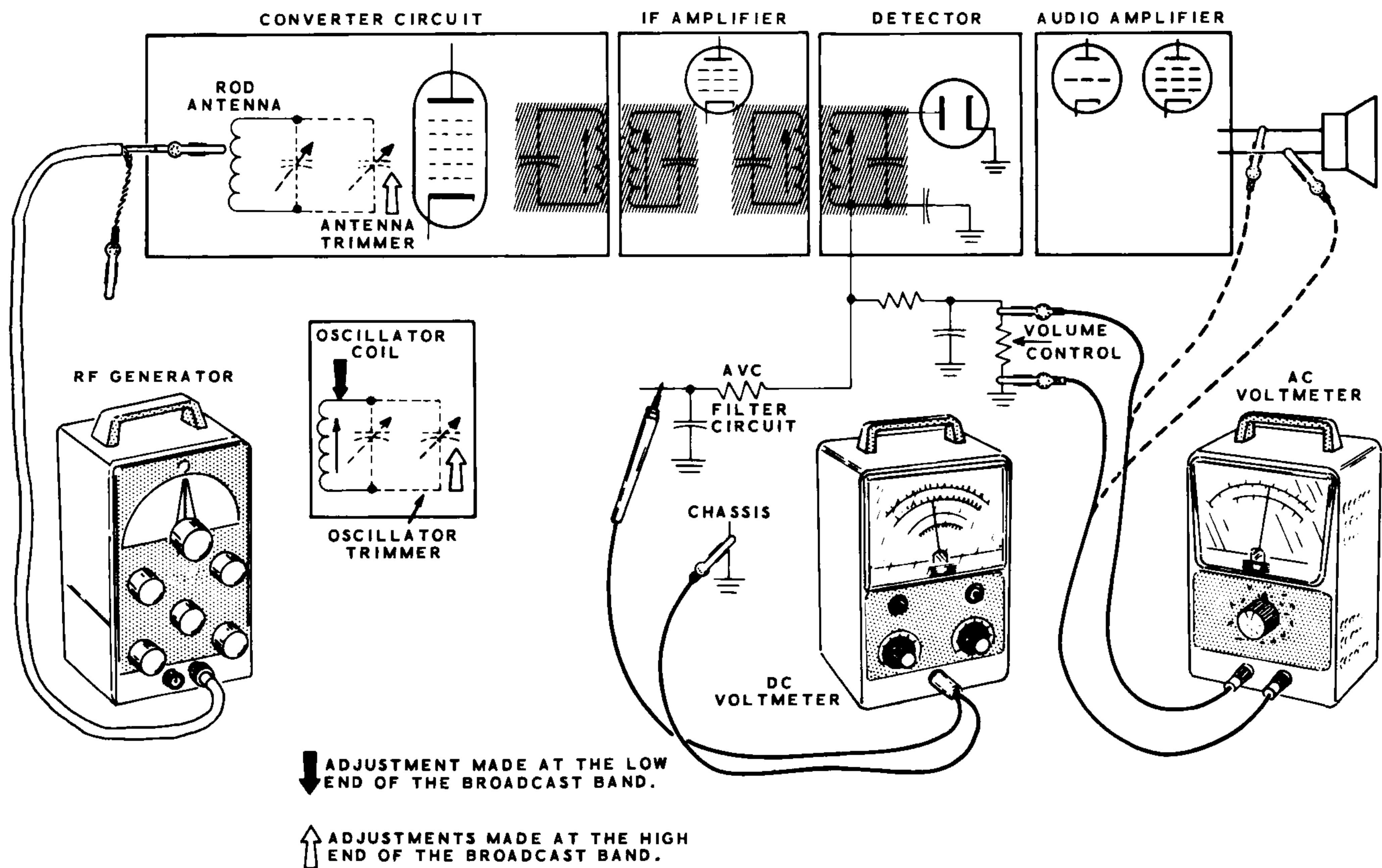

Figure 4

7. Since the IF adjustments affect each other, repeat the adjustments at least once for best results.
8. Set the Signal Generator and radio to 1600 kc. Adjust the oscillator trimmer capacitor (shown by light arrow in Figure 4) for maximum voltage reading.
9. Set the Signal Generator and radio to 1400 kc. Adjust the antenna trimmer capacitor (also shown by light arrow) for maximum voltage reading.
10. Set the Signal Generator to 600 kc and tune the AM radio to 600 kc.
11. Adjust the slug of the oscillator coil (shown by the dark arrow) for maximum reading on the voltmeter. Now tune the radio a slight

amount in either direction so the signal sounds faint or the voltage reading decreases slightly. Again adjust the oscillator coil for maximum voltage, then note whether the voltage is larger or smaller than it was before. Retune the radio a slight amount again, in the same direction if the voltage increased, and in the other direction if the voltage decreased, and adjust the oscillator coil for maximum voltage. Repeat this retuning and coil adjustment process until you locate the oscillator coil adjustment that produces the largest reading on the voltmeter.

12. Repeat steps 8 through 11 again because there will be some interaction between the adjustments.

This completes the alignment of the AM radio.

## SIGNAL INJECTION

Signal injection is a technique used to troubleshoot weak or dead electronic devices (radio and TV receivers, hi-fi amplifiers, etc.), to find the circuit that is not operating properly. In this method, a signal is coupled into the stages of the defective equipment, one stage at a time, until the defective stage is located.

A coupling capacitor (.05  $\mu\text{fd}$ ) should always be used with the hot lead to keep DC voltages from being connected to the Signal Generator. Also, care should be used so the test signal does not overdrive the stage it is connected to.

For example, this method might be used to find an open coupling capacitor between two amplifier stages. In this case, the signal would be heard when the 400 cps audio signal from the Signal Generator is connected to the control grid of the second tube. This is shown as point G in Figure 5. The signal will not be heard when the Signal Generator is connected to the plate of the first tube (point P).

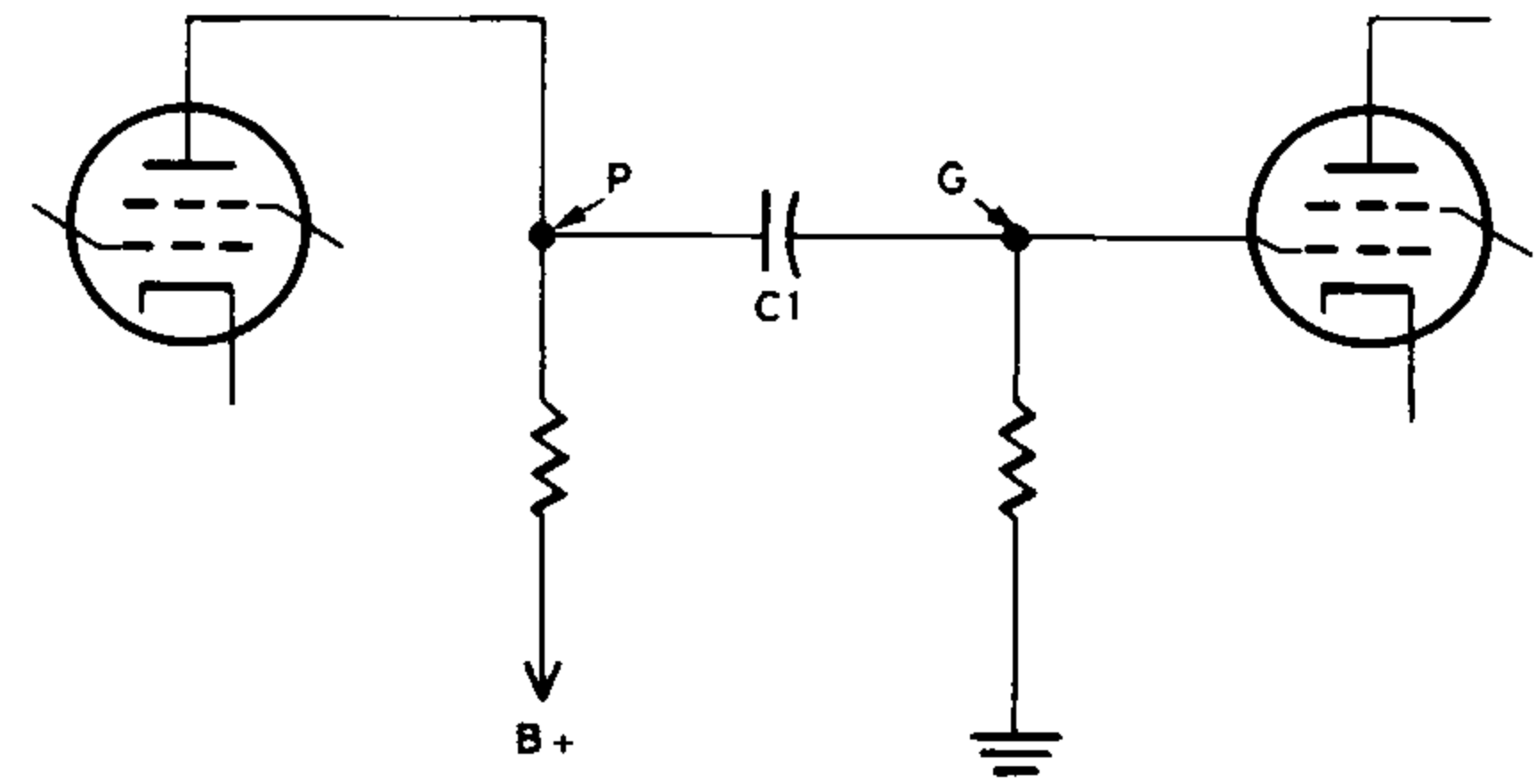

Figure 5

Figure 6 shows how signal injection can be used to find the faulty stage of an AM radio receiver. First the 400 cps audio signal from the Signal Generator is connected to the grid of the output tube, then the hot lead of the Signal Generator is moved back to the audio amplifier tube. If a normal sound is heard from the speaker in both cases, a modulated RF signal would be used to check the remaining stages of the radio. The modulated RF frequencies shown in Figure 6 would be used.

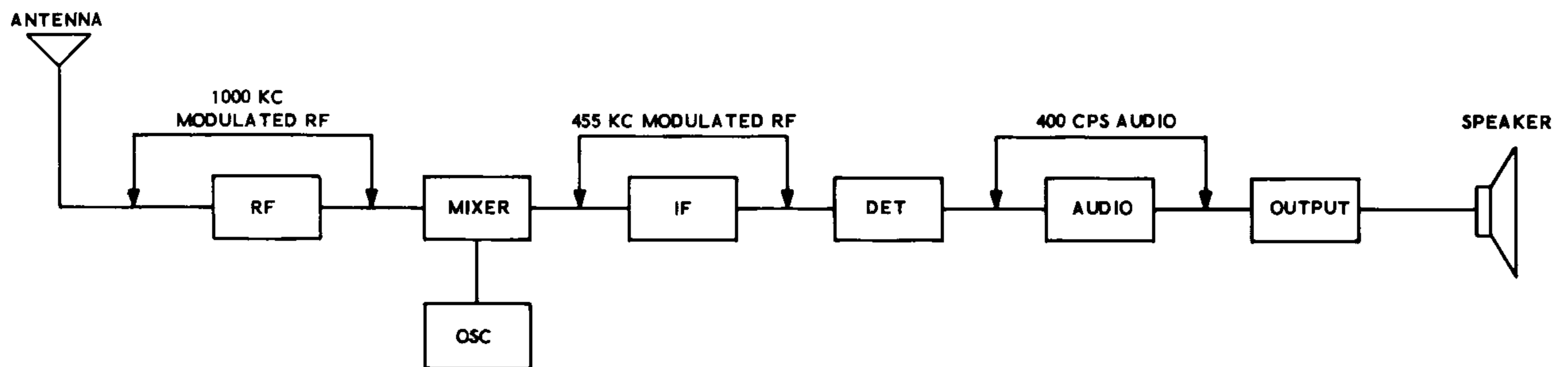

Figure 6

## IN CASE OF DIFFICULTY

If your RF Signal Generator does not operate properly after assembly, use the following information to help locate and correct the difficulty. The Troubleshooting Chart on Page 28 will also help you locate the problem.

1. Recheck the wiring. Trace each lead in colored pencil on the Pictorial as it is checked. It is frequently helpful to have a friend check your work. Someone who is not familiar with the unit may notice something consistently overlooked by the builder.
2. It is interesting to note that about 90% of the kits that are returned for repair do not function properly due to poor connections and soldering. Therefore, many troubles can be eliminated by reheating all connections to make sure that they are soldered as described in the Proper Soldering Techniques section of this manual.
3. Check to be sure that all tubes are in their proper locations. Make sure that all tubes light up properly.
4. Check the tubes with a tube tester, or by substitution of tubes of the same types that are known to be good.
5. Check the values of the parts. Be sure the proper part has been wired into the circuit, as shown in the pictorial diagrams and as called out in the wiring instructions.
6. Check for bits of solder, wire ends or other foreign matter which may be lodged in the wiring.
7. If, after careful checks, the trouble is still not located and a suitable meter is available, check voltage readings against those shown on the Schematic (fold-out from Page 35). NOTE: All voltage readings were taken with an 11 megohm input vacuum tube voltmeter. Voltages and resistances may vary as much as 10%.
8. A review of the Circuit Description will prove helpful in indicating where to look for trouble.

NOTE: In an extreme case where you are unable to resolve a difficulty, refer to the Service and Warranty sections of the "Kit Builders Guide", and to the "Factory Repair Service" information on Page 29 of this Manual.

## TROUBLESHOOTING CHART

| DIFFICULTY                                 | POSSIBLE CAUSE                                                                                                                                                |
|--------------------------------------------|---------------------------------------------------------------------------------------------------------------------------------------------------------------|
| Pilot lamp and tubes do not light.         | <ol style="list-style-type: none"><li>1. Open on-off switch.</li><li>2. Faulty power transformer.</li></ol>                                                   |
| No RF output signal.                       | <ol style="list-style-type: none"><li>1. Check tubes V1 and V2.</li><li>2. Shorted or open output cable.</li></ol>                                            |
| No modulation present on RF output signal. | <ol style="list-style-type: none"><li>1. Check tube V2.</li><li>2. Check wiring of tube socket V2.</li><li>3. Check wiring of modulation switch S3.</li></ol> |
| No B+ voltage.                             | <ol style="list-style-type: none"><li>1. Check diode D1.</li><li>2. Check resistor R17, capacitor C25A, and capacitor C25B.</li></ol>                         |



## FACTORY REPAIR SERVICE

You can return your completed kit to the Heath Company Service Department to have it repaired for a minimum service fee. (Kits that have been modified will not be accepted for repair.) If you wish, you can deliver your kit to a nearby Heath Authorized Service Center. These centers are listed in your Heathkit catalog.

To be eligible for replacement parts under the terms of the warranty, equipment returned for factory repair service, or delivered to a Heath Authorized Service Center, must be accompanied by the invoice or the sales slip, or a copy of either. If you send the original invoice or sales slip, it will be returned to you.

If it is not convenient to deliver your kit to a Heath Authorized Service Center, please ship it to the factory at Benton Harbor, Michigan and follow the following shipping instructions:

Prepare a letter in duplicate, containing the following information:

- Your name and return address.
- Date of purchase.
- A brief description of the difficulty.
- The invoice or sales slip, or a copy of either.
- Your authorization to ship the repaired unit back to you C.O.D. for the service and shipping charges, plus the cost of parts not covered by the warranty.

Attach the envelope containing one copy of this letter directly to the unit before packaging, so that we do not overlook this important information. Send the second copy of the letter by separate mail to Heath Company, Attention: Service Department, Benton Harbor, Michigan.

Check the equipment to see that all parts and screws are in place. (Do not include wooden cabinets when shipping receivers, tuners, amplifiers, or TV sets, as these are easily damaged in shipment.) Then, wrap the equipment in heavy paper. Place the equipment in a strong carton, and put at least **THREE INCHES** of resilient packing material (shredded paper, excelsior, etc.) on all sides, between the equipment and the carton. Seal the carton with gummed paper tape, and tie it with a strong cord. Ship it by prepaid express, United Parcel Service, or insured parcel post to:

Heath Company  
Service Department  
Benton Harbor, Michigan 49022

## SPECIFICATIONS

### RF OUTPUT SIGNAL

|                              |                                                                                                                   |
|------------------------------|-------------------------------------------------------------------------------------------------------------------|
| Frequency Range. . . . .     | 100 kc to 110 mc in six bands (bands A through F).<br>100 mc to 220 mc (additional band of calibrated harmonics). |
| Frequency Accuracy. . . . .  | ±2%.                                                                                                              |
| Output Impedance. . . . .    | 50 ohms.                                                                                                          |
| Internal Modulation. . . . . | 400 cps (30% modulation).                                                                                         |
| External Modulation. . . . . | 3 volt signal input for 30% modulation.                                                                           |

### AF OUTPUT SIGNAL

|                         |                          |
|-------------------------|--------------------------|
| Frequency. . . . .      | 400 cps.                 |
| Output Voltage. . . . . | 10 volts (open circuit). |

### GENERAL

|                               |                                                                                                                                                                         |
|-------------------------------|-------------------------------------------------------------------------------------------------------------------------------------------------------------------------|
| Front Panel Controls. . . . . | Variable Frequency control.<br>Band switch.<br>Fine Attenuator control.<br>Coarse Attenuator switch.<br>External Modulation or AF Output control.<br>Modulation switch. |
| Tube Complement. . . . .      | 12AT7 RF oscillator.<br>6AN8 amplifier and modulator.                                                                                                                   |
| Power Requirements. . . . .   | 105 to 125 volts AC, 50/60 cps, 15 watts.                                                                                                                               |
| Cabinet Dimensions. . . . .   | 6-1/2" wide x 9-1/2" high x 5" deep.                                                                                                                                    |
| Net Weight. . . . .           | 4-1/2 lbs.                                                                                                                                                              |

The Heath Company reserves the right to discontinue instruments and to change specifications at any time without incurring any obligation to

incorporate new features in instruments previously sold.

## CIRCUIT DESCRIPTION

Refer to the Block Diagram and Schematic (fold-out from Page 33) to follow the circuit and identify the circuit components while reading this description.

The Circuit Description of the RF Signal Generator is outlined in four sections: RF Oscillator, AF Oscillator, Amplifier And Modulator, and Power Supply.

### RF OSCILLATOR

A Hartley oscillator, consisting of tube V1B and its associated circuitry, is used to generate the RF signal for bands A, B, C, D, and E. The correct coil for each band of frequencies is selected by Band switch S2.

Section BF of Band switch S2, supplies B+ voltage to the plate of tube V1B when the switch is in positions A through E. The desired oscillator coil is connected through capacitor C7 to the grid of tube V1B by section AF of Band switch S2. The tap of each coil is connected to the cathode of tube V1B by section BR of Band switch S2. Section AR of Band switch S2 shorts out all oscillator coils except the one being used.

Capacitor C9, which is one section of the tuning capacitor, is connected across the desired oscillator coil and completes the tuned circuit of the RF oscillator. Trimmer capacitor C6, which is connected to the grid of tube V1B, adjusts the oscillator frequency on bands A through E.

Resistor R3 and capacitor C7 supply bias voltage to the grid of tube V1B. The RF signal is coupled through capacitor C8 to the grid of tube V2B.

Tube V1A is the RF oscillator stage for band F only. Coil F is permanently connected to the grid of tube V1A through resistor R1 and capacitor C3. This helps reduce variations in wiring capacitance that would occur if this coil were switched like the other coils. These variations would cause the dial calibration to be inaccurate on band F.

Capacitor C1, which is one section of the tuning capacitor, is connected across coil F to complete the tuned circuit for band F. Section BF of Band switch S2 supplies B+ voltage to the plate of tube V1A when the switch is in position F. Capacitor C3 and resistor R1 supply bias voltage to the grid of tube V1A. The RF signal is coupled from the cathode of tube V1A through capacitor C4 to the grid of tube V2B.

### AF OSCILLATOR

Tube V2A, which is connected as an AF oscillator, is tuned by transformer T2 and capacitor C15 to oscillate at a frequency of about 400 cps. The 400 cps audio signal is coupled from the plate of tube V2A through capacitor C17 and resistors R7 and R8 to the grid of tube V2B. This audio signal is also applied across control R4 and through capacitor C11 to the AF Output Connector.

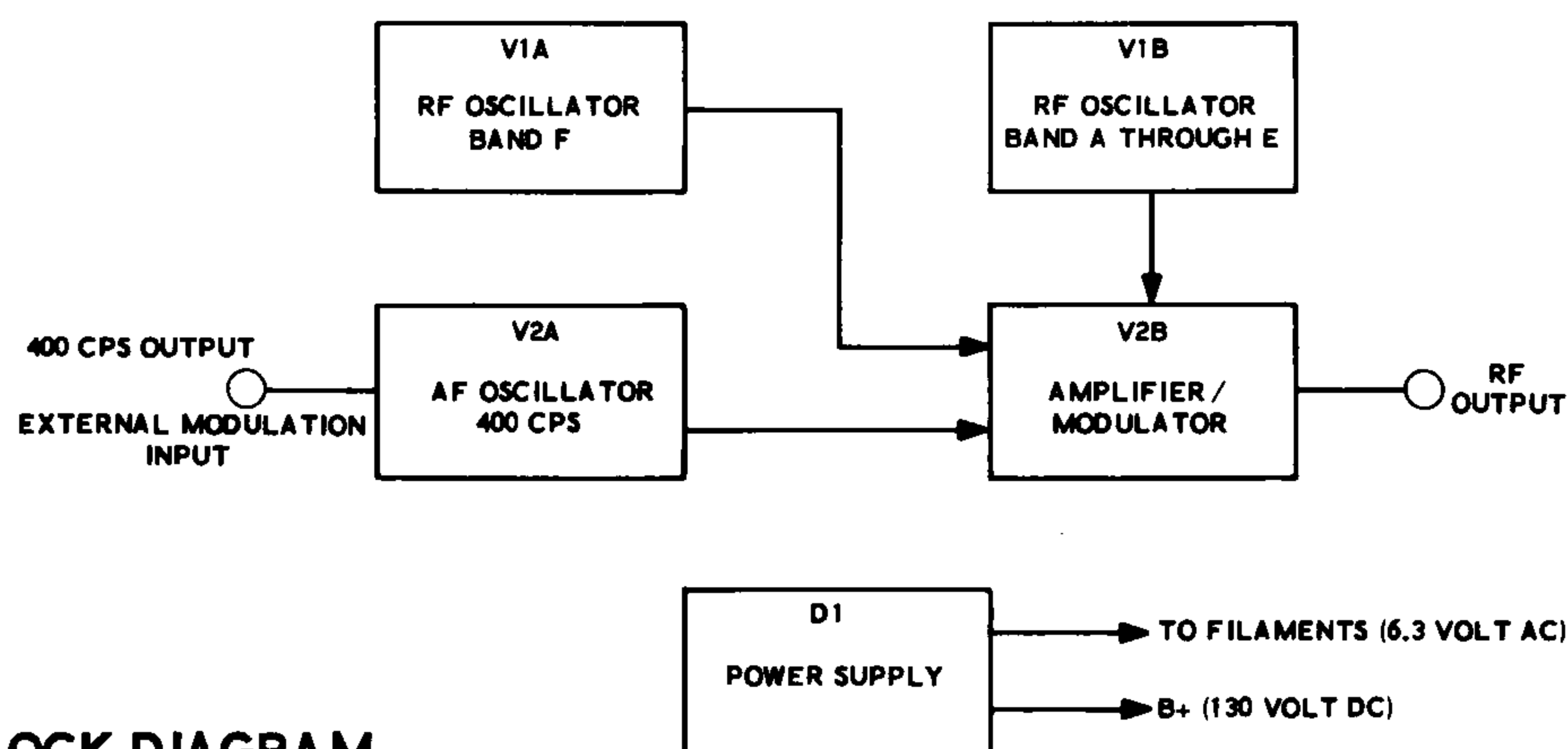

**BLOCK DIAGRAM**

When switch S3 is in the External Modulation position, tube V2A is used to amplify the external modulation signal that is connected to the External Modulation In connector. This signal is coupled through capacitor C11 to control R4, and then to the grid of tube V2A. The signal is then amplified by tube V2A and coupled through capacitor C17 and resistors R7 and R8 to the grid of tube V2B.

### AMPLIFIER AND MODULATOR

The RF and AF signals are coupled to the grid of tube V2B. Resistors R7 and R9 keep the AF signal from overdriving the grid of tube V2B and also determine the modulation level. From the plate of tube V2B, the modulated

RF signal is coupled through capacitor C20, Fine Attenuator control R12, Coarse Attenuator switch S4, and capacitor C22 to the RF Output connector.

### POWER SUPPLY

B+ voltage is supplied to all stages of the Generator by a half-wave rectifier circuit consisting of diode D1. Resistor R17 with capacitors C25A and C25B provide filtering of the B+ voltage.

Filament voltage is supplied to the filaments of all tubes and the #47 lamp by a 6.3 volt AC winding on power transformer T1.

## REPLACEMENT PARTS PRICE LIST

To order parts, use the Parts Order Form furnished with this kit. If a Parts Order Form is not available, refer to Replacement Parts in the Kit Builders Guide.

| <u>PART No.</u>     | <u>PRICE Each</u> | <u>DESCRIPTION</u> | <u>PART No.</u>                       | <u>PRICE Each</u> | <u>DESCRIPTION</u>                      |
|---------------------|-------------------|--------------------|---------------------------------------|-------------------|-----------------------------------------|
| <b>RESISTORS</b>    |                   |                    | <b>Tubular</b>                        |                   |                                         |
| <b>1/2 Watt</b>     |                   |                    | 23-39                                 | .20               | .0047 $\mu$ fd                          |
| 1-1                 | .10               | 47 $\Omega$        | 23-50                                 | .15               | .022 $\mu$ fd                           |
| 1-48                | .10               | 390 $\Omega$       | 23-59                                 | .20               | .05 $\mu$ fd                            |
| 1-7                 | .10               | 680 $\Omega$       | 23-28                                 | .20               | .1 $\mu$ fd                             |
| 1-16                | .10               | 4700 $\Omega$      | <b>Other</b>                          |                   |                                         |
| 1-24                | .10               | 33 K $\Omega$      | 28-1                                  | .10               | 2.2 $\mu$ mf molded phenolic            |
| 1-47                | .10               | 56 K $\Omega$      | 21-29                                 | .15               | 4.7 $\mu$ mf N750 tubular ceramic       |
| 1-26                | .10               | 100 K $\Omega$     | 20-99                                 | .15               | 22 $\mu$ mf mica                        |
| <b>1 Watt</b>       |                   |                    | 20-101                                | .15               | 47 $\mu$ mf mica                        |
| 1-23-1              | .10               | 2200 $\Omega$      | 25-7                                  | 1.00              | 20-20 $\mu$ fd electrolytic             |
| <b>CAPACITORS</b>   |                   |                    | 31-8                                  | .30               | 1-10 $\mu$ mf trimmer                   |
| <b>Disc Ceramic</b> |                   |                    | 26-57                                 | 2.70              | Dual tuning                             |
| 21-32               | .10               | 47 $\mu$ mf        | <b>CONTROLS-TRANSFORMERS-SWITCHES</b> |                   |                                         |
| 21-14               | .10               | .001 $\mu$ fd      | 10-27                                 | .50               | 3000 $\Omega$ control                   |
| 21-27               | .10               | .005 $\mu$ fd      | 19-11                                 | .75               | 100 K $\Omega$ control with SPST switch |
| 21-16               | .10               | .01 $\mu$ fd       | 51-44                                 | 1.30              | Oscillator transformer                  |
| 21-31               | .10               | .02 $\mu$ fd       | 54-92                                 | 2.80              | Power transformer                       |

| PART No.                                        | PRICE Each | DESCRIPTION                   |
|-------------------------------------------------|------------|-------------------------------|
| <b>Controls-Transformers-Switches (cont'd.)</b> |            |                               |
| 63-70                                           | .95        | 3-position rotary switch      |
| 63-211                                          | .75        | 2-position rotary switch      |
| 163-2                                           | 5.00       | Band switch and coil assembly |

**RECTIFIER-TUBES-LAMP**

|        |      |               |
|--------|------|---------------|
| 57-27  | .60  | Silicon diode |
| 411-24 | 1.45 | 12AT7 tube    |
| 411-68 | 1.90 | 6AN8 tube     |
| 412-1  | .15  | #47 lamp      |

**TERMINAL STRIPS**

|        |     |                      |
|--------|-----|----------------------|
| 431-10 | .10 | 3-lug terminal strip |
| 431-40 | .10 | 4-lug terminal strip |
| 431-11 | .10 | 5-lug terminal strip |

**CONNECTORS-SOCKETS**

|        |     |                   |
|--------|-----|-------------------|
| 432-1  | .35 | Cable connector   |
| 432-3  | .25 | Chassis connector |
| 434-77 | .15 | 9-pin tube socket |
| 434-87 | .35 | Pilot lamp socket |

**HARDWARE**

|        |     |                       |
|--------|-----|-----------------------|
| 250-49 | .05 | 3-48 x 1/4" screw     |
| 250-7  | .05 | 6-32 x 3/16" screw    |
| 250-56 | .05 | 6-32 x 1/4" screw     |
| 250-89 | .05 | 6-32 x 3/8" screw     |
| 250-83 | .05 | #10 sheet metal screw |
| 250-16 | .05 | 8-32 setscrew         |
| 252-1  | .05 | 3-48 nut              |
| 252-3  | .05 | 6-32 nut              |
| 252-37 | .05 | 9/32-32 x 3/8" nut    |
| 252-7  | .05 | Control nut           |
| 252-22 | .05 | Speednut              |
| 254-1  | .05 | #6 lockwasher         |
| 254-4  | .05 | Control lockwasher    |
| 253-10 | .05 | Control flat washer   |
| 259-1  | .05 | #6 solder lug         |
| 259-10 | .05 | Control solder lug    |

| PART No.                   | PRICE Each | DESCRIPTION            |
|----------------------------|------------|------------------------|
| <b>WIRE-CABLE-SLEEVING</b> |            |                        |
| 89-1                       | .35        | Line cord              |
| 340-2                      | .05/ft     | Bare wire              |
| 344-59                     | .05/ft     | Hookup wire            |
| 343-2                      | .10/ft     | Coaxial cable RG-58A/U |
| 347-3                      | .10/ft     | 2-lead shielded cable  |
| 346-1                      | .05/ft     | Sleeving               |

**METAL PARTS**

|           |      |             |
|-----------|------|-------------|
| 90-253    | 4.85 | Cabinet     |
| 200-442   | 1.50 | Chassis     |
| 203-180-2 | 1.25 | Front panel |

**MISCELLANEOUS**

|         |      |                                           |
|---------|------|-------------------------------------------|
| 40-193  | .30  | Band F oscillator coil                    |
| 73-1    | .10  | Rubber grommet                            |
| 75-71   | .10  | Line cord strain relief                   |
| 100-10  | .20  | Dial pointer assembly                     |
| 205-254 | .10  | Alignment tool blade                      |
| 207-4   | .10  | Cable clamp                               |
| 211-15  | .20  | Handle                                    |
| 260-1   | .15  | Alligator clip                            |
| 413-4   | .30  | Pilot lamp jewel                          |
| 462-187 | .30  | Pointer knob                              |
| 462-140 | .30  | Large knob                                |
| 490-1   | .10  | Coil alignment tool                       |
| 490-5   | .10  | Plastic nut starter                       |
| 331-6   | .15  | Solder                                    |
|         | 2.00 | Manual (See front cover for part number.) |

The above prices apply only on purchases from the Heath Company where shipment is to a U.S.A. destination. Add 10% (minimum 25 cents) to the price when ordering from an authorized Service Center or Heathkit Electronic Center to cover local sales tax, postage and handling. Outside the U.S.A. parts and service are available from your local Heathkit source and will reflect additional transportation, taxes, duties and rates of exchange.

**\*\*BAND SWITCH S2**

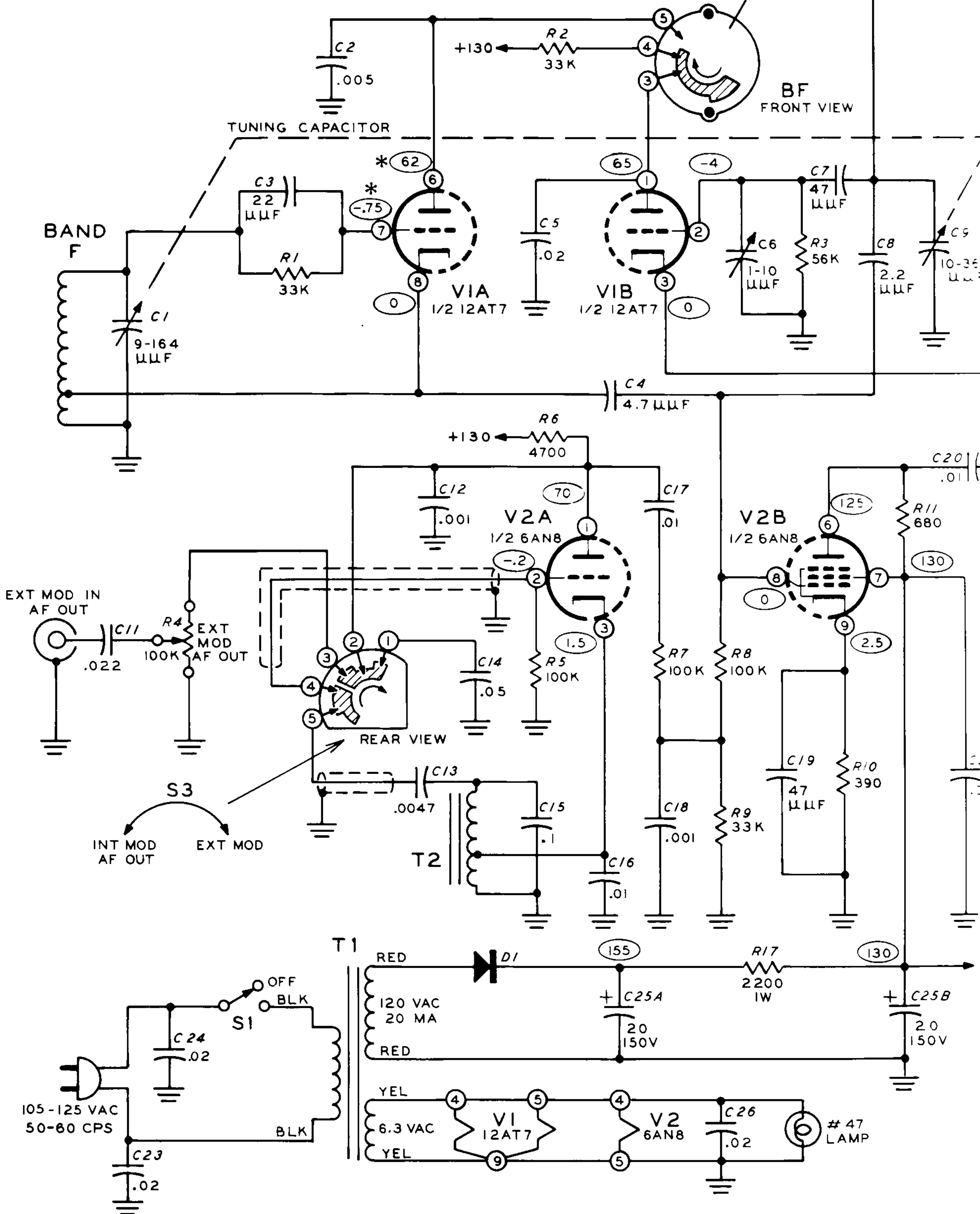
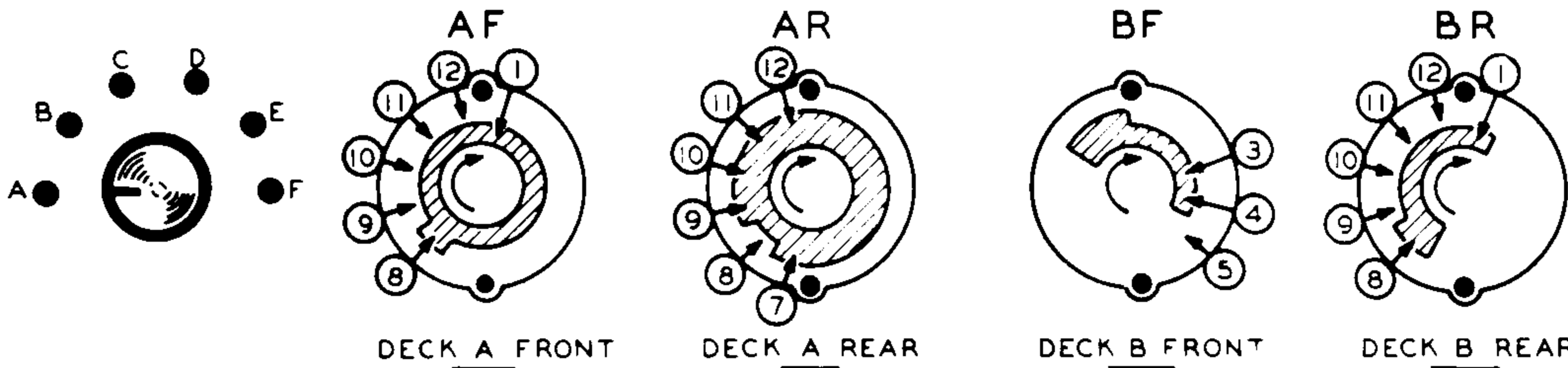

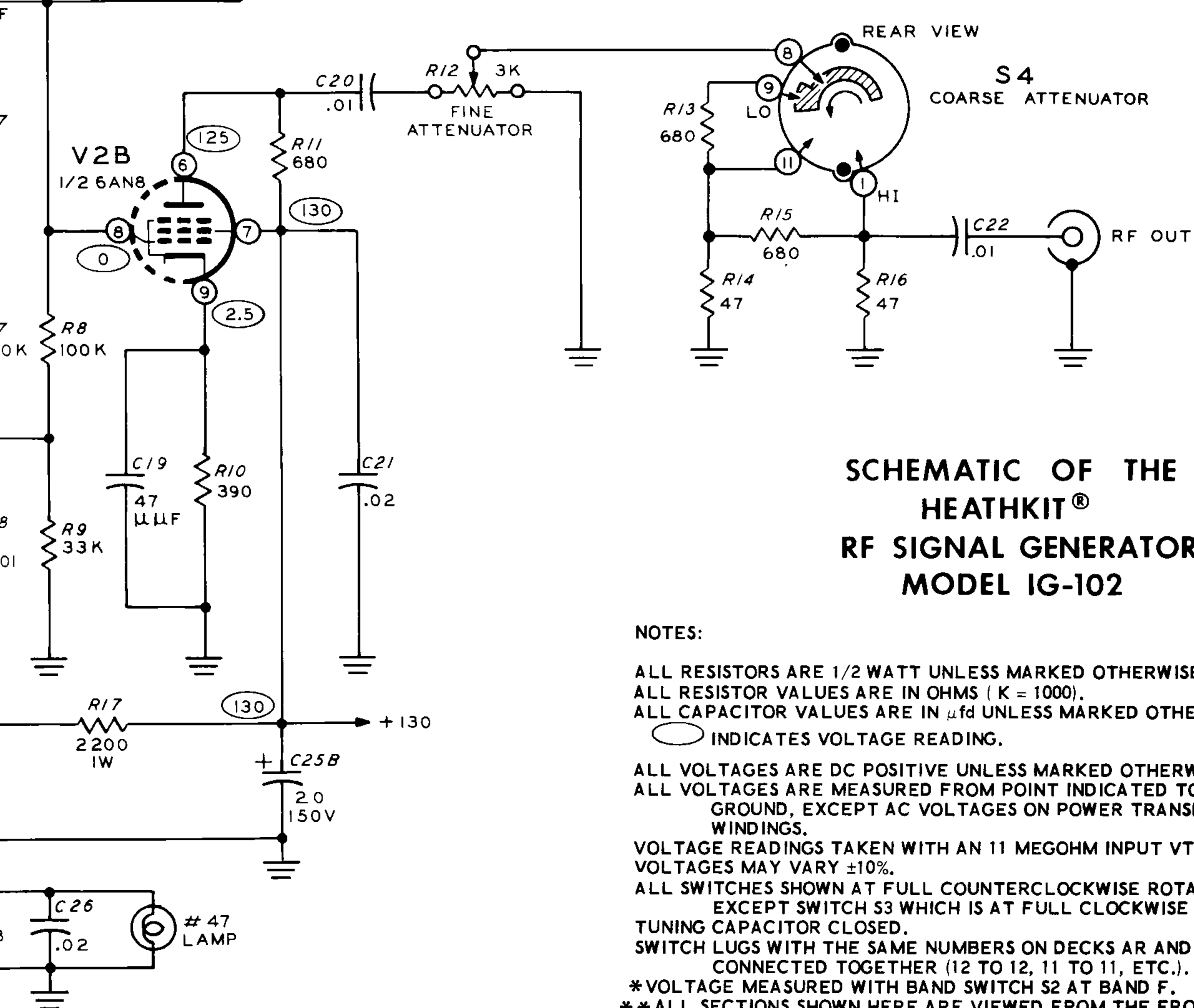
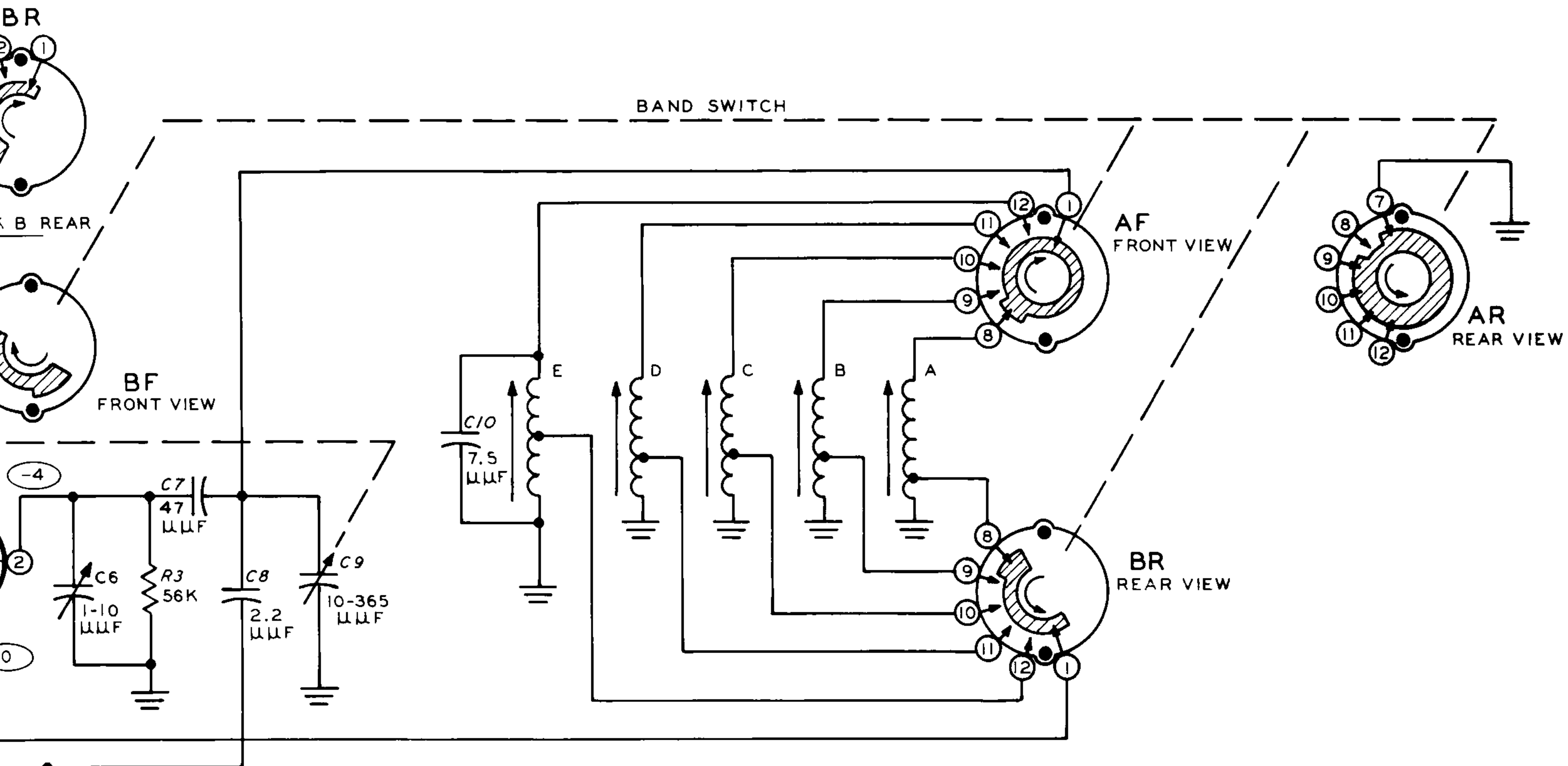

## SCHEMATIC OF THE HEATHKIT® RF SIGNAL GENERATOR MODEL IG-102

### NOTES:

ALL RESISTORS ARE 1/2 WATT UNLESS MARKED OTHERWISE.  
ALL RESISTOR VALUES ARE IN OHMS ( K = 1000 ).  
ALL CAPACITOR VALUES ARE IN  $\mu\text{fd}$  UNLESS MARKED OTHERWISE.

○ INDICATES VOLTAGE READING.

ALL VOLTAGES ARE DC POSITIVE UNLESS MARKED OTHERWISE.  
ALL VOLTAGES ARE MEASURED FROM POINT INDICATED TO CHASSIS  
GROUND, EXCEPT AC VOLTAGES ON POWER TRANSFORMER  
WINDINGS.

VOLTAGE READINGS TAKEN WITH AN 11 MEGOHM INPUT VTVM.  
VOLTAGES MAY VARY  $\pm 10\%$ .

ALL SWITCHES SHOWN AT FULL COUNTERCLOCKWISE ROTATION,  
EXCEPT SWITCH S3 WHICH IS AT FULL CLOCKWISE ROTATION.  
TUNING CAPACITOR CLOSED.

SWITCH LUGS WITH THE SAME NUMBERS ON DECKS AR AND AF ARE  
CONNECTED TOGETHER (12 TO 12, 11 TO 11, ETC.).

\* VOLTAGE MEASURED WITH BAND SWITCH S2 AT BAND F.  
\*\* ALL SECTIONS SHOWN HERE ARE VIEWED FROM THE FRONT  
PANEL: SWITCH SHOWN IN BAND A POSITION.

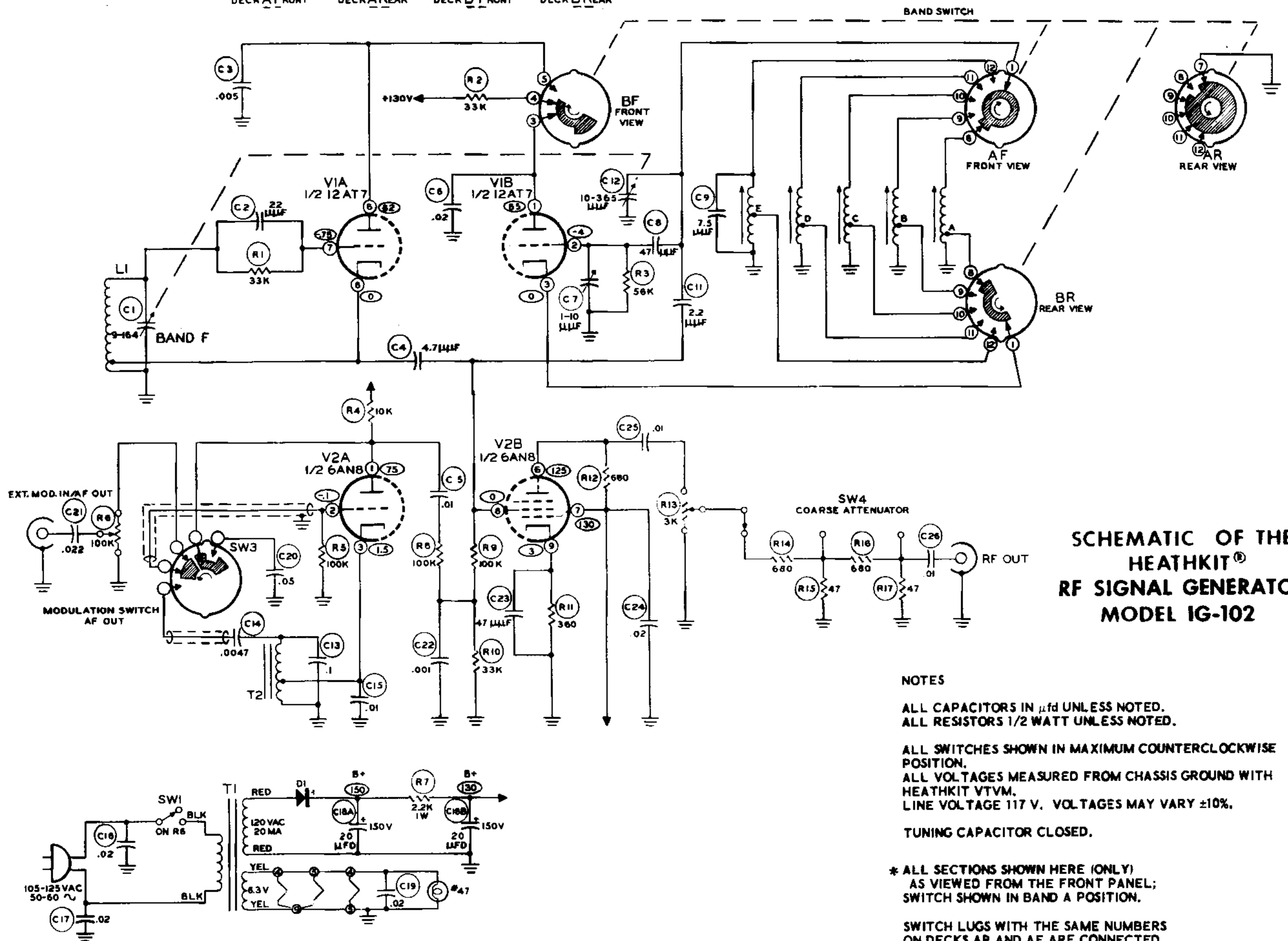
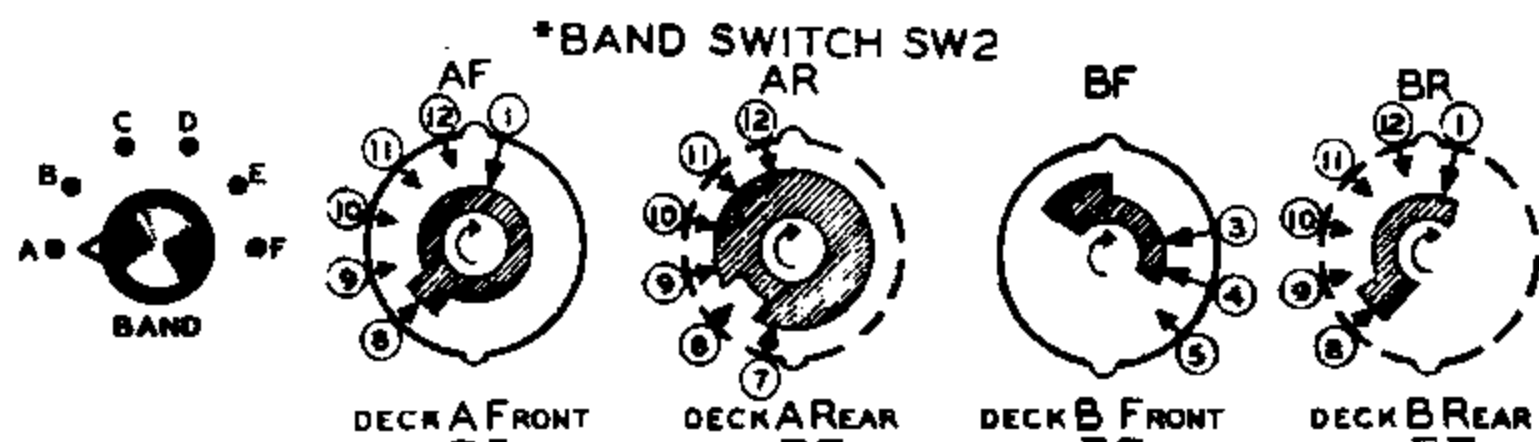

## SCHEMATIC OF THE HEATHKIT® RF SIGNAL GENERATOR MODEL IG-102

### NOTES

ALL CAPACITORS IN  $\mu\text{fd}$  UNLESS NOTED.  
ALL RESISTORS 1/2 WATT UNLESS NOTED.

ALL SWITCHES SHOWN IN MAXIMUM COUNTERCLOCKWISE POSITION.

ALL VOLTAGES MEASURED FROM CHASSIS GROUND WITH HEATHKIT VTVM.

LINE VOLTAGE 117 V. VOLTAGES MAY VARY  $\pm 10\%$ .

TUNING CAPACITOR CLOSED.

\* ALL SECTIONS SHOWN HERE (ONLY)  
AS VIEWED FROM THE FRONT PANEL;  
SWITCH SHOWN IN BAND A POSITION.

SWITCH LUGS WITH THE SAME NUMBERS  
ON DECKS AR AND AF ARE CONNECTED  
TOGETHER (12 TO 12, 11 TO 11, ETC.)





# HEATH COMPANY

Phone 616-983-3961 • TWX-616-983-3897 • Benton Harbor, Michigan 49022

Dear Customer:

We have included a power transformer that enables you to wire your kit to operate from either a 120 volt or a 240 volt AC power source (50/60 cps). This transformer has two additional leads in its primary windings that are not mentioned in your Manual. The following steps will tell you how to combine these leads to produce the correct voltages in your kit.

**NOTE:** In the U.S.A. your power source (line voltage) is usually 120 volts AC, while in other countries it is more common to have a power source of 240 volts AC. Perform only one of the following two sets of instructions. **USE ONLY THE SET OF INSTRUCTIONS THAT AGREE WITH THE POWER SOURCE IN YOUR AREA!**

## Transformer Prewiring for use with a 120 VOLT AC Power Source:

- ( ) Locate the power transformer. Its part number starts with 54- . . . .
- ( ) Twist the black lead and the black-green lead together. Place insulating tape around this pair at 1-1/2" intervals.
- ( ) Twist the black-red and the black-yellow leads together. Place insulating tape around this pair also at 1-1/2" intervals.

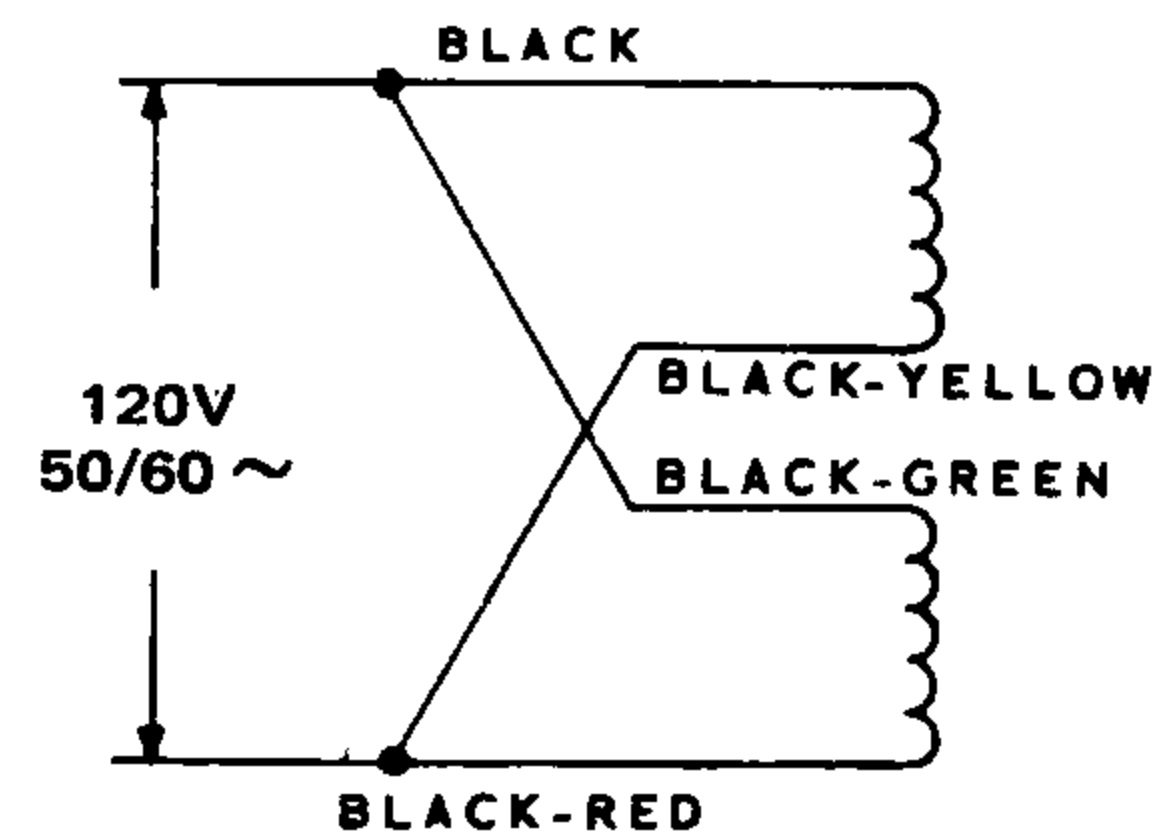
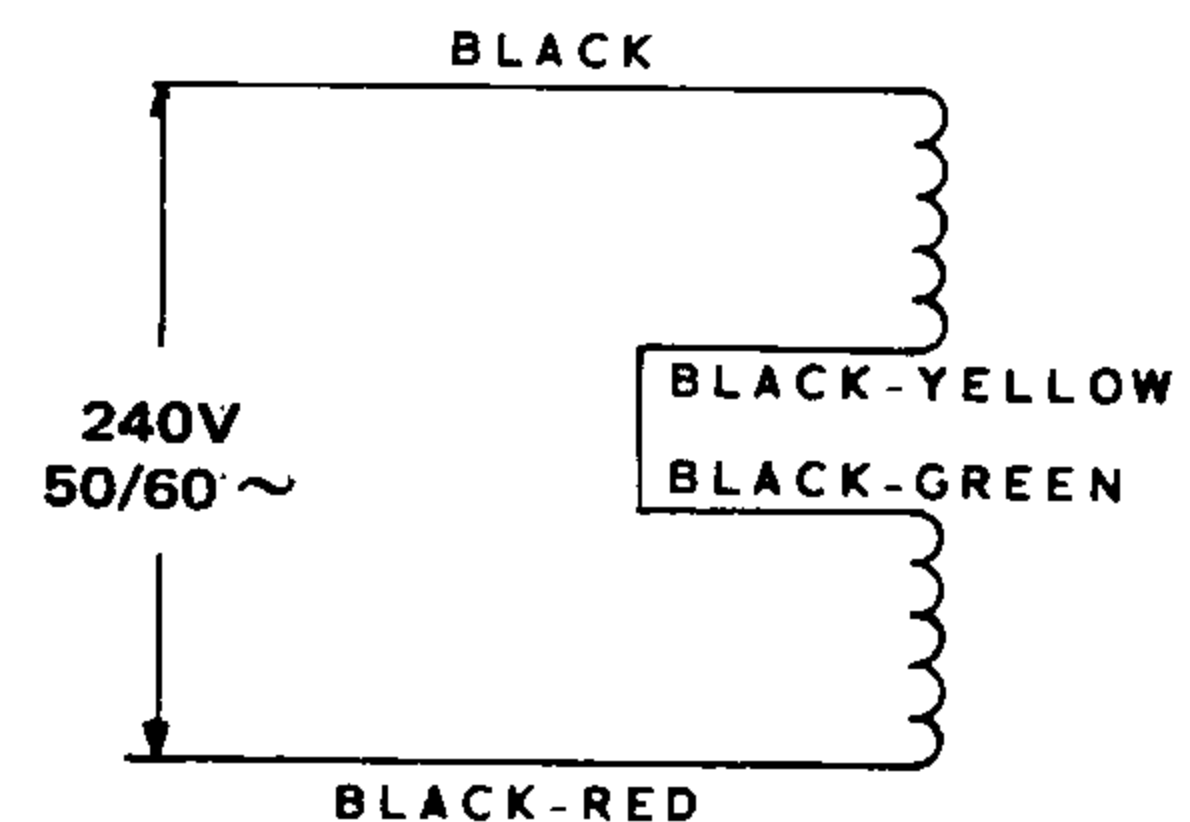

**Figure 1**

From this point on, please consider each of these taped pairs as one black lead. When, for example, a step in the Manual directs you to prepare, connect or solder a black transformer lead, use both of the leads in the taped pair.

## Transformer Prewiring for use with a 240 VOLT AC Power Source:

- ( ) Locate the power transformer. Its part number starts with 54- . . . .
- ( ) Cut the black-yellow and the black-green leads to a 1-1/2" length, measured from where the leads emerge from the transformer.
- ( ) Remove 3/8" of insulation from the end of each of these leads.



**Figure 2**

- ( ) Twist the bared ends of the two leads together and solder the connection. Place insulating tape over the joint.

When your Manual directs you to work with the two black transformer leads, please consider the black-red lead as "the other" black lead.

E Transformer  
597-497

# **HEATH COMPANY**

***THE WORLD'S FINEST ELECTRONIC EQUIPMENT IN KIT FORM***

LITHO IN U.S.A.