

ASSEMBLY AND OPERATION OF THE HEATHKIT R. F. PROBE MODEL 309-C

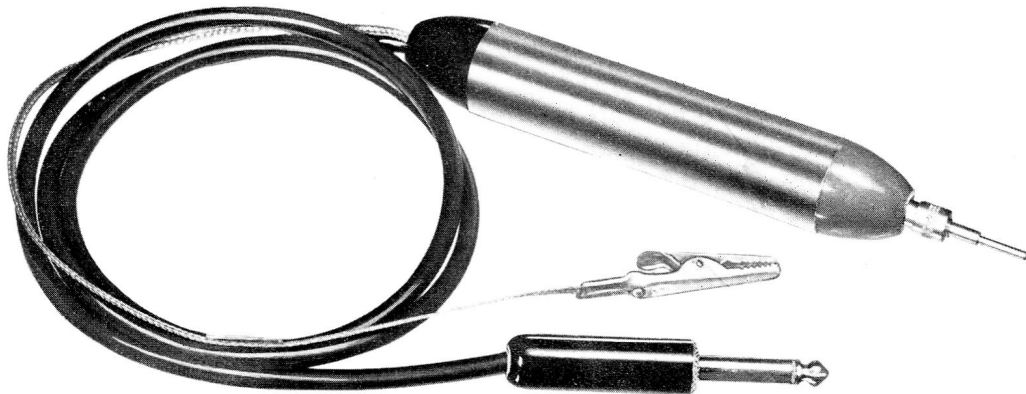

The #309-C crystal probe extends the AC range of any 11 megohm input vacuum tube voltmeter to over 100 megacycles. A crystal diode employed as a rectifier is capable of linear response over a very wide range of frequencies. Response of the #309-C probe is substantially flat from 1000 cycles to over 100 megacycles. D. C. isolation is provided by the .005 μ fd condenser. A ceramic capacitor of this type has low impedance to RF and is ideal for use in this application. The 4.7 megohm resistor acts as a combination isolation filter and multiplier. Voltage at the cable end of the resistor is negative DC and the VTVM selector should be set accordingly.

A well shielded probe with the detecting elements contained in the housing is necessary for satisfactory readings at high frequencies. The Heathkit #309-C RF Probe meets these requirements. Input leads are extremely short in order to eliminate extraneous signal pickup which can give false readings. The metal probe housing is grounded to prevent hand capacity effects from causing deflection of the meter needle. Etched circuit wiring cuts down circuit capacity, improving high frequency response.

The input capacitor is rated at 500 volts DC and the probe should not be applied to circuits where DC voltages higher than this are found. AC or RF voltages in excess of 30 volts should not be measured, as damage to the crystal may result. As this probe is designed primarily for RF, signals below 1000 cycles will read low and the rectifier in the VTVM should be employed by turning the selector switch to AC. The capacitive effect of the regular AC leads will be negligible at frequencies below 1000 cycles.

Accuracy of the probe is maintained within approximately $\pm 10\%$ and this accuracy is adequate for RF work. The readings obtained are RMS and should be multiplied by 1.414 to convert to peak readings.

PROBE CONSTRUCTION

ROSIN CORE SOLDER HAS BEEN SUPPLIED WITH THIS KIT. THIS TYPE OF SOLDER MUST BE USED FOR ALL SOLDERING IN THIS KIT. ALL GUARANTEES ARE VOIDED AND WE WILL NOT REPAIR OR SERVICE EQUIPMENT IN WHICH ACID CORE SOLDER OR PASTE FLUXES HAVE BEEN USED. IF ADDITIONAL SOLDER IS NEEDED, BE SURE TO PURCHASE ROSIN CORE (60:40 or 50:50 TIN-LEAD CONTENT) RADIO TYPE SOLDER.

The pictorial clearly shows assembly detail of the probe and etched circuit board. Begin construction by mounting the components on the circuit board in the numbered sequence shown on the pictorial. All parts will mount on the unmarked side of the board, with their leads coming out on the etched side. Generally, it is best to mount all components before soldering, bending the leads over slightly to lock the parts in place. After all parts are secured, the board should be turned over and each lead soldered at the point where it comes through with a 25 or 50 watt soldering iron. After soldering, all leads should be clipped off.

For best soldering results, a 25 to 50 watt iron is recommended. The tip should be clean and well tinned in order to obtain a quick, clean solder joint. Hold the tip of the iron at the junction of the component lead and the etched board conductor, and apply good quality rosin core solder at the same point until a good connection is obtained between the two parts. When all parts are clean, the connection can be made very quickly, preventing heat damage to resistors and condensers. In order to protect crystal diodes, a clamp, needle nosed pliers or some other type of heat barrier should be clamped on the diode lead between the diode and connection, on the opposite side of the board from the connection.

Place the length of flat braid and the shielded cable through the black probe end. Remove 1" of black outer insulation. Push the braid back until a bulge develops near the end of the outer insulation. Bend the end over, poke a hole in the shield braid with a sharp tool and pull the center conductor through as shown. Bend the flat braid and shield braid back together over the flat portion of the probe end and solder together. Make sure that the two braids are as flat as possible or it will be difficult to install the probe body.

Fit the insulator strip tight against the probe end and solder the shield lead coming from the circuit board to the two braids near the center conductor. Cut the center conductor to length sufficient to reach the hole marked "lead." Strip away 1/8" of insulation and solder the center conductor at this point. Cut off all excess wire at this end.

Prepare the probe body by inserting the large sleeve. Slip the entire assembly over the circuit board and rear probe end and secure with two self-tapping screws. Install the phone tip in the red probe end and remove the collar. Insert this end into the probe body, making sure that the lead from the circuit board tip appears through the hole at the side of the tip. Secure with the remaining self-tapping screws. Wrap the wire around the tip in the space provided and reinstall the collar. Solder an alligator clip to the flat braid.

At the opposite end of the cable, strip away 1" of black outer insulation. Prepare as before. Slip the phone plug shell over the cable and solder the center conductor to the center lug of the plug. Solder the braid to the outside lug. Make sure that no shorts exist and screw the shell back on to the plug. This completes the assembly of the RF probe.

The RF probe and VTVM may be used as a signal tracer and gain analyzer, as well as an RF voltage measuring device. If a receiver is not functioning properly, the probe can be connected to the plates of the second detector and the amount of RF energy noted. If none, the probe should be moved back to the plate of the last IF stage and meter observed again. If still no indication, the probe should be moved to the grid of this stage, etc. The point at which RF energy appears isolates the trouble to the point in the circuit immediately following. Operation of local oscillator can be checked by connecting the probe to the grid or cathode of the oscillator tube. It must be remembered that probe sensitivity is limited by the sensitivity of the VTVM, so it is unlikely that satisfactory indication will be obtained in the RF and mixer stages of a receiver.

PREPARING SHIELDED CABLE

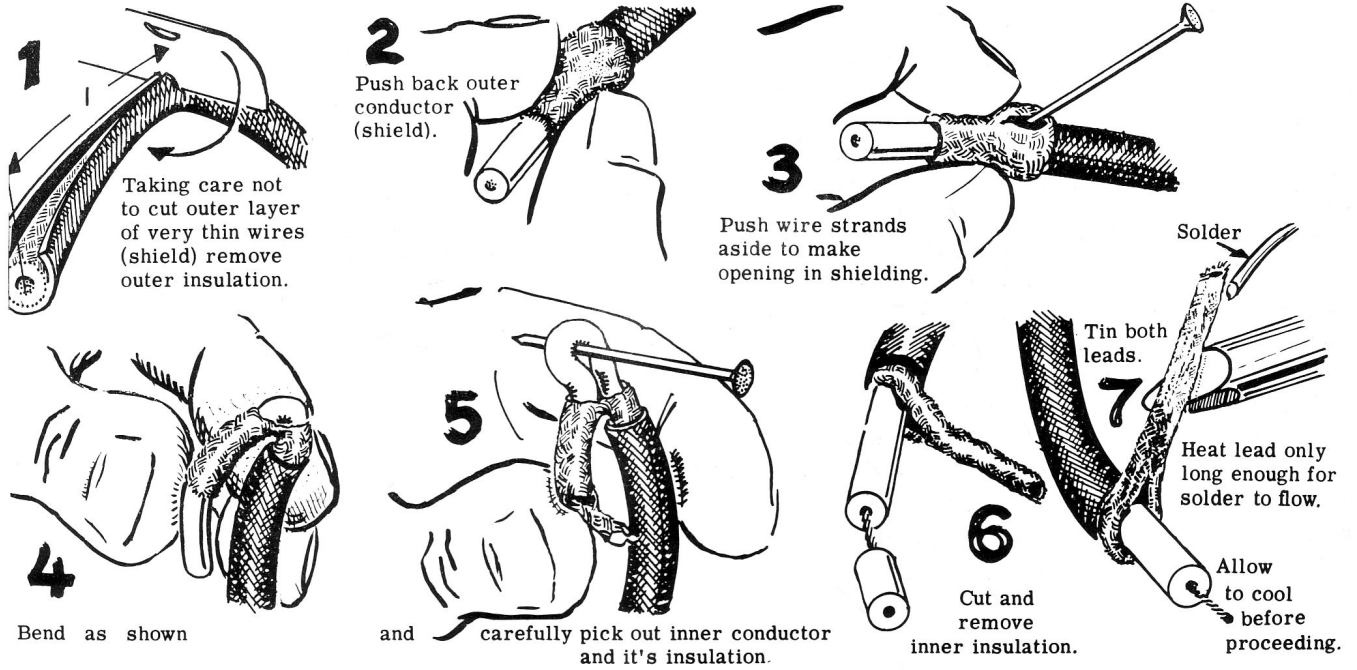

PHONE PLUG INSTALLATION

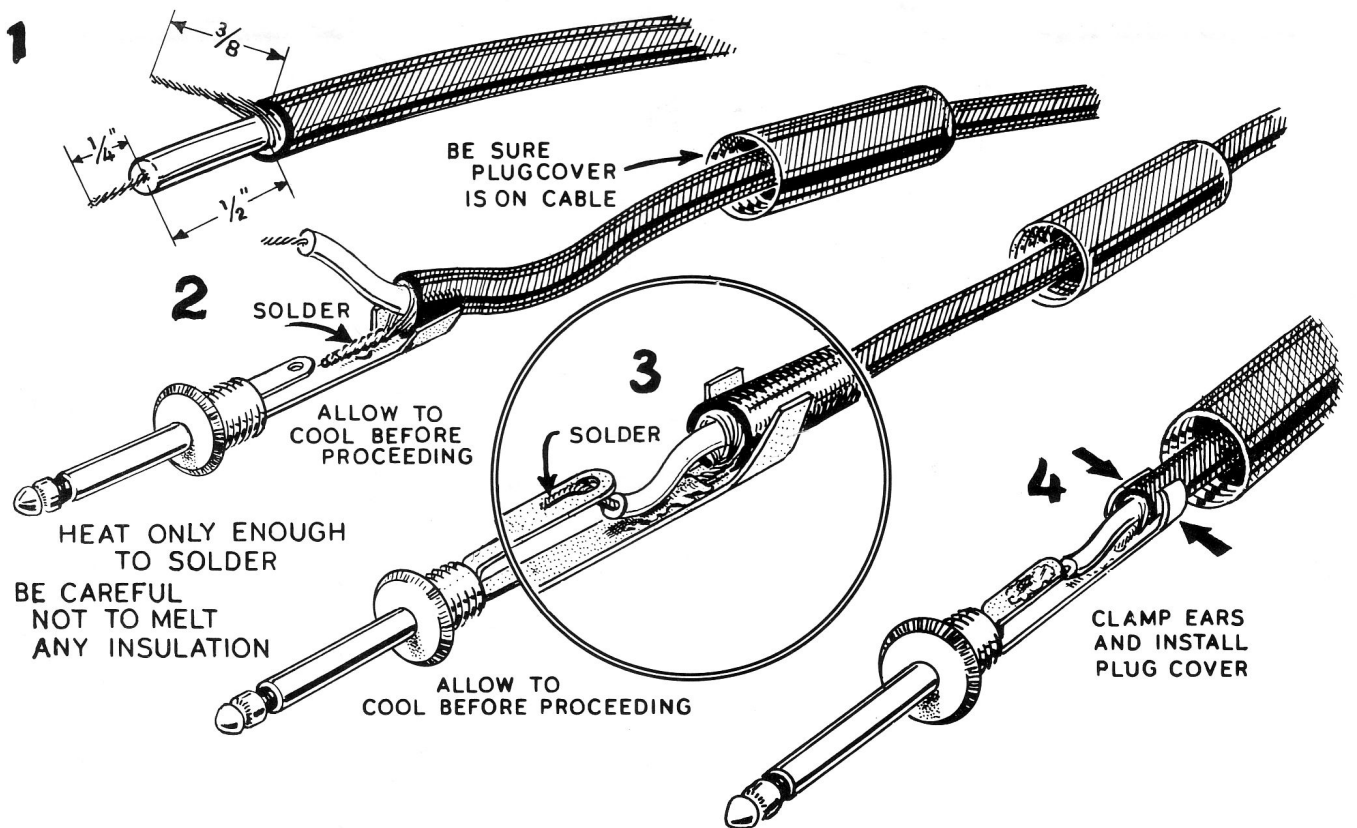

To check RF or IF amplifier gain, the same procedure should be observed. Write down the readings obtained and divide the output voltage by the input voltage. The answer obtained will be the gain of the stage or stages. The 30 volt AC maximum rating of the probe should be remembered when this type of measurement is made. The probe can be connected to DC high voltage points up to 500 volts safely, as long as the superimposed RF voltage does not exceed the 30 volt limit.

WARRANTY

Heath Company warrants that all Heathkit parts shall be free of all defects in materials and workmanship under normal use and service, and in fulfillment of such warranty Heath Company will, for a period of three months from the date of shipment, replace any part upon verification that it is defective.

The foregoing warranty shall apply only to the original buyer, and is and shall be in lieu of all other warranties, whether express or implied and of all other obligations or liabilities on the part of Heath Company and in no event shall Heath Company be liable for any anticipated profits, consequential damages, loss of time or other losses incurred by the buyer in connection with the purchase, assembly or operation of Heathkits or components thereof. No replacement shall be made of parts damaged by the buyer in the course of handling or assembling Heathkit equipment.

The foregoing warranty is completely void if corrosive solder or fluxes have been used in wiring the equipment. Heath Company will not replace or repair any equipment in which corrosive solder or fluxes have been used.

This warranty applies only to Heath equipment sold and shipped within the continental United States including APO and FPO shipments. Warranty replacements for Heathkit equipment outside the United States is on a f.o.b. factory basis. Contact the Heathkit authorized distributor in your country or write: Heath Company, International Division, Benton Harbor, Michigan, U.S.A.

HEATH COMPANY

All prices are subject to change without notice. The Heath Company reserves the right to discontinue instruments and to change specifications at any time without incurring any obligation to incorporate new features in instruments previously sold.

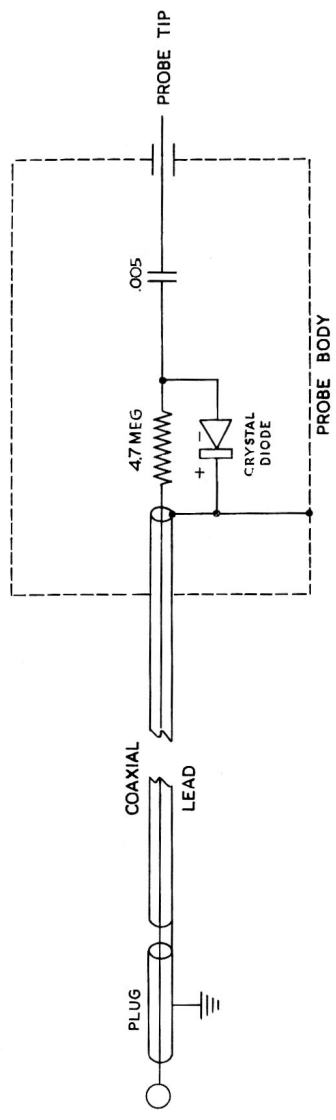
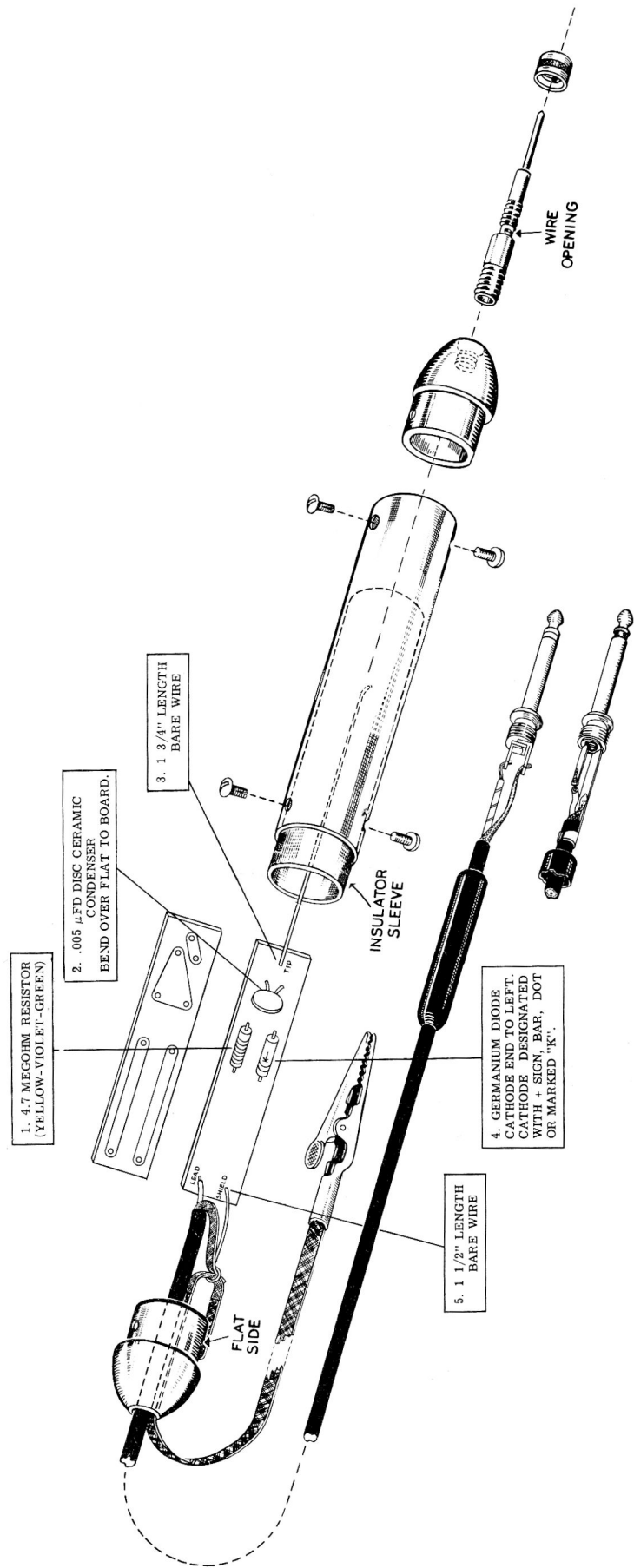

RF PROBE 309-C

PARTS LIST

PART No.	PARTS Per Kit	DESCRIPTION
1-39	1	4.7 megohm 5% resistor
21-27	1	.005 μ fd disc ceramic capacitor
56-4	1	Crystal diode
70-4	1	Acetate insulator sleeve
85-2	1	Etched circuit board
250-1	4	Self-tapping screw
260-1	1	Alligator clip
340-2	1	Length bare wire
343-2	1	Length shielded test lead
345-1	1	Length flat braid
390-13	1	Label
438-3	1	Phone plug
459-M2	1	Red probe tip end (tapped)
459-M3	1	Black probe tip end (not tapped)
476-M8	1	Aluminum probe body
477-3	1	Solderless phone tip
331-6		Solder
595-96	1	Instruction sheet

