



INSTRUCTION MANUAL



MODEL **R-4C** RECEIVER



LIMITED WARRANTY

R. L. DRAKE COMPANY warrants to the original purchaser that this product shall be free from defects in material (except tubes and RF output transistors) or workmanship for ninety (90) days from the date of original purchase.

During the warranty period the R. L. DRAKE COMPANY or an authorized Drake service facility will provide free of charge both parts (except tubes and RF output transistors) and labor necessary to correct defects in material or workmanship.

To obtain such warranty service, the original purchaser must:

- (1) Complete and send in the Warranty Registration Card.*
- (2) Notify R. L. DRAKE COMPANY or its nearest authorized service facility, as soon as possible after discovery of a possible defect, of:*
 - (a) The model number and serial number, if any;*
 - (b) The identity of the seller and the approximate date of purchase;*
 - (c) A detailed description of the problem, including details on the electrical connection to associated equipment and the list of such equipment.*
- (3) Deliver the product to the R. L. DRAKE COMPANY or the nearest authorized service facility, or ship the same in its original container or equivalent, fully insured and shipping charges prepaid.*

Correct maintenance, repair and use are important to obtain proper performance from this product. Therefore, carefully read the Instruction Manual. This warranty does not apply to any defect that R. L. DRAKE COMPANY determines is due to:

- (1) Improper maintenance or repair, including the installation of parts or accessories that do not conform to the quality and specifications of the original parts.*
- (2) Misuse, abuse, neglect or improper installation.*
- (3) Accidental or intentional damage.*

All implied warranties, if any, terminate ninety (90) days from the date of the original purchase.

The foregoing constitutes R. L. DRAKE COMPANY'S entire obligation with respect to this product, and the original purchaser and any user or owner shall have no other remedy and no claim for incidental or consequential damages. Some states do not allow limitations on how long an implied warranty lasts or do not allow the exclusion or limitation of incidental or consequential damages, so the above limitation and exclusion may not apply to you.

This warranty gives specific legal rights and you may also have other rights which vary from state to state.

R. L. DRAKE COMPANY
540 Richard Street • Miamisburg, Ohio 45342



TABLE OF CONTENTS

	Page	
CHAPTER I	INTRODUCTION	1-1
1-1.	GENERAL DESCRIPTION	1-1
1-2.	MANUAL COVERAGE	1-1
	SPECIFICATIONS	1-3
CHAPTER II	INSTALLATION	2-1
2-1.	UNPACKING	2-1
2-2.	LOCATION	2-1
2-3.	POWER REQUIREMENTS	2-1
2-4.	GROUND	2-1
2-5.	ANTENNA	2-1
2-6.	MUTE	2-2
2-7.	ANTI VOX	2-2
2-8.	INJECTION	2-2
2-9.	CARRIER OSCILLATOR	2-2
2-10.	PTO LAMP	2-2
2-11.	SPEAKER	2-2
2-12.	ACCESSORY POWER	2-2
2-13.	ACCESSORY CRYSTAL FILTER INSTALLATION	2-2
2-14.	ACCESSORY CRYSTALS	2-2
2-15.	NOISE BLANKER	2-3
2-16.	CONNECTION TO T-4XC TRANSMITTER	2-3
2-17.	CONNECTION TO T-4/T-4X/T-4B/T-4XB TRANSMITTERS	2-3
2-18.	CONNECTION TO TR-4 OR TR-4C	2-3
CHAPTER III	OPERATION	3-1
3-1.	GENERAL	3-1
3-2.	FUNCTION	3-1
3-3.	MODE	3-1
3-4.	MAIN TUNING DIAL	3-1
3-5.	DIAL CALIBRATION	3-1
	FRONT PANEL CONTROLS	3-3
3-6.	XTALS	3-4
3-7.	BAND	3-4
3-8.	PRESELECTOR	3-4
3-9.	PASSBAND TUNING	3-4
3-10.	GAIN	3-4
3-11.	AGC	3-5
3-12.	NOTCH	3-5

TABLE OF CONTENTS (continued)

		Page
3-13.	S METER	3-5
3-14.	PHONE JACK	3-5
3-15.	S METER ZERO	3-5
3-16.	BASIC CONTROL SETTINGS	3-5
3-17.	SSB RECEPTION	3-6
3-18.	CW RECEPTION	3-6
3-19.	AM RECEPTION	3-6
3-20.	RTTY RECEPTION	3-7
3-21.	NOISE BLANKER	3-7
3-22.	ADDITIONAL TUNING RANGES	3-7
CHAPTER IV	THEORY OF OPERATION	4-1
4-1.	GENERAL	4-1
4-2.	RF AMPLIFIER	4-1
4-3.	PREMIXER	4-1
4-4.	FIRST MIXER	4-1
4-5.	FIRST IF SYSTEM	4-1
4-6.	SECOND IF SYSTEM AND DETECTORS	4-2
4-7.	AGC CIRCUIT.	4-2
4-8.	S METER	4-2
4-9.	AUDIO AMPLIFIER	4-2
4-10.	POWER SUPPLY	4-2
4-11.	CRYSTAL CALIBRATOR	4-2
CHAPTER V	MAINTENANCE	5-1
5-1.	SERVICE DATA	5-1
5-2.	MAINTENANCE	5-1
5-3.	COVER REMOVAL	5-1
5-4.	TEST EQUIPMENT REQUIRED	5-1
5-5.	TROUBLESHOOTING	5-1
5-6.	ALIGNMENT INSTRUCTIONS	5-1
5-7.	50 kHz BFO AND IF ALIGNMENT	5-2
5-8.	5645 OSCILLATOR ADJUSTMENT	5-2
5-9.	FILTER MATCH ALIGNMENT	5-2
5-10.	NOTCH FILTER ADJUSTMENT	5-2
5-11.	5595 OSCILLATOR ADJUSTMENT	5-2
5-12.	ANTENNA, RF AND INJECTION ALIGNMENT	5-2
5-13.	S METER ADJUSTMENT	5-3
5-14.	CRYSTAL CALIBRATOR ADJUSTMENT	5-3

LIST OF ILLUSTRATIONS

Figure		Page
1-1.	R-4C RECEIVER	1-2
2-1.	VIEWING ANGLE OPTIONS.	2-5
2-2.	REAR CHASSIS CONTROLS	2-5
2-3.	CONNECTING THE TR-4C	2-3
3-1.	FRONT PANEL CONTROLS.	3-2
3-2.	PRESELECTOR TUNING RANGES	3-7
3-3.	AM SELECTIVITY CURVES.	3-8
3-4.	SSB AND CW SELECTIVITY CURVES	3-9
4-1.	BLOCK DIAGRAM	4-3
5-1.	ALIGNMENT LOCATIONS, TOP VIEW	5-7
5-2.	ALIGNMENT LOCATIONS, BOTTOM VIEW	5-8
	ACCESSORY NOISE BLANKER MODEL 4-NB	5-8
5-3.	SCHEMATIC DIAGRAM	5-9

CHAPTER I

INTRODUCTION

1-1. GENERAL DESCRIPTION.

The R-4C Receiver is a triple conversion superheterodyne receiver designed for optimum reception of all types of amateur radio communications. It provides complete coverage of the 80, 40, 20, and 15 meter amateur bands and 28.5 to 29.0 MHz of the 10 meter band with the crystals supplied. Additional coverage of 500 kHz segments between 1.5 and 30 MHz is possible with the addition of accessory range crystals. Sockets are provided for up to 15 additional crystals. A highly linear permeability-tuned solid state VFO and premixed injection give excellent stability and dial calibration on all bands. Eight pole crystal filter selectivity combined with passband tuning and a tunable notch filter provide superior interference rejection. Three AGC time constants are selectable from the front panel and a 25 kHz crystal calibrator provides convenient markers at 25 kHz intervals throughout

the frequency range of the receiver.

1-2. MANUAL COVERAGE.

This manual is presented in 5 chapters and is arranged for the convenience of the operator and service technician as follows:

- | | |
|-------------|--|
| Chapter I | Introduction (self explanatory). |
| Chapter II | Installation. Describes the procedures to be followed prior to operation. |
| Chapter III | Operation. Illustrates and describes front panel controls and describes operation in SSB, CW and AM modes. |
| Chapter IV | Theory of Operation. Describes all critical circuits and networks. |
| Chapter V | Maintenance. Provides maintenance instructions and parts ordering information. |



Figure 1-1. R-4C Receiver

SPECIFICATIONS

Frequency Coverage:	Covers 3.5 to 4.0 MHz, 7.0 to 7.5 MHz, 14.0 to 14.5 MHz, 21.0 to 21.5 MHz, and 28.5 to 29.0 MHz.
Accessory Coverage:	15 accessory crystal sockets are provided. Coverage of any additional 500 kHz ranges between 1.5 and 30 MHz (except between 5.0 and 6.0 MHz) can be added by installing accessory crystals.
Modes of Operation:	SSB, CW, AM, RTTY.
Sensitivity:	SSB Mode: 10 dB signal-plus-noise to noise ratio obtained on 80 M-10 M amateur bands with less than a 0.25 microvolt signal on the antenna terminal, on other frequencies less than 0.5 microvolt signal.
Selectivity:	As supplied: SSB Mode: 2.4 kHz at 6 dB, 4.2 kHz at 60 dB. AM Mode: 8.0 kHz at 6 dB, 28 kHz at 60 dB. With accessory crystal filters: AM Mode, 2 filters available: 6.0 kHz at 6 dB, 10 kHz at 60 dB. 4.0 kHz at 6 dB, 7.5 kHz at 60 dB. CW 1.5, CW .5, CW .25 Modes, 3 filters available: 1.5 kHz at 6 dB, 3.0 kHz at 60 dB. 500 Hz at 6 dB, 1000 Hz at 60 dB. 250 Hz at 6 dB, 600 Hz at 60 dB.
Stability:	After warm up, frequency will not drift more than ± 100 Hz, including voltage variation of $\pm 10\%$.
Calibration:	Better than ± 1 kHz when calibrated at nearest 100 kHz calibration point.
Spurious Responses:	Internal spurious response less than the equivalent of a 1 microvolt antenna signal on all amateur bands.
Image Rejection:	(11.29 MHz above desired): Over 70 dB below 23 MHz, 60 dB above 23 MHz.
Input Impedance:	52 Ohms nominal.
Audio Output Impedance:	3.2 Ohms to speaker, or headphones, 3000 Ohms anti vox.
Audio Output:	0.7 Watt at AVC threshold, 2 Watts maximum at less than 5% T.H.D.
AGC:	Audio Output increases 3 dB maximum for a RF input increase of 100 dB above AGC threshold. AGC threshold typically 1 microvolt. Attack time: 1 millisecond Release times: Slow: 1 second Medium: 350 mSec Fast: 50 mSec
Power Consumption:	60 Watts, 120/240 Volts AC, 50/60 Hz.
Size:	5.5 inches high, 10.75 inches wide, 12.25 inches deep overall.
Weight:	17 pounds.

NOTES

CHAPTER II

INSTALLATION

2-1. UNPACKING.

Carefully remove the receiver from the shipping carton and examine it for evidence of damage. If any damage is discovered, immediately notify the transportation company that delivered the receiver. Be sure to keep the shipping carton and packing material, as the transportation company will want to examine them if there is a damage claim. Keeping the carton and packing is recommended in any case, as having these available makes packing the receiver much easier should it ever be necessary to store it or return it to the factory for service. Inspect the packing material before putting it away to be sure you have not overlooked any accessory hardware. The hardware consists of two studs, No. 10-24, 5/8 inch long, and two small rubber feet. Examine your R-4C to make sure that all tubes and crystals are properly seated in their sockets.

NOTE

Fill out the enclosed registration card and return it to the factory immediately to insure registration and validation of the warranty.

2-2. LOCATION.

The location of the R-4C is not critical, as long as allowance is made for adequate air circulation. Avoid extremely hot locations. It is recommended that a minimum clearance of one inch be maintained at each side of the R-4C. Do not cover the top with books, paper, or pieces of equipment.

With the studs and rubber feet supplied, it is possible to position the R-4C for either of two alternate viewing angles, as shown in figure 2-1. To convert the R-4C to either option, the first step is to remove the bottom cover from the receiver. Remove the bottom row of three screws on each side of the receiver, and the cover can be removed. Remove the rear feet, and snap the small rubber feet into the holes just outboard from the original

rear feet. For option B, put the bottom cover back on the receiver. For option C, remove the front feet from the receiver, invert them, and remount them on the same screws. Then thread one of the accessory studs into each of the remounted front feet. Finally, mount the feet that were removed from the rear of the receiver on the studs, and put the bottom cover back onto the receiver.

2-3. POWER REQUIREMENTS.

CAUTION

Operation of this receiver with the wrong power source may result in serious damage.

Refer to figure 2-2. As shipped from the factory the R-4C is wired for 120 Volt 50/60 Hz AC operation. The receiver may also be operated from 240 V AC by removing the retaining tab and placing the 120/240 Volt slide switch on the rear panel in the 240 Volt position. Replace the retaining tab on the opposite mounting screw to prevent the switch from accidentally being returned to the 120 V position. Operation of the receiver from 240 V with the switch in the 120 V position will cause serious damage.

2-4. GROUND.

A screw terminal is provided on the rear panel for connection to the station ground. Also, if used with the T-4XC transmitter and other accessories, connect a ground strap between the ground terminals of all units.

2-5. ANTENNA.

The jack labeled ANT is the connection point for the antenna. The nominal impedance of the circuit is 52 Ohms.

2-6. MUTE.

The MUTE jack provides connections for external standby-receive switching. The external circuit must isolate the MUTE jack center conductor from ground for standby, and connect it to the MUTE jack ground for receive. The R-4C is shipped with a shorted phono plug in this jack. When used with a transmitter, remove the shorted plug and connect the appropriate cable to the transmitter MUTE jack.

2-7. ANTI VOX.

High impedance audio is available at the ANTI VOX jack for use with the anti vox circuit of the transmitter.

2-8. INJECTION.

The phono jack marked INJ. provides a means of coupling the pre-mixer system of the R-4C to the Drake T-4, T-4B, T-4C, T-4X, T-4XB or T-4XC transmitters for transceive operation.

2-9. CARRIER OSCILLATOR.

The jack marked CAR. OSC provides a means of coupling injection from the T-4XC carrier oscillator to the R-4C receiver. This connection phase-locks the two units to exactly the same frequency when used in the SSB Transceive mode. No connection is made to this jack for use with the T-4X or T-4XB transmitter.

2-10. PTO LAMP.

This jack provides a ground return for the pilot lamp behind the PTO dial. The R-4C is shipped with a shorted phono plug in this jack so that the lamp will light. When the R-4C is used with the T-4XC transmitter, remove the shorted phono plug and connect a cable between the PTO lamp jacks of the two units. The lamp will then light only when the T-4XC TRANSCEIVE switch is in the RCVR, SEPARATE, or SPOT positions. In the XMTR position, the lamp will not light to indicate that the R-4C PTO is disabled.

2-11. SPEAKER.

The audio output from the receiver is available at the jack marked SPKR. The output impedance is 3.2 Ohms.

2-12. ACCESSORY POWER.

The accessory power socket, labeled ACCY POWER, located on the rear of the chassis, provides power for operating accessories. Maximum load is 6.3 Volts AC at 300 milliamperes and 12 Volts DC at 50 milliamperes. A connection to the antenna is also available. The socket mates with a Cinch type 5AB2 plug.

2-13. ACCESSORY CRYSTAL FILTER INSTALLATION.

To install additional crystal filter(s), proceed as follows: Remove the two screws holding the filter cover bracket for each position in which a filter is being installed. The upper position is for the .250 kHz filter, the center position is for the .500 kHz filter, and the lower position is for the 1.5 kHz filter. If a filter for the AM mode is being installed, remove the top cover of the R-4C, the mode switch cover and remove the filter cover bracket and the 150 Ohm jumper resistor from the AM filter socket. Very carefully plug each filter straight into the sockets.

After installing all the filters desired, replace the cover brackets over each filter and tighten the mounting screws. Do not attempt to use accessory filters without installing the brackets as it is very important to have a solid ground connection between the bottom of the filter and the spring material.

2-14. ACCESSORY CRYSTALS.

By inserting the appropriate crystals in the accessory crystal sockets at the top rear of the chassis, it is possible to add up to 15 additional tuning ranges (each 500 kHz wide) to the coverage of the R-4C. With the exception of the band from 5.0 to 6.0 MHz, these additional ranges may be anywhere between 1.5 and 30 MHz. Only series resonant crystals

should be used for accessory coverage. Selected crystals for accessory coverage with the R-4C will be supplied by the R. L. Drake Company at a nominal cost. Contact Customer Service Department at the address given in paragraph 5-1 for price and delivery information. To determine the correct crystal frequency for any additional range, see table 2-1 which shows the required crystal frequency and the proper BAND switch setting for the R-4C for the frequency spectrum from 1.5 to 30 MHz, except for the 5.0 to 6.0 MHz range. However, if you are going to transceive with the Drake T-4, T-4B, T-4C, T-4X, T-4XB, or T-4XC, the crystal selection table in the transmitter manual should be followed in selecting accessory crystals.

Remove the screws holding the shield/cover over the 15 accessory crystal sockets on the rear panel. Install the desired crystals and replace the cover and its mounting screws.

2-15. NOISE BLANKER.

To install the optional 4-NB Noise Blanker, remove the top row of three screws on each side of the R-4C. Remove the cabinet top. Remove the jumper plug from the noise blanker socket which is located toward the rear of the receiver, on top of the chassis. Retain the jumper plug so that it may be used if the 4-NB should ever require service. The 4-NB mounts on the four plastic stand-offs which are on the metal shields on either side of the PTO. Align the plastic stand-offs with the four holes in the 4-NB circuit board with the 4-NB cable toward the rear of the R-4C. Carefully push the 4-NB onto the stand-offs until it snaps into place. Dress the 4-NB cable toward the rear of the receiver and through the notch in the filter shield just above the NB socket and under the mode switch cover. Plug the 4-NB into the NB socket of the R-4C.

Turn on the receiver and tune in the crystal calibrator signal. Detune the PRESELECTOR until calibrator signal S meter reading is around S5. Temporarily unplug the 4-NB cable and reinstall the jumper plug. Compare S meter readings. If the gain varies more than 1/2 S unit between the 4-NB and the jumper plug, adjust R12 (blue potentiometer on 4-NB) until S meter readings are equal when switching between the 4-NB and the jumper plug. Replace cabinet top.

2-16. CONNECTION TO T-4XC TRANSMITTER.

For interconnection diagram see the T-4XC instruction manual.

2-17. CONNECTION TO T-4/T-4X/T-4B/T-4XB TRANSMITTERS.

Connect as indicated in the transmitter instruction manual. No connection will be made to the CAR OSC jack and the shorted phono plug should be left in the PTO LAMP jack. Follow the instructions in the transmitter manual for Transceive Alignment if necessary. When making the adjustment, set the R-4C PASSBAND TUNING at 12 o'clock and the MODE Switch to SSB. Other control settings are the same as stated for the R-4/R-4B. The adjustment on the R-4C is C59 located on a PC board on the top of the R-4C chassis (see figure 5-1). Adjust this capacitor for zero canary chirps.

2-18. CONNECTION TO TR-4 OR TR-4C.

To use the R-4C as an external receiver with the TR-4/TR-4C transceiver, make the connections illustrated in figure 2-3.

Table 2-1. Crystal Frequency Chart

FREQUENCY RANGE	CRYSTAL	BAND	FREQUENCY RANGE	CRYSTAL	BAND
1.5 – 2.0	12.6	1.5 – 3.0	16.5 – 17.0	27.6	21.0
2.0 – 2.5	13.1	1.5 – 3.0	17.0 – 17.5	28.1	21.0
2.5 – 3.0	13.6	1.5 – 3.0	17.5 – 18.0	28.6	21.0
3.0 – 3.5	14.1	3.5	18.0 – 18.5	29.1	21.0
3.5 – 4.0	14.6*	3.5	18.5 – 19.0	29.6	21.0
4.0 – 4.5	15.1	3.5	19.0 – 19.5	30.1	21.0
4.5 – 5.0	15.6	3.5	19.5 – 20.0	30.6	21.0
6.0 – 6.5	17.1	7.0	20.0 – 20.5	31.1	21.0
6.5 – 7.0	17.6	7.0	20.5 – 21.0	31.6	21.0
7.0 – 7.5	18.1*	7.0	21.0 – 21.5	32.1*	21.0
7.5 – 8.0	18.6	7.0	21.5 – 22.0	32.6	21.0
8.0 – 8.5	19.1	7.0	22.0 – 22.5	33.1	21.0
8.5 – 9.0	19.6	7.0	22.5 – 23.0	33.6	21.0
9.0 – 9.5	20.1	7.0	23.0 – 23.5	34.1	28.5
9.5 – 10.0	20.6	7.0	23.5 – 24.0	34.6	28.5
10.0 – 10.5	21.1	14.0	24.0 – 24.5	35.1	28.5
10.5 – 11.0	21.6	14.0	24.5 – 25.0	35.6	28.5
11.0 – 11.5	22.1	14.0	25.0 – 25.5	36.1	28.5
11.5 – 12.0	22.6	14.0	25.5 – 26.0	36.6	28.5
12.0 – 12.5	23.1	14.0	26.0 – 26.5	37.1	28.5
12.5 – 13.0	23.6	14.0	26.5 – 27.0	37.6	28.5
13.0 – 13.5	24.1	14.0	27.0 – 27.5	38.1	28.5
13.5 – 14.0	24.6	14.0	27.5 – 28.0	38.6	28.5
14.0 – 14.5	25.1*	14.0	28.0 – 28.5	39.1	28.5
14.5 – 15.0	25.6	14.0	28.5 – 29.0	39.6*	28.5
15.0 – 15.5	26.1	14.0	29.0 – 29.5	40.1	28.5
15.5 – 16.0	26.6	14.0	29.5 – 30.0	40.6	28.5
16.0 – 16.5	27.1	21.0			

*Supplied with receiver

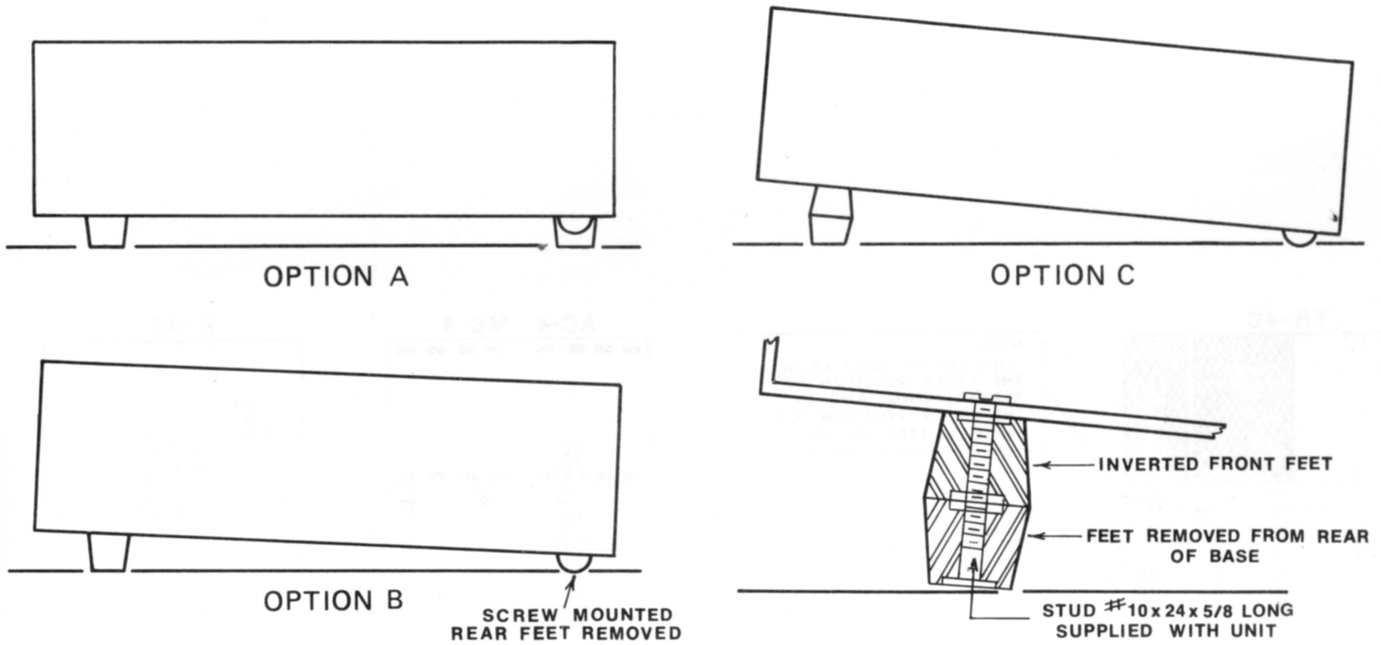

Figure 2-1. Viewing Angle Options

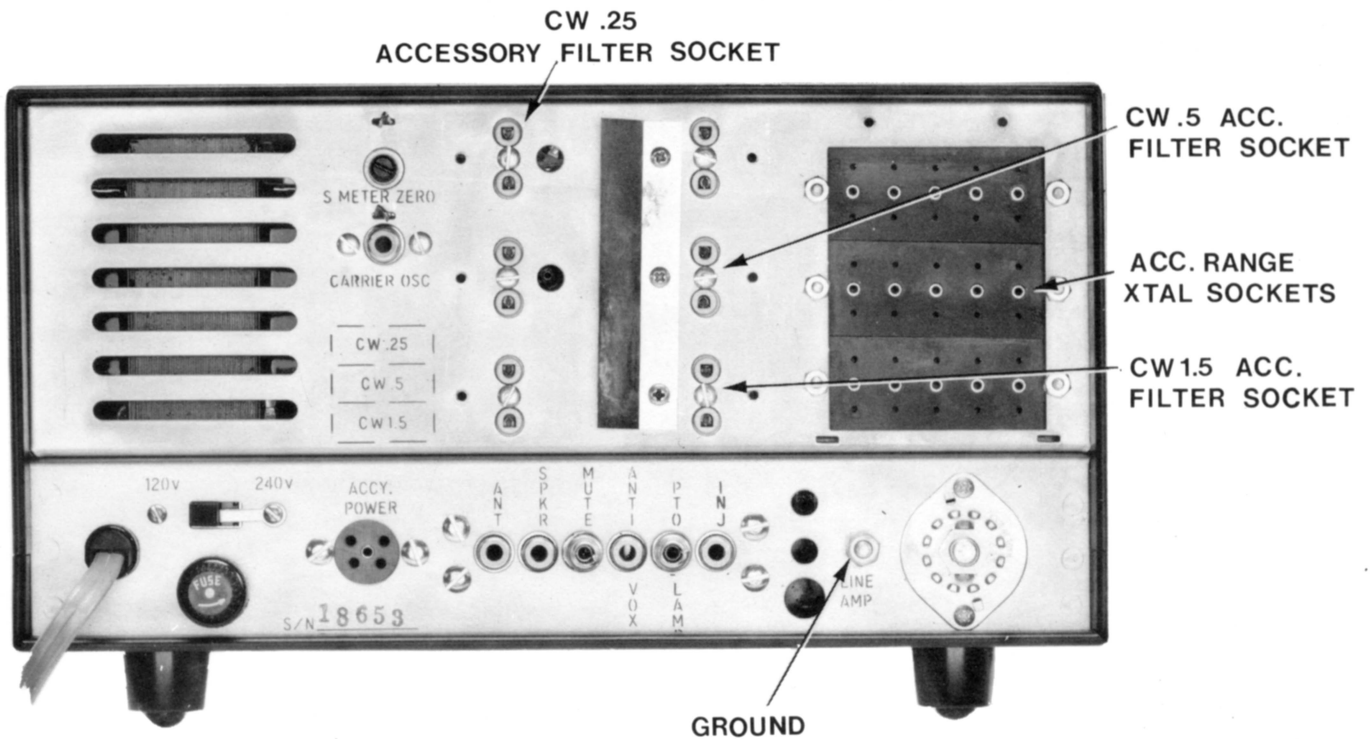

Figure 2-2. Rear Chassis Controls

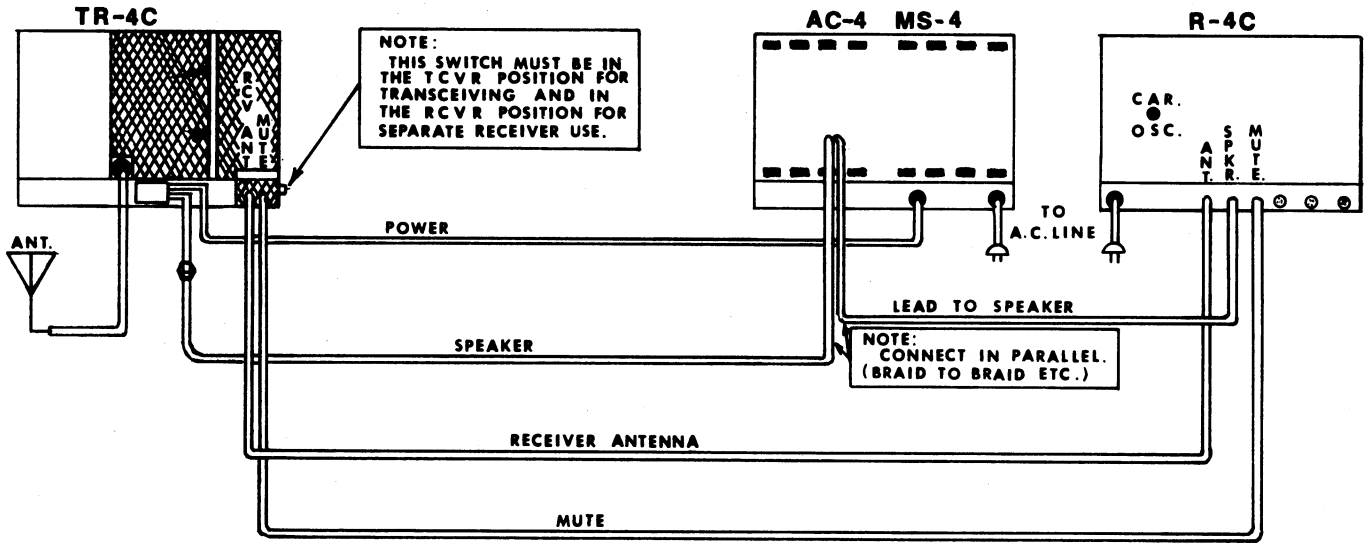

Figure 2-3. Connecting the TR-4C Transceiver

CHAPTER III OPERATION

3-1. GENERAL.

Figure 3-1 illustrates and describes the front panel controls. Refer to the text in this chapter for detailed operating instructions. Rear chassis connectors are identified in figure 2-2.

3-2. FUNCTION.

With the FUNCTION switch in the OFF position, the primary of the power transformer is disconnected from the line cord. In the standby (STBY) position all operating voltages are applied to the receiver circuits, but the receiver is muted. With the switch in the ON position, the receiver operates unmuted regardless of external muting connections. The EXT. MUTE position is the same as the ON position, except that receiver muting is externally controlled through the MUTE jack on the rear of the chassis. Switching to the NB position energizes the accessory Noise Blanker, when it has been installed, without changing the muting function. Switching to the CAL position energizes the 25 kHz Crystal calibrator without changing the muting function. If external muting is not used, the shorting plug (supplied with the R-4C) must be inserted into the Mute jack in order to obtain NB and CAL operation.

3-3. MODE.

The MODE switch determines the desired selectivity and selects the proper detectors. In the AM position, the AM detector is switched in. The IF bandpass of the receiver is 8 kHz as determined by the 4 pole 1st IF crystal filter and the two 50 kHz tuned circuits. For additional selectivity an accessory AM 8 pole filter can be installed in the internal accessory filter socket in place of the 150 Ohm resistor which is supplied. The selectivity then has 8 pole response in the AM mode. The Passband Tuning is inoperative in AM mode. In the SSB mode, the product detector is used. The 2.4 kHz,

8 pole crystal filter which is mounted internally determines the selectivity. This mode is used for normal SSB reception and can also be used for CW and RTTY.

In the CW 1.5, CW .5 and CW .25 modes, the product detector is used. Selectivity is determined by the accessory filter(s) which are installed in the sockets on the rear panel. The passband tuning is operative in the SSB and the three CW modes. Note that the receiver will not operate in the CW 1.5, CW .5, or CW .25 mode until a filter is installed in the appropriate rear panel socket.

3-4. MAIN TUNING DIAL.

This dial has 2 transparent discs which display concentric scales and which rotate at different speeds. Zero to 100 kHz is indicated on one disc and hundreds of kHz is indicated on the other. The frequency of the operating signal is the sum of the frequencies indicated by the BAND switch and the Main Tuning Dial, for example:

BAND switch setting	7.000 MHz
100 kHz dial	.200 MHz
1 kHz dial	<u>.026 MHz</u>
Received frequency	7.226 MHz

3-5. DIAL CALIBRATION.

The Main Tuning Dial may be calibrated by the following procedure:

- Set the FUNCTION switch to CAL and set the PASSBAND TUNING control to 12 o'clock.
- Tune the R-4C to zero beat with the nearest 25 kHz calibrator signal.
- Hold the knob on the Main Tuning control stationary and rotate the knob skirt until the dial displays the correct frequency.

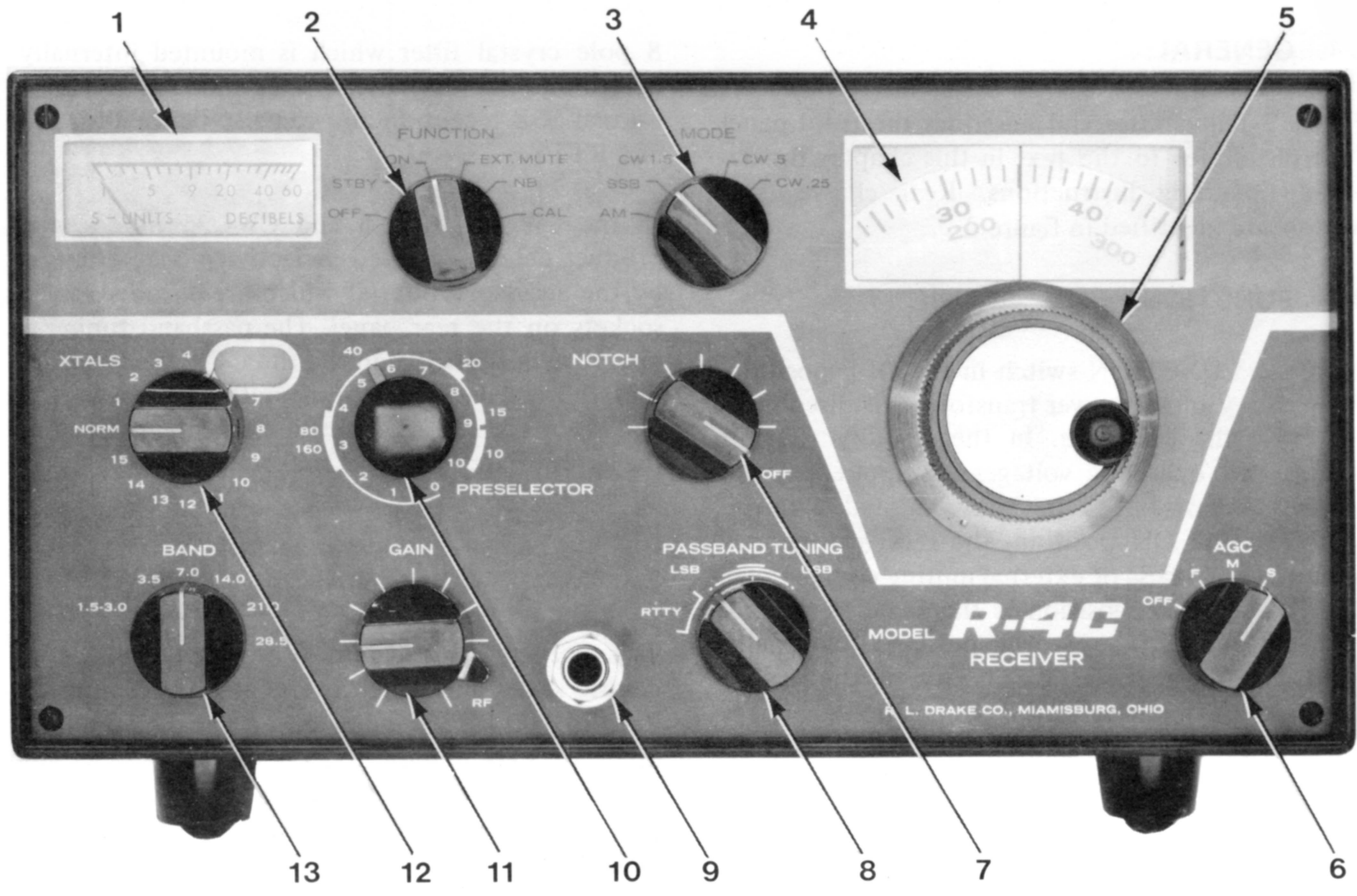

Figure 3-1. Front Panel Controls

FRONT PANEL CONTROLS

1. **S Meter:** Indicates relative signal strength. Calibrated in S units from 1 to 9. Above 9 the scale is calibrated in decibels.
2. **FUNCTION Switch:** Selects standby, external mute and crystal calibrator functions and switches in the Model 4—NB Noise Blanker. Also turns the Receiver on and off.
3. **MODE Switch:** Selects Receiver operating mode.
4. **Main Tuning Dial:** Displays a portion of the received frequency from zero to 500 kHz. The reading must be added to the BAND switch setting to determine the exact frequency.
5. **Main Tuning Control:** Adjusts frequency setting of the Main Tuning Dial.
6. **AGC Switch:** Selects the release time constant of the automatic gain control circuit (slow: S; medium: M; fast: F) or turns off the AGC.
7. **NOTCH Control:** Attenuates heterodyne interference in all modes of reception.
8. **PASSBAND TUNING Control:** Adjusts the positioning of the BFO in SSB and CW modes.
9. **Phone Jack:** Provides a connection for headphones.
10. **PRESELECTOR Control:** Tunes the antenna, RF and pre-mixer coupling coils.
11. **GAIN Control:** Knob adjusts AF gain. Lever controls RF gain (normally in full clockwise position).
12. **XTALS Switch:** Selects accessory crystals for accessory band operation (15 positions). NORM position transfers crystal selection function to BAND switch for amateur band operation.
13. **BAND Switch:** Selects amateur band desired when XTALS switch is in NORM position. Also selects proper RF circuits for accessory crystal operation (refer to table 2-1 for correct setting).

3-6. XTALS.

In the NORM setting of this 16 position switch, the proper crystal for reception of the various amateur bands is selected by the BAND switch (except at the 1.5 setting). The numbered positions of this switch correspond to the accessory crystal sockets mounted at the rear of the receiver. When the switch is set to a numbered position, the crystals in the socket having the same number will be connected to the circuit for accessory band operation. (The range window, just to the right of the XTALS control, provides a convenient place to write in the frequency covered in each accessory band). The band switch must then be operated in accordance with table 2-1.

3-7. BAND.

This six position switch selects the amateur band desired during normal operation. It also is used to select the proper RF circuits for the various tuning ranges when use is made of accessory crystals for other frequency ranges. Correct setting of the BAND switch during accessory operation is shown in table 2-1.

3-8. PRESELECTOR.

Rotation of this control changes the tuning of the antenna, RF, and pre-mixer coupling coils. The outer ring of numbers, around the base of this control indicates the general setting for the various bands. Fine adjustment for peak reception is made after the signal is tuned in. A scale calibrated from 0 through 10 is provided for logging. See figure 3-2 for setting for out-of-amateur-band operation.

3-9. PASSBAND TUNING.

The PASSBAND TUNING control adjusts the positioning of the BFO with respect to the receiver passband but without changing the frequency to which the receiver is tuned. This control operates in the SSB, CW 1.5, CW .5, CW .25 modes. The curved lines above the knob indicate the relative bandwidths and positions of the passbands. The

knob pointer indicates the position of the BFO with respect to the passband. The longest line indicates the passband width of the 2.4 kHz filter used in the SSB mode. The dot at the left end of this line shows the normal setting of the BFO with respect to the passband for LSB reception. The dot at the right end of this line shows the normal positioning of the BFO for USB reception. However, to emphasize lower audio frequencies and reduce high pitched interference, the control may be adjusted slightly closer to the passband (toward 12 o'clock position). Conversely, to emphasize higher frequencies the PASSBAND TUNING control may be set to position the BFO slightly farther away from the passband than the dot indicates. Note that because the received frequency is not changed when the PASSBAND TUNING control is moved, selection of USB or LSB with this control is possible with no retuning of the PTO to keep the receiver tuned to the same carrier frequency. Careful adjustment of this control can result in markedly improved reception under heavy interference conditions. When the 1.5 kHz crystal filter has been installed in the CW 1.5 mode, the second longest line indicates the relative width and position of this filter passband. Again the PASSBAND TUNING knob shows the position of the BFO with respect to this passband. When the 500 Hz or 250 Hz filter has been installed in the CW .5 or CW .25 position, the shortest line above the PASSBAND TUNING knob is used. When tuning in a CW signal, the received signal will be centered in the passband. The BFO frequency (as indicated by the relative position of the PASSBAND TUNING) must be offset by the amount needed to produce the desired beat frequency. Normally the correct setting will be just beyond either the left or right end of the line corresponding to the bandwidth of the filter in use. For higher beat note frequencies, the knob must be moved farther beyond the end of the passband line. For RTTY reception of 2125 and 2975 tone frequencies, the PASSBAND TUNING control should be in the RTTY area.

3-10. GAIN.

The GAIN control consists of two concentric controls. The inner control is the AF Gain and is adjusted with the knob. The AF Gain control varies the audio output from the receiver by varying the

audio voltage applied to the audio amplifier stages. The outer control which is adjusted with the lever is the RF Gain control. This control increases the AGC threshold or bias level on the RF and IF stages which prevents signals below a certain level from being received. Normally this control should remain in the full clockwise position.

3-11. AGC.

This switch selects the release time constant of the automatic gain control circuit or turns off the AGC. In the OFF position, the receiver gain may be controlled manually with the RF gain control. In the F (fast release), M (medium release), or S (slow release) positions, the AGC is operative. The release time constant is approximately 1 second in the S position, 350 milliseconds in the M position, and 50 milliseconds in the F position. Attack time is 1 millisecond in F, M, S modes.

3-12. NOTCH.

The NOTCH control can be used effectively in all modes of reception for attenuation of heterodyne interference from a carrier near the desired carrier. A permeability-tuned T-notch filter in the 50 kHz IF is used for this purpose. The filter produces a deep notch which can be tuned across the IF by rotation of the NOTCH control knob. On any mode of operation, an unwanted carrier is attenuated by tuning the notch across the receiver passband until the unwanted carrier is removed by the notch filter. Since the notch filter will remove the wanted carrier just as readily as an unwanted carrier, the NOTCH control must be *adjusted carefully* for maximum effectiveness. In the SSB, CW 1.5, CW .5, or CW .25 modes, the PASSBAND TUNING will also affect the NOTCH frequency. Therefore, the PASSBAND TUNING control should be set before the NOTCH control is adjusted. However, after obtaining a notch, the PASSBAND TUNING may be moved slightly to fine tune the notch for maximum null. When a notch is not needed, the NOTCH control should be returned to the detent in the OFF position.

3-13. S METER.

The S Meter indicates relative signal strength, and is a convenient indicator for peaking the tuning of the receiver. The lower (left hand) portion is calibrated in S units from S-1 through S-9. Above S-9 the scale is calibrated in decibels. Each S unit is equal to approximately 5 dB. An S-9 signal is approximately 30 microvolts input to the antenna jack.

3-14. PHONE JACK.

The phone jack is used when private listening is desired. Connection of the headphones automatically mutes the speaker output. While headphone impedance is not critical, a good quality set of 600 Ohm phones will work well. If 8 Ohm headphones are used, a pad should be connected between the phone jack and the phones to reduce the audio power to a reasonable level for the phones. Normally connecting a 100 Ohm resistor in series with the 8 Ohm headphones will provide adequate attenuation.

3-15. S METER ZERO.

NOTE

The antenna should be disconnected from the R-4C while making this adjustment.

The S meter zero control is on the rear panel of the R-4C. It may be used to set the S meter needle to S-1 under no-signal conditions.

3-16. BASIC CONTROL SETTINGS.

For operation in any mode, preset the following controls as indicated:

- a. Set FUNCTION switch to ON.
- b. Set BAND switch to Desired Amateur Band.
- c. Set XTALS switch to NORM.
- d. Set NOTCH control to OFF.
- e. Set RF GAIN lever fully clockwise.

- f. Set AF GAIN knob to a comfortable level.
- g. Set PRESELECTOR control to center of band segment marked on panel. After desired signal is tuned in, adjust for maximum S meter reading.

3-17. SSB RECEPTION.

- a. Make the basic control settings listed above.
- b. Set MODE switch to SSB.
- c. Set PASSBAND TUNING to the dot at either the LSB or USB position as desired.
- d. Set AGC switch to S.
- e. Tune in station with Main Tuning knob.
- f. Adjust PRESELECTOR for maximum S meter reading.

After tuning in a station as described above, additional adjustments may be made to further improve reception under various conditions or operator preferences.

- g. Normally the AGC time constant S is optimum for SSB but for rapidly changing signal conditions, it may be desirable to switch to the AGC release time constant M. The F or OFF positions will not normally be desirable for SSB reception.
- h. The PASSBAND TUNING control may be adjusted slightly away from the dot at the LSB or USB position to emphasize low or high frequencies. The fine adjustment of this control is largely one of operator preference, and the setting should be the one which produces the most pleasing audio response or minimum interference.
- i. Under extremely adverse interference conditions the 1.5 kHz bandwidth crystal filter may be used to advantage for SSB reception if this accessory filter has been installed. Careful adjustment of the PASSBAND TUNING control will aid in the effective use of this restricted bandwidth for SSB reception.
- j. The NOTCH control may be used to attenuate an interfering heterodyne. See paragraph 3-12 for adjustment of this control.
- k. If impulse type noise interference is a problem, the accessory 4-NB Noise Blanker may be installed. The Noise Blanker may then be activated by placing the FUNCTION switch in the NB position.

3-18. CW RECEPTION.

- a. Make the basic control settings listed in paragraph 3-16.
- b. Set the MODE switch to SSB if the 2.4 kHz bandwidth filter is desired. If one of the narrower bandwidth accessory crystal filters has been installed it may be selected with the MODE switch.
- c. Set the PASSBAND TUNING to the dot at LSB or USB if the SSB mode is used. If the 1.5 kHz accessory bandwidth is used, set this control just beyond one end of the second longest line. If the 500 Hz or 250 Hz filter is used, set the PASSBAND TUNING just beyond one end of the shortest line.
- d. Set the AGC switch to S.
- e. Tune in a CW signal with Main Tuning knob for maximum S meter reading.
- f. Adjust PRESELECTOR for maximum S meter reading.

After tuning in a station as described above, additional adjustments may be made as follows:

- g. If a different frequency beat note is desired, retune the MAIN TUNING for desired beat note while keeping the signal peaked for maximum strength with the PASSBAND TUNING control.
- h. Faster AGC release time constants may be selected with the AGC control. If desired, the AGC may be switched OFF and the gain controlled manually with the RF GAIN lever.
- i. The NOTCH control may be used to attenuate interfering undesired heterodynes. See paragraph 3-12 for adjustments of this control.
- j. The accessory 4-NB Noise Blanker may be used if impulse noise interference is a problem.

3-19. AM RECEPTION.

- a. Make the basic control settings listed in paragraph 3-16.
- b. Set MODE switch to AM.
- c. Tune in station for maximum S meter indication.
- d. Peak PRESELECTOR for maximum signal strength.

- e. Medium or Fast AGC time constant may be used if desired.
- f. Additionally, the NOTCH filter may be used if necessary to attenuate interfering heterodynes. See paragraph 3-12.
- g. The 4-NB Noise Blanker may be used if impulse noise interference is a problem. The 4-NB will function on AM as well as SSB/CW.

3-20. RTTY RECEPTION.

- a. Make the basic control settings listed in paragraph 3-16.
- b. Set MODE switch to SSB; or, if the 1.5 kHz filter has been installed, this position may be used. Also, if the 500 Hz filter has been installed, this filter may be used for narrow shift RTTY reception.
- c. Set PASSBAND TUNING to the RTTY region. Make fine adjustment for optimum reception.
- d. Tune in station with MAIN TUNING knob.
- e. Adjust PRESELECTOR for maximum S meter indication.
- f. It may be desirable to use the M or F AGC time constant.
- g. The NOTCH control may be used to attenuate interfering heterodynes. See paragraph 3-12.

- h. The 4-NB Noise Blanker may be used if it has been installed.

3-21. NOISE BLANKER.

This accessory is activated by placing the FUNCTION switch in the NB position. The Model 4-NB Noise Blanker can be used on any type of reception. It is most effective on short duration noise impulses such as those generated by automotive ignition systems. Refer to paragraph 2-15 for installation instructions.

3-22. ADDITIONAL TUNING RANGES.

By inserting the appropriate crystals in the accessory crystal sockets at the top rear of the chassis, it is possible to add up to 15 additional tuning ranges (each 500 kHz wide) to the coverage of the R-4C. With the exception of the band from 5.0 to 6.0 MHz, these additional ranges may be anywhere between 1.5 and 30 MHz. In order to receive with an accessory crystal, the XTAL switch of the R-4C must be set to the number corresponding to the accessory crystal socket into which the crystal was plugged. The lowest frequency of the accessory range may then be marked in the range window for reference. The marking is easily erased when crystals are changed. Refer to figure 3-2 for the recommended tuning range for each band.

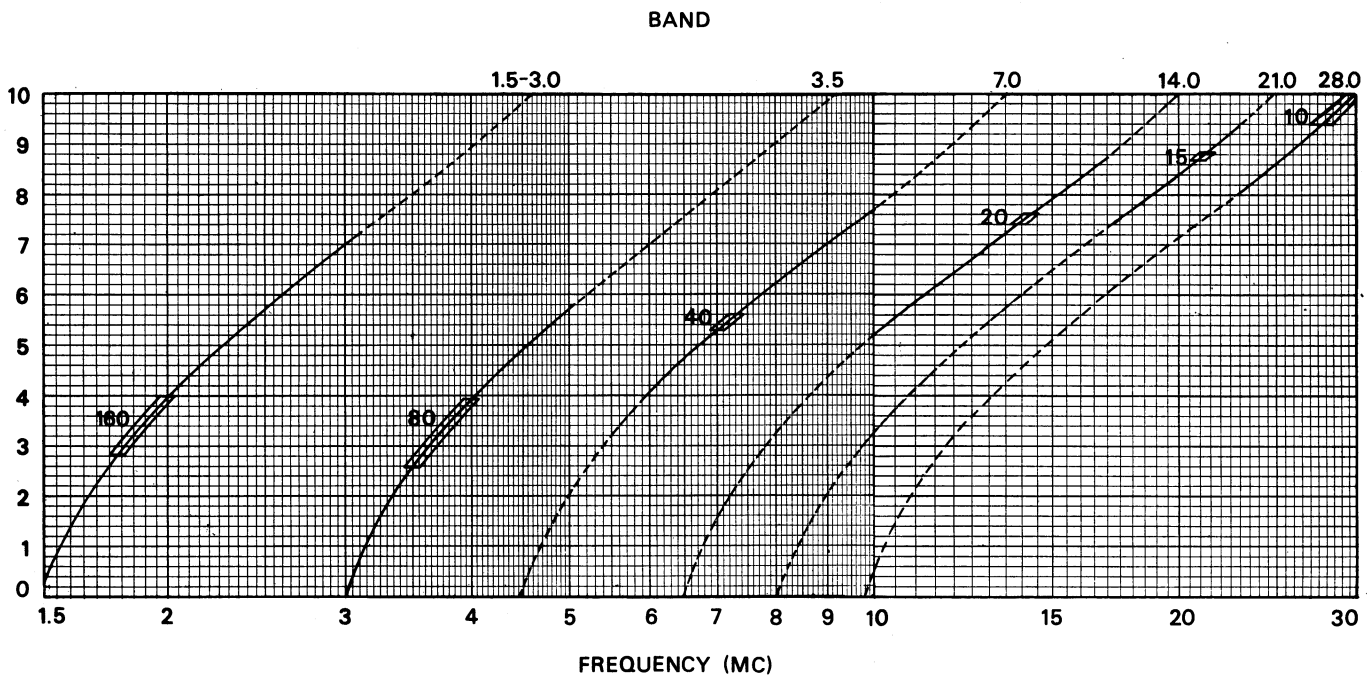

NOTE: SOLID LINE INDICATES RECOMMENDED RANGE FOR EACH BAND.

Figure 3-2. Preselector Tuning Ranges

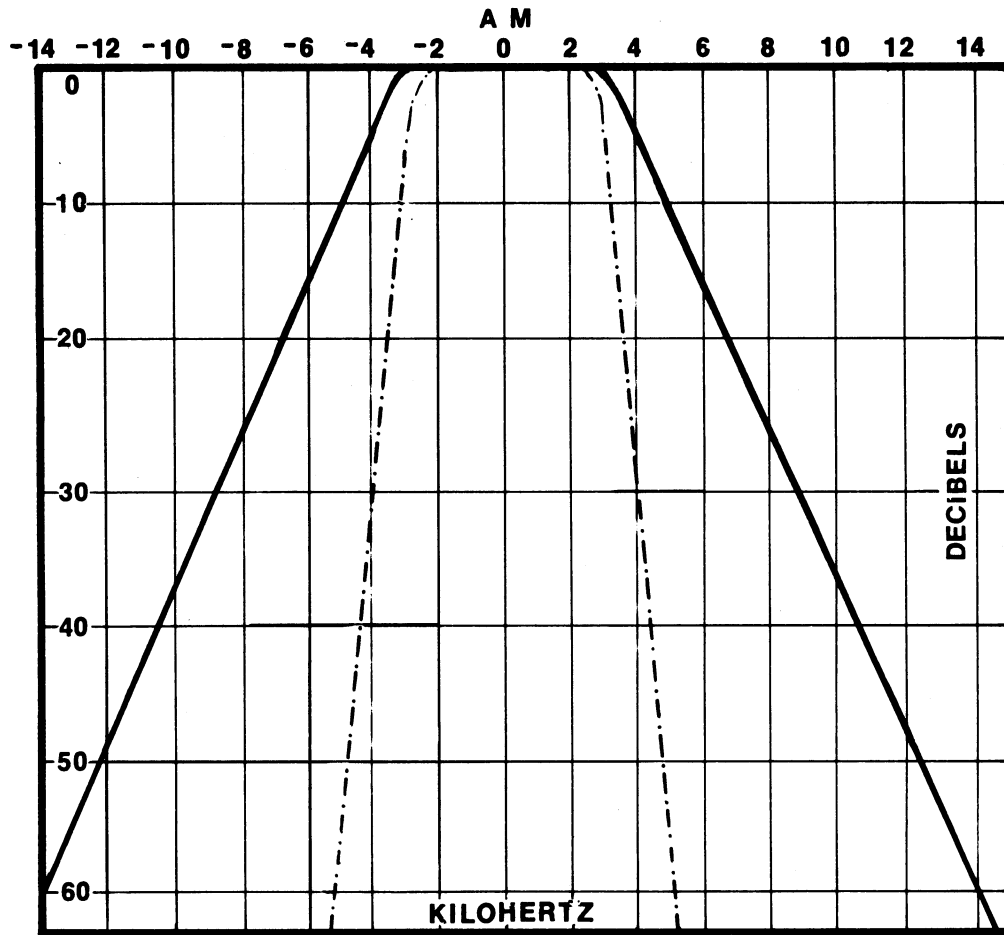

AM SELECTIVITY CURVES

8 KHz —————
 *6 KHz - - - - -

*With optional 6 KHz
 filter installed.

Figure 3-3. AM Selectivity Curves

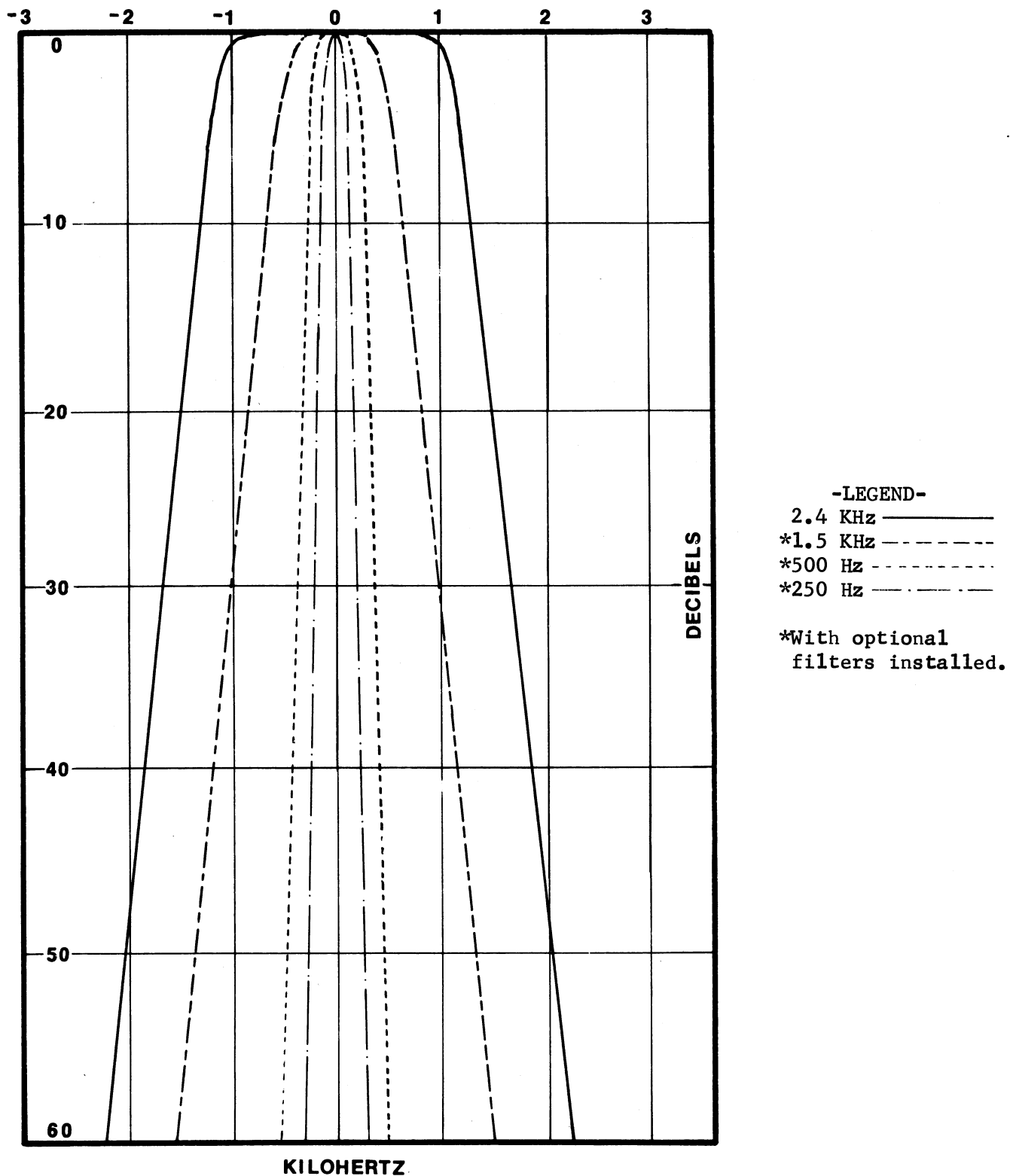

Figure 3-4. SSB and CW Selectivity Curves

NOTES

CHAPTER IV

THEORY OF OPERATION

4-1. GENERAL.

Refer to the block diagram figure 4-1 and the schematic diagram figure 5-3 as required for the following circuit descriptions.

4-2. RF AMPLIFIER.

Signals from the antenna are fed from J1 (ANT.) to permeability-tuned transformer T1, and are applied to the grid of V1 through the tuned circuit formed by T1 and capacitors C1 through C12. The amplified signal is coupled from the plate of V1 to the grid of V2 through the tuned circuit formed by permeability-tuned coil T2 and capacitors C18 through C28.

4-3. PREMIXER.

The premixer system includes a transistorized permeability-tuned VFO, crystal-controlled oscillator Q12, premixer tube V6, and the output circuitry consisting of T3 and T4 and the associated tuning and coupling capacitors. The PTO is tunable from 4955 kHz to 5455 kHz. The output of the PTO is applied to the cathode of V6. The output of crystal-controlled oscillator Q12 is applied to the grid of V6. The crystal selected to control oscillator Q12 is determined by the settings of the XTALS and BAND switches. The frequency of the crystal selected will always be such that the difference frequency obtained by heterodyning the output of the PTO with the output of oscillator Q12 will be 5645 kHz higher in frequency than the desired signal frequency.

4-4. FIRST MIXER.

The output of premixer V6 is coupled to the first mixer V2 through the permeability-tuned premixer output coils, T3 and T4, and their associated tuning and coupling capacitors. Heterodyning of the premixer output and the RF amplifier output in V2 results in a difference frequency output of 5645

kHz from V2. Gang tuning of the RF coils T1 and T2 and the premixer output coils T3 and T4 is used to maintain a fixed frequency relationship among these variable circuit elements. The output from V2 is applied to the input of a four pole crystal lattice filter with a bandwidth of approximately 8 kHz.

4-5. FIRST IF SYSTEM.

The output of the crystal filter is applied to the gate of Q1, the 5645 kHz IF amplifier. The amplified output of this stage is fed first through the noise blanker, if it is used, and then to grid 1 of V3, the 2nd mixer. Here the 5645 kHz IF signal is mixed with the BFO. In the SSB, CW 1.5, CW .5 or CW .25 modes the output of V3 is the sum of the 5645 kHz IF signal and the BFO or approximately 5695 kHz depending on the setting of the PASSBAND TUNING control. In the AM mode the BFO is off and V3 functions as a buffer amplifier with the output at 5645 kHz. The output of V3 is fed through the MODE switch S2 to the appropriate 8 pole crystal filters. In the AM mode the 5645 kHz IF signal may be fed through a filter or fed directly to stage V4 depending on whether an accessory filter is installed in the AM filter position. In the SSB, CW 1.5, CW .5, and CW .25 modes the signal passes through the 8 pole crystal filter with a center frequency of 5695 kHz. As the frequency of the BFO Q5 is varied by C86, the PASSBAND TUNING control, the desired sideband or portion of the 5645 kHz IF signal is positioned within the passband of the 5695 crystal filter. The output of the crystal filter is then applied to the grid of V4 through the MODE switch, S2. In V4, the 5695 kHz signal is mixed with a 5645 kHz oscillator in the SSB, CW 1.5, CW .5 or CW .25 modes. In the AM mode the 5645 kHz signal is mixed with a 5595 kHz oscillator. The output of V4 is tuned to the difference frequency of 50 kHz by the IF transformer (T7C). The Q of T7C is changed by the position of the MODE switch. In the CW .5 or CW .25 position, the high Q tap is connected to provide additional selectivity.

4-6. SECOND IF SYSTEM AND DETECTORS.

The 50 kHz signal from T7C is coupled to the grid of V5 through the T-Notch filter T8 and its associated circuitry. V5 further amplifies the signal before it reaches the detectors. The signal path from IF transformer T10 is determined by MODE switch S2. In the AM mode, the BFO Q5 is off. Detection is accomplished by diode CR4 and the resulting audio is amplified by Q6. In the SSB, CW 1.5, CW .5 or CW .25 modes the BFO is on. The BFO and IF output both feed the product detector consisting of diodes CR2 and CR3. The MODE switch selects the audio output of either Q6 on AM or the product detector on other modes and applies the audio to the audio amplifier section.

4-7. AGC CIRCUIT.

The output of the 50 kHz IF amplifier V5 also is applied to Q7, the AGC detector. Q7 is biased past cutoff under no-signal conditions. As the amplitude of the signal from V5 is increased, a point is reached where Q7 begins to conduct during a portion of each cycle resulting in a negative DC voltage being developed across resistor R50. Depending on the position of the AGC switch, a combination of capacitors C73, C74, and C76 will be charged by this DC voltage. The release time of the AGC is determined by this capacitor combination and R50. The negative-going AGC voltage is applied to various filtering and delay networks and then to the grids of V1, V3 and V5. Counterclockwise rotation of the RF GAIN control increases the negative bias on the AGC controlled stages, limiting their gain. Isolation of the mute line from ground also allows the AGC line to swing to approximately 40 Volts negative, cutting off the three stages and muting the receiver.

4-8. S METER.

The S Meter is connected across a bridge circuit which has the plate of V5 as one arm of the bridge, and the plates of V2 and V4 as the other arm of the bridge. Increasing signal strength results in the application of AVC voltage to the grid of V5 causing the plate current to decrease thus unbalancing the bridge and causing the S Meter to deflect up

scale. Potentiometers R32 and R33 are used to set the bridge balance point, determining the zero adjustment of the S Meter. The current characteristics of the plate circuits of V2 and V4 are such that line voltage variation does not affect the zero setting of the bridge circuit. The sensitivity of the S Meter is determined by the setting of potentiometer R36, which is in series with the S Meter.

4-9. AUDIO AMPLIFIER.

The audio amplifier consists of a direct coupled, Class A, transformer output audio amplifier consisting of Q9, Q10, Q11, T13 and other associated parts. T13 has two secondary windings; one to match a speaker or headphone output and a high impedance winding for antivoice voltage. The audio gain is varied by R72, the AF GAIN control, at the input of Q9. Negative feedback is used to reduce distortion and increase stability of the amplifier.

4-10. POWER SUPPLY.

The power supply consists of transformer T14 and the associated circuitry. CR8, CR9, C163, R114, and C164 form a full-wave, center-tapped configuration to supply 150 Volts DC. CR10, CR11 and C167 form another full-wave rectifier to provide 12 Volts DC for the solid state stages. Q2, C166 and R116 form a filter to reduce the ripple on the 12 Volt supply. Negative bias voltage is obtained from half-wave rectifier CR7 and C162.

4-11. CRYSTAL CALIBRATOR.

When the FUNCTION switch is turned to the calibrate position, a ground is supplied to the calibrator circuitry. Q14 is a crystal controlled oscillator at 100 kHz. The output from Q14 is fed to CR16 and Q15 which shape the waveform to trigger the first J-K flip-flop in U1. The 100 kHz is applied to the clock input causing the flip-flop to change state once every cycle of the input, thus dividing by two. The output of the first flip-flop is applied to the clock input of the second J-K flip-flop which again divides by two. The output of this flip-flop is a 25 kHz square wave which is applied to the antenna of the receiver through the coupling network.

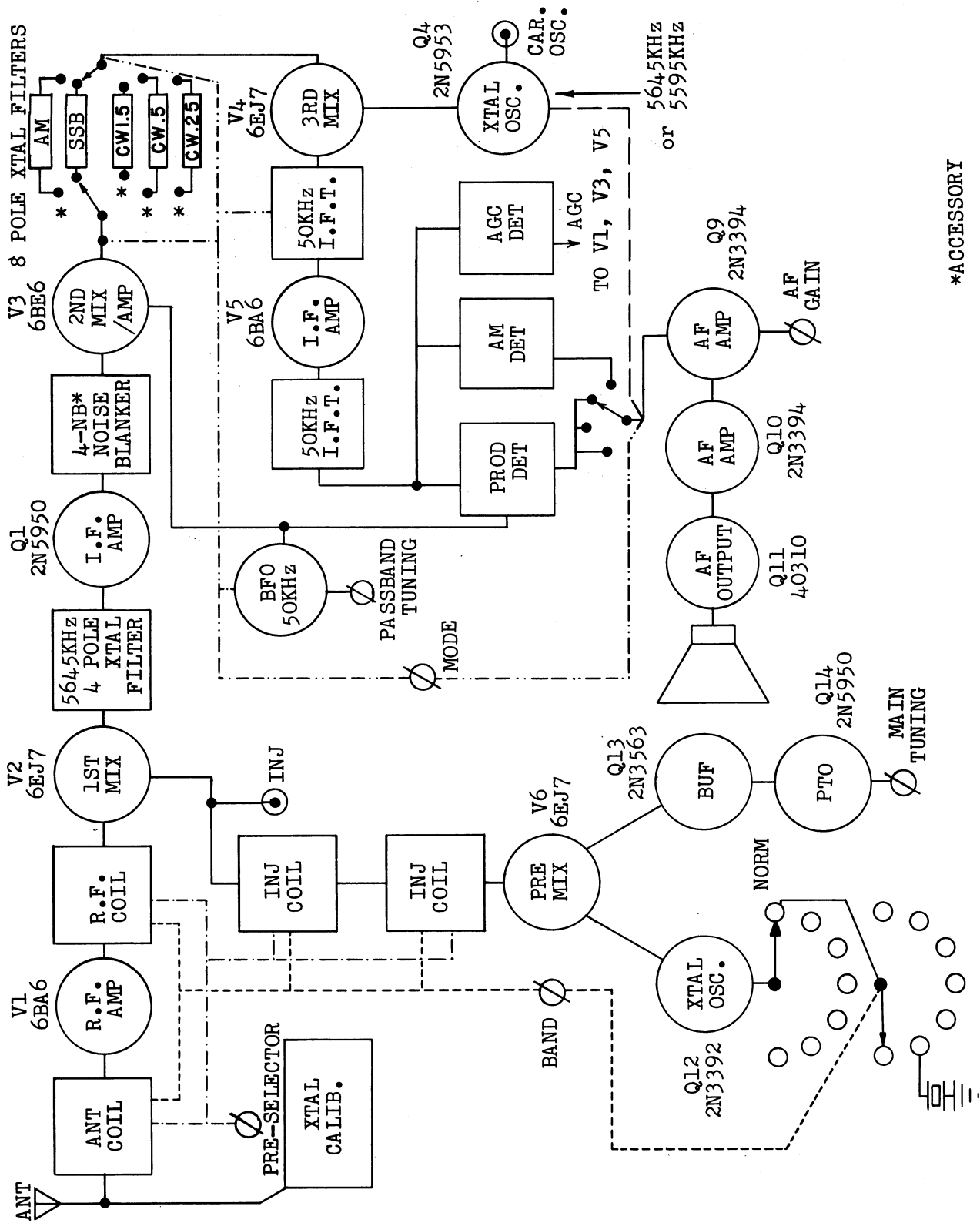

*ACCESSORY

Figure 4-1. Block Diagram

NOTES

CHAPTER V

MAINTENANCE

5-1. SERVICE DATA.

We will check and align your receiver at the factory for a nominal fee if it has not been tampered with. Transportation charges are extra. Any necessary repairs will be made on a time and material basis. Please write or call the factory for authorization before returning your receiver for alignment or service. Address your request for authorization to:

R. L. Drake Company
540 Richard Street
Miamisburg, Ohio 45342
ATTN: Customer Service Department
Telephone: (Area Code 513) 866-3211
Code-A-Phone Service after
1630 Hours E.S.T.

5-2. MAINTENANCE.

WARNING

Disconnect the R-4C from the power source before removing the covers. High voltage which is present at several points can cause a lethal electrical shock.

Careful consideration has been given in the design of the R-4C to keeping maintenance problems to a minimum. However, it is quite possible that some problem will arise which cannot be solved by tube substitution. If this occurs, we suggest that you either return the unit to your dealer, or write direct to our Service Department, describing your problem in detail. Include full information concerning external connections, control settings, tubes substituted, serial number, etc.

5-3. COVER REMOVAL.

- a. Remove the three top screws on each side of the R-4C.
- b. Remove top cover by first pulling up on the rear and then on the front of the cabinet.

- c. Remove the six bottom screws from the sides of the R-4C.
- d. Lift the R-4C chassis out of the bottom cover.

5-4. TEST EQUIPMENT REQUIRED.

- a. Stable RF signal generator with calibrated output attenuator and a frequency range of 50 kHz to 30 MHz.
- b. Frequency counter or oscillator accurate to within 50 Hz at 5.645 MHz.
- c. VTVM with 11 megohm input impedance.
- d. A 12.6 MHz accessory crystal for operation of the 1.5 through 2.0 MHz segment, if this band is to be aligned.
- e. An accessory crystal for reception of the WWV standard frequency transmission that is most reliably received in your area.
- f. A scale with 1/32 inch divisions.
- g. Two 10 K 1/2 W resistors.

5-5. TROUBLESHOOTING.

The R-4C has been designed so that tubes can be replaced without need for realignment. The best method of finding defective tubes is by direct substitution. Do not rely too heavily on a tube checker.

The voltage and resistance charts, tables 5-1 and 5-2 should be valuable in isolating minor problems. However, no attempt should be made to service the R-4C unless you are thoroughly familiar with electronic circuitry and servicing technique. Care should be taken not to disturb the lead dress in the R-4C. It is critical in several circuits.

5-6. ALIGNMENT INSTRUCTIONS.

Turn receiver on and adjust for SSB reception.

5-7. 50 kHz BFO AND IF ALIGNMENT.

- a. Apply signal of exactly 50.000 kHz to pin 2 of V4 (6EJ7). (Maximum frequency error of 25 Hz.)
- b. Set PASSBAND control to exact center of range (12 o'clock position).
- c. Set MODE switch to CW .5 or CW .25 position.
- d. Tune T11 for zero beat.
- e. Tune T7C and T10 for maximum negative voltage on AGC line or for maximum S meter reading.
- f. Disconnect 50 kHz signal from V4.

5-8. 5645 OSCILLATOR ADJUSTMENT.

- a. Connect signal generator or oscillator to pin 2 of V2 (6EJ7).
- b. Set generator frequency with counter to exactly 5645.000 kHz. Accuracy should be within 50 Hz.
- c. Adjust C59 (top trimmer on second mixer oscillator board on top of chassis) for zero beat.
- d. Disconnect generator from V2.

5-9. FILTER MATCH ALIGNMENT.

- a. Tune in crystal calibrator signal on 80 M band. Set AGC switch to M.
- b. Turn MODE Switch to AM mode.
- c. Adjust PTO upwards in frequency until calibrator level drops 20 dB (or 4 S units).
- d. Adjust T5 for maximum negative AGC voltage or maximum S meter reading.
- e. Set MODE Switch to SSB and PASSBAND TUNING to center.
- f. Tune PTO until calibrator signal is zero beat.
- g. Turn PASSBAND TUNING control counterclockwise toward LSB until S meter drops 25 dB (or 5 S units).
- h. Tune C42 and T6 for maximum S meter reading or maximum negative AGC voltage. If 2 peaks are observed on C42, choose the one at minimum capacitance.

5-10. NOTCH FILTER ADJUSTMENT.

- a. Turn NOTCH control until the slug in the notch coil is the greatest distance out of the coil (to-

ward the front panel). The pointer on the knob should be at the nine o'clock position. If it isn't, loosen the knob setscrew and position the knob at the nine o'clock setting. Tighten set screw. Turn NOTCH control until it goes into the detent (slug completely into coil). The knob should be at the "OFF" position.

- b. Tune in signal generator on any band, SSB Mode. Set level for approximately 30 dB over S9.
- c. Set PASSBAND control to exact center (12 o'clock).
- d. Tune PTO for zero beat.
- e. Adjust NOTCH control for null. The knob should point very close to the 12 o'clock position. If it doesn't, adjust the slug in the notch coil until the null occurs at 12 o'clock. Be sure steps c and d have been performed before making any adjustment.
- f. Keep the NOTCH control adjusted for deepest null, and adjust R39 (the red potentiometer located on the longest PC board) for deepest notch.

5-11. 5595 OSCILLATOR ADJUSTMENT.

This oscillator affects only the AM mode.

- a. Tune in signal generator on any band in the SSB Mode.
- b. Set PASSBAND control at exact center.
- c. Tune PTO for zero beat.
- d. Adjust NOTCH control for deepest null.
- e. Switch MODE switch to AM being careful not to upset other control settings.
- f. Adjust C60 (lower trimmer on second mixer crystal oscillator board on top of chassis) for deepest notch.

5-12. ANTENNA, RF, AND INJECTION ALIGNMENT.

- a. Turn off the receiver. Refer to figure 5-2 and determine the location of S1D and S1E (these are the third and fourth bandswitch wafers, counting from the front of the receiver). Locate these switch wafers in the receiver. Each of these switch wafers has two rotor contacts colored

green. Connect a 10,000 Ohm resistor from the more easily accessible of the two rotor contacts on S1D to ground. From the corresponding rotor contact of S1E, connect a 10,000 Ohm resistor to B+. The easiest point to make this connection is the red and white striped wire on the terminal strip near S1E.

- b. Disconnect the antenna from the R-4C, and connect a 47 Ohm resistor from the center of the antenna jack to ground.
- c. Plug the 12.6 MHz crystal into one of the accessory crystal sockets.
- d. Set the receiver right side up on the bench and turn the PRESELECTOR knob as far clockwise as possible. Carefully measure the distance from the top of the slug of T1 to the top of the white liner projecting through the hole in the top of T1. The distance was set at the factory to exactly 9/16 inch. Check the measurement carefully before altering the position of the slug. The distance that the slug projects must be exactly 9/16 inch. Check the setting of the slugs in T2, T3, and T4. All must have the same 9/16 inch projection.
- e. Turn the receiver on, set the BAND switch to 28.5, the FUNCTION switch to CAL, and tune in the calibrator signal at 28.7 MHz. Allow the receiver to warm up for a few minutes.
- f. Adjust the PRESELECTOR knob so the slugs in T1 through T4 project exactly 15/32 inch above the white liners.
- g. Refer to figure 5-1. Adjust the four trimmers marked 28.7 for maximum S Meter reading. If the calibrator signal is insufficient to produce an adequate S Meter indication, remove the 47 Ohm resistor from the antenna input, and connect the signal generator to the antenna input. Set the R-4C FUNCTION switch to EXT. MUTE, adjust the signal generator to 28.7 MHz, and set the generator output level to cause an S Meter indication of approximately S-7. Adjust the four trimmers marked 28.7 for maximum S Meter indication.
- h. Repeat steps f and g for each band, using the settings given below:

<u>BAND</u>	<u>SLUG HEIGHT</u>	<u>FREQUENCY</u>
21.0	7/16 inch	21.3 MHz
14.0	11/32 inch	14.3 Mhz
7.0	3/16 inch	7.3 MHz
3.5	Flush with White sleeve	3.8 MHz
1.5	Flush with White sleeve	1.9 MHz

NOTE: For the 1.5 band, the XTALS switch must be set to the position corresponding to the number of the socket into which the 12.6 MHz crystal was inserted.

- i. Turn off the R-4C, and remove the alignment resistors.

5-13. S METER ADJUSTMENT.

- a. Tune in a 1 microvolt signal from the signal generator on the 40 meter band. Peak PRESELECTOR and PASSBAND for maximum strength.
- b. Set S METER ZERO control on rear panel to mid-range.
- c. Adjust R33 for S-3 reading.
- d. Remove signal and adjust the bias potentiometer R55 for S-1 reading.
- e. Apply a 30,000 μ V signal and adjust the S METER sensitivity adjustment R36 for 60 dB over S-9.
- f. Repeat steps a. through e. several times if necessary.

5-14. CRYSTAL CALIBRATOR ADJUSTMENT.

- a. Connect the antenna to the R-4C, and set the receiver controls for AM reception of WWV. Tune in WWV.
- b. Refer to figure 5-1 and determine the location of C174.
- c. Insert a shorted plug in the MUTE jack, and set the FUNCTION switch to CAL.
- d. Adjust the audio gain until you can hear the beat note between WWV and the calibration signal.
- e. Adjust C174 for zero beat with the WWV signal.

Table 5-1. Resistance Chart

REF DES	Type	MEASURED AT PIN								
		1	2	3	4	5	6	7	8	9
V1	6BA6	4 M	0	0	0.01	5.5 K	9 K	0	—	—
V2	6EJ7	470	100 K	470	0	.01	0	6.5 K	12 K	0
V3	6BE6	5.0 M	0	0	0.01	5.5 K	16 K	12 K	—	—
V4	6EJ7	470	1 M	470	0	.01	0	6.5 K	42 K	0
V5	6BA6	10 M	0	0	0.01	5.5 K	9 K	0	—	—
V6	6EJ7	470	680 K	470	0	.01	0	5 K	6 K	0
Q1	2N5950	D:180	G:1 K†	S:68	—	—	—	—	—	—

NOTE: All measurements were made with reference to chassis ground with an 11 megohm VTVM. Both GAIN controls fully clockwise. FUNCTION: off. MODE: SSB. AGC: slow. Antenna: disconnected. BAND: 3.5. PRESELECTOR peaked on noise at 3.5. XTALS: NORM. Shorted plug in MUTE jack. AC line cord disconnected. Readings: ± 10%.

†With lead to xtal filter disconnected.

Table 5-2. Voltage Chart

REF DES	Type	MEASURED AT PIN								
		1	2	3	4	5	6	7	8	9
V1	6BA6	-1.0- -2.0	0	0	6.3*	140	55	0	—	—
V2	6EJ7	2.3	0	2.3	0	6.3*	0	130	120	0
V3	6BE6	-.5- -1.5	0	0	6.3*	125	40	-1.0	—	—
V4	6EJ7	1.8	0	1.8	0	6.3*	0	130	90	0
V5	6BA6	-1.0- -2.0	0	0	6.3*	125	120	0	—	—
V6	6EJ7	2.0	-.5- -3.0	2.0	0	6.3*	0	145	85	0
Q1	2N5950	D:13.0	G:0	S:.75	—	—	—	—	—	—
Q2	EP487	C:16.0	B:16.2	E:15.5	—	—	—	—	—	—
Q11	40310	C:14.5	B:1.1	E:.45	—	—	—	—	—	—

NOTE: All measurements were made with reference to chassis ground with an 11 megohm VTVM. Both GAIN controls fully clockwise. FUNCTION: on. MODE: SSB. AGC: slow. Antenna: disconnected. BAND: 3.5. PRESELECTOR peaked on noise at 3.5. XTALS: NORM. Shorted plug in MUTE jack. Line voltage: 117 Volts AC. Readings: ± 10%.

*: AC Voltage.

Table 5-3. Tube and Semiconductor Complement

REF DES	TYPE	FUNCTION
V1	6BA6	RF Amplifier
V2	6EJ7	First Mixer
V3	6BE6	Second Mixer
V4	6EJ7	Third Mixer
V5	6BA6	Last IF Amplifier
V6	6EJ7	Premixer
Q1	2N5950	First IF Amplifier
Q2	EP487	Power Supply Filter
Q3	2N5950	Source Follower
Q4	2N5953	Crystal Oscillator
Q5	2N3394	BFO
Q6	2N3394	AM Detector Amplifier
Q7	2N3877	AGC
Q8	2N5950	PTO
Q9	2N3394	Audio Amplifier
Q10	2N3394	Audio Amplifier
Q11	40310	Audio Output
Q12	2N3392	Crystal Oscillator
Q13	2N3563	PTO Buffer
Q14	2N5950	100 kHz Calibration Oscillator
Q15	2N3394	Calibrator Shaper
U1	SN7473	Calibrator Divider
CR1	1N4148	AGC
CR2	1N270	Product Detector
CR3	1N270	Product Detector
CR4	1N270	AM Detector
CR5	1N270	Premixer Clamp
CR6	1N714	Voltage Regulator
CR7-11	B5G5	Power Supply
CR12	1N4148	AGC
CR13	1N4148	AGC
CR14	1N5240A	Voltage Regulator
CR15	1N4148	Premixer Keying
CR16	1N270	Calibrator Shaping
CR17	1N714	Voltage Regulator
CR18	B5G5	Power Supply
CR19	B5G5	Power Supply
CR20	1N270	Third Mixer Injection Clipper
CR21	1N270	Third Mixer Injection Clipper
CR22	1N4148	AGC

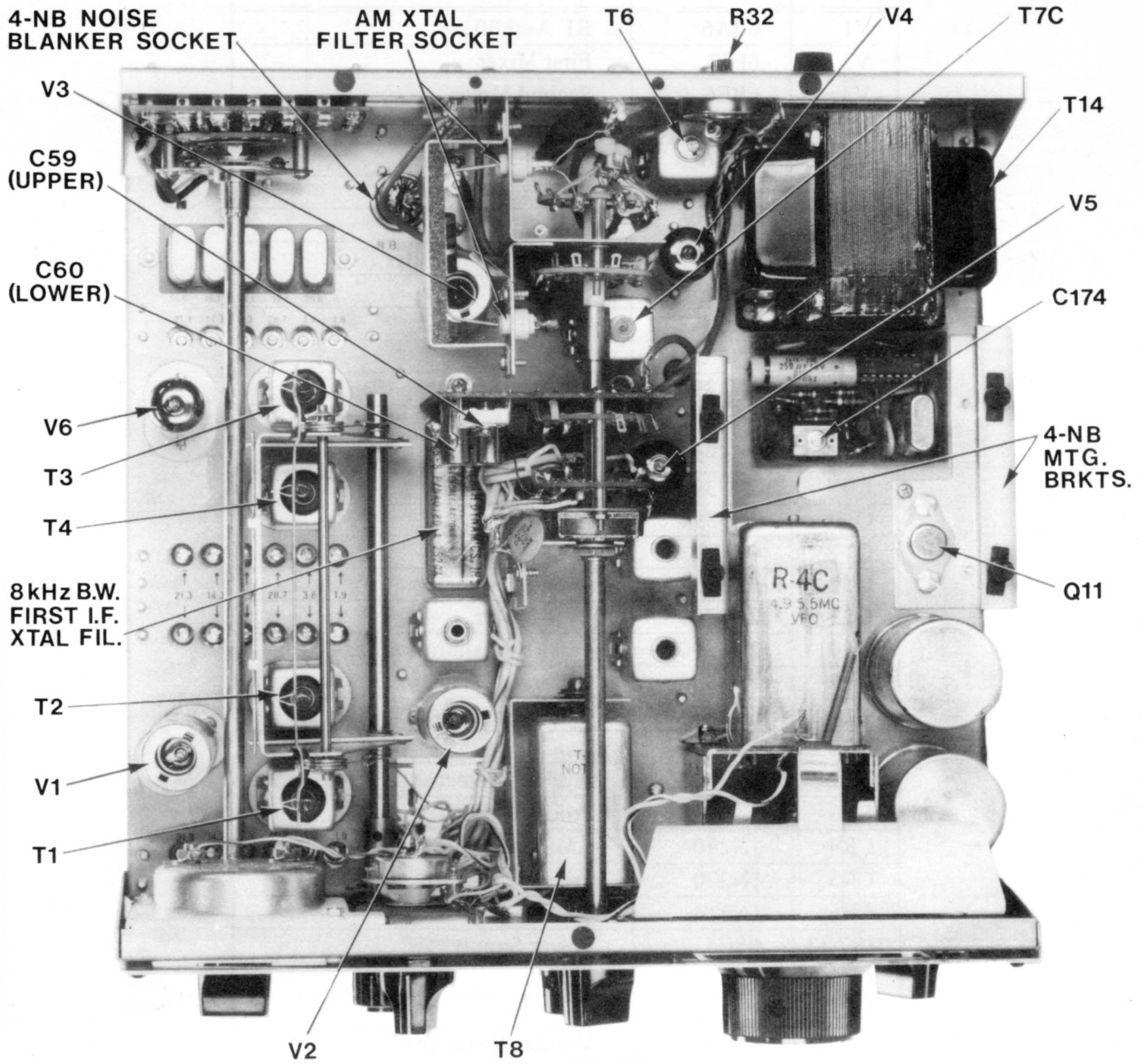

Figure 5-1. Alignment Locations, Top View

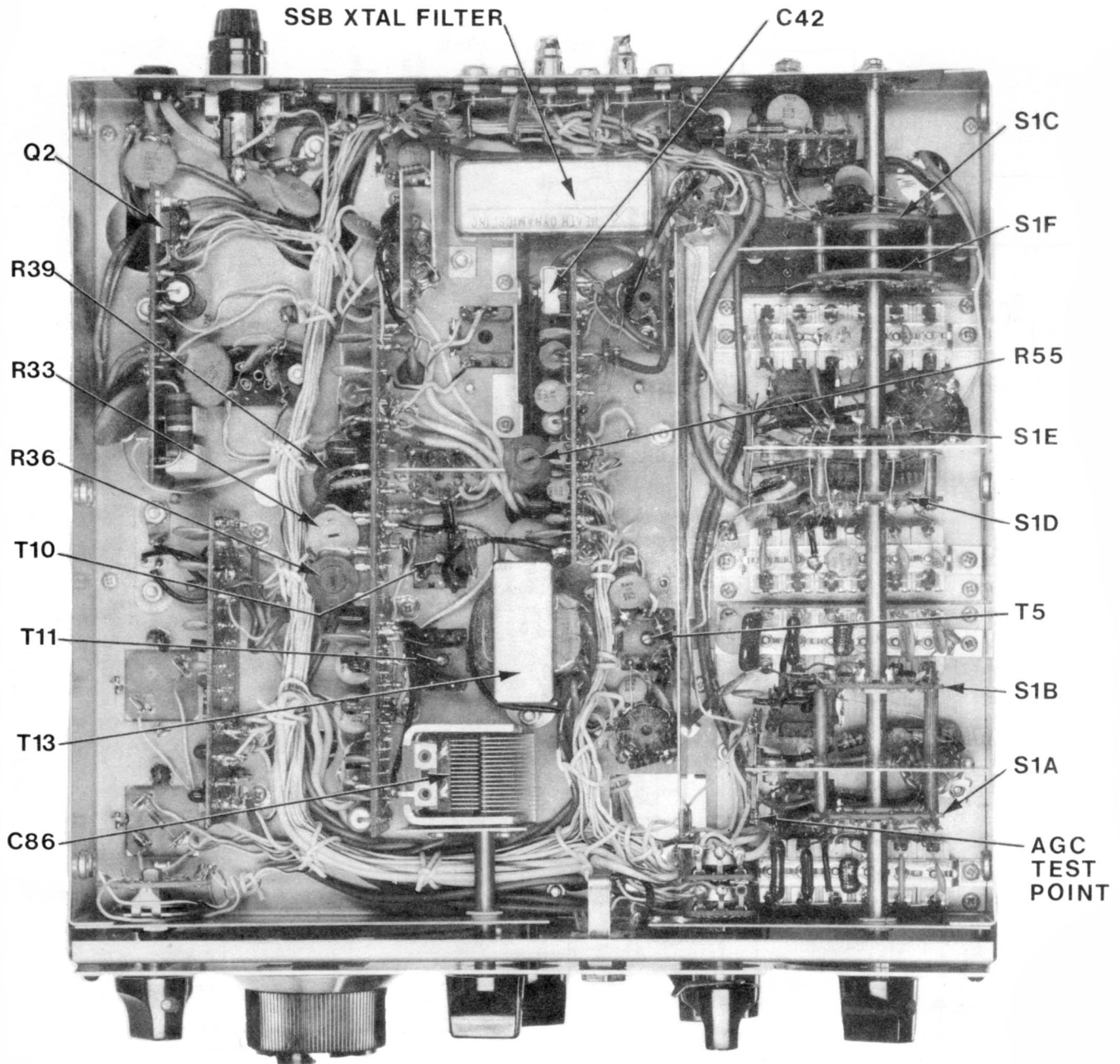
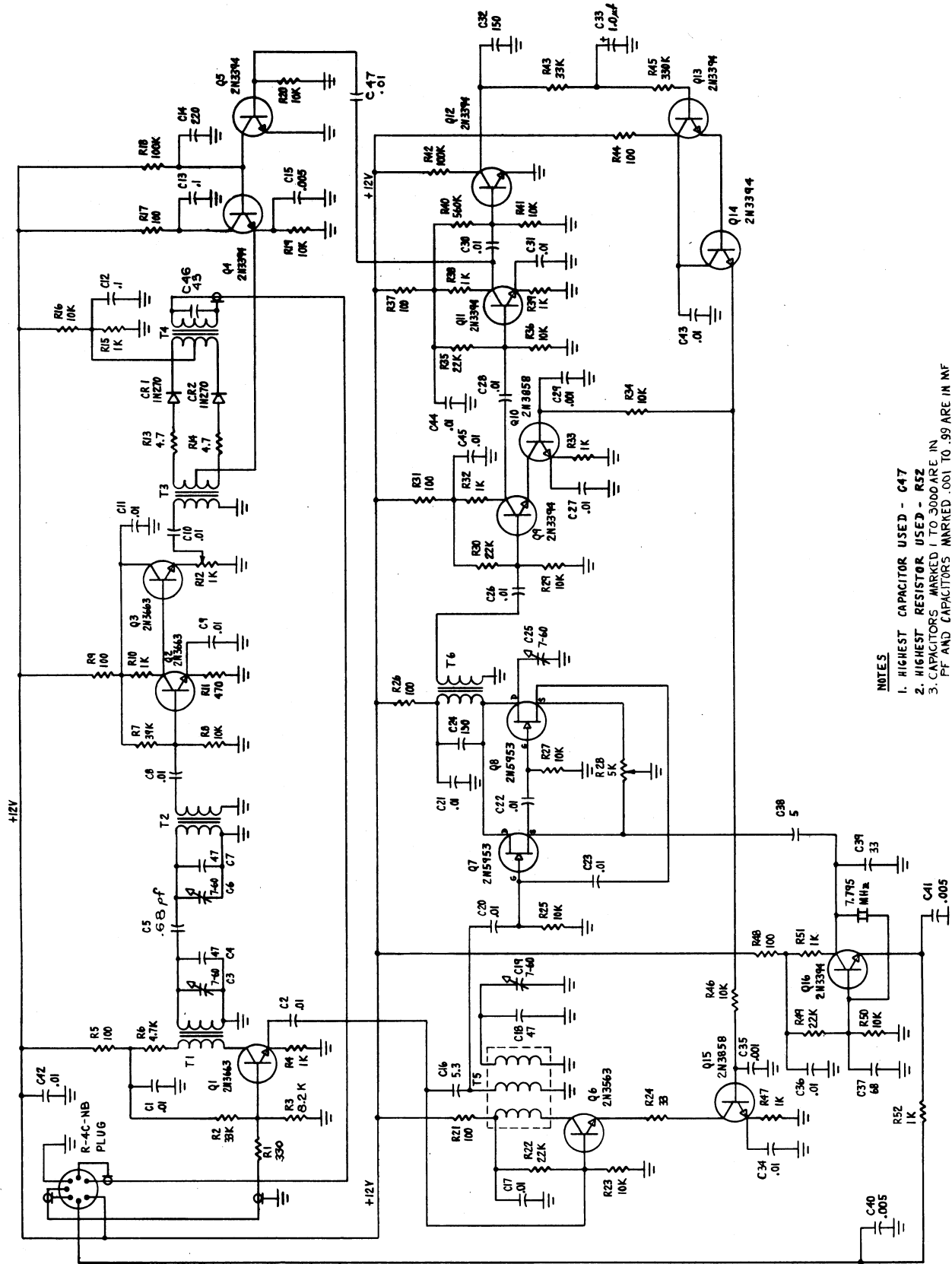
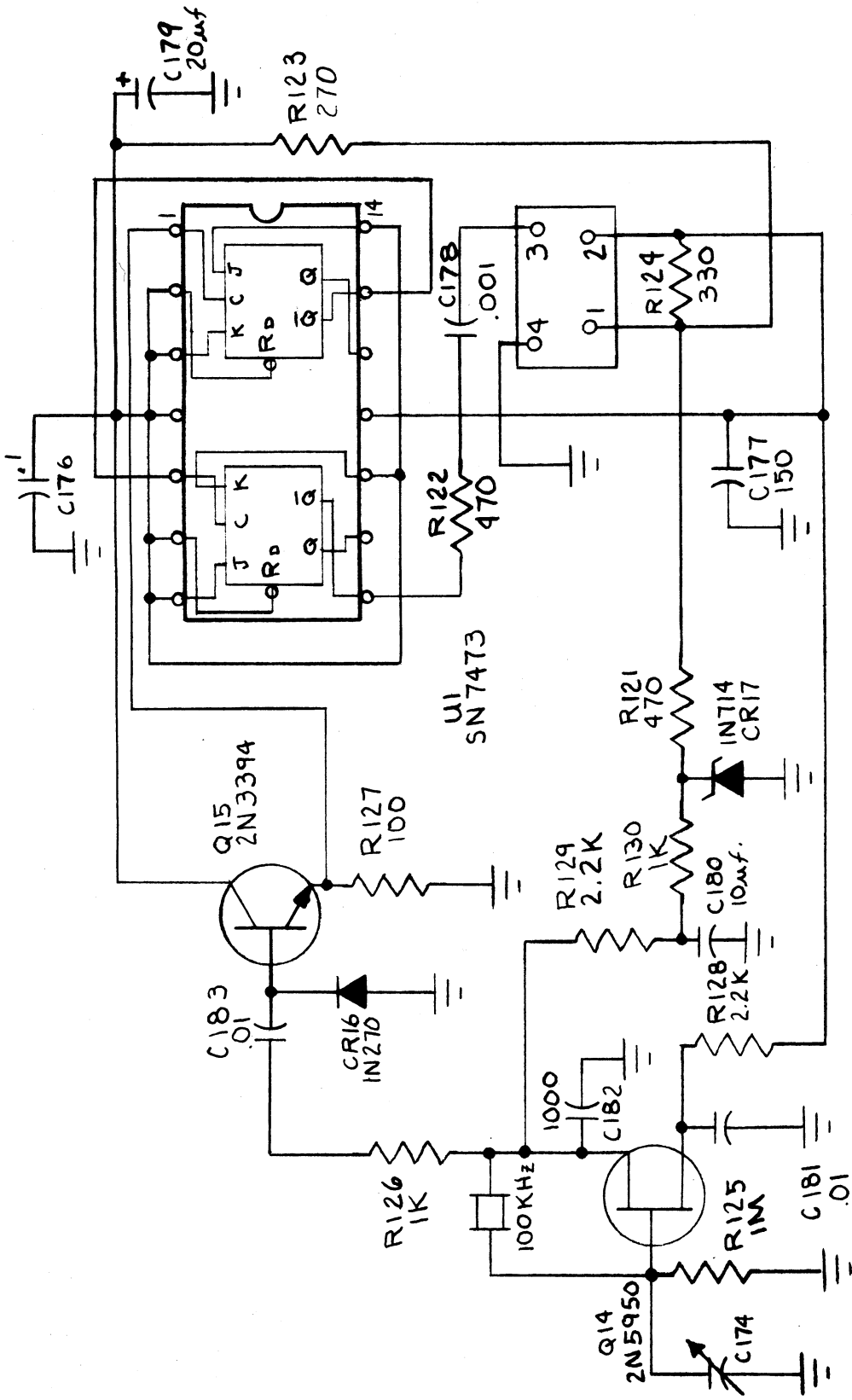

Figure 5-2. Alignment Locations, Bottom View



- NOTES**
1. HIGHEST CAPACITOR USED - C47
 2. HIGHEST RESISTOR USED - R52
 3. CAPACITORS MARKED 1 TO 3000 ARE IN PF AND CAPACITORS MARKED .001 TO .99 ARE IN MF

Model 4-NB Noise Blanker



RCC4 CRYSTAL CALIBRATOR
PART OF R-4C

Crystal Calibrator

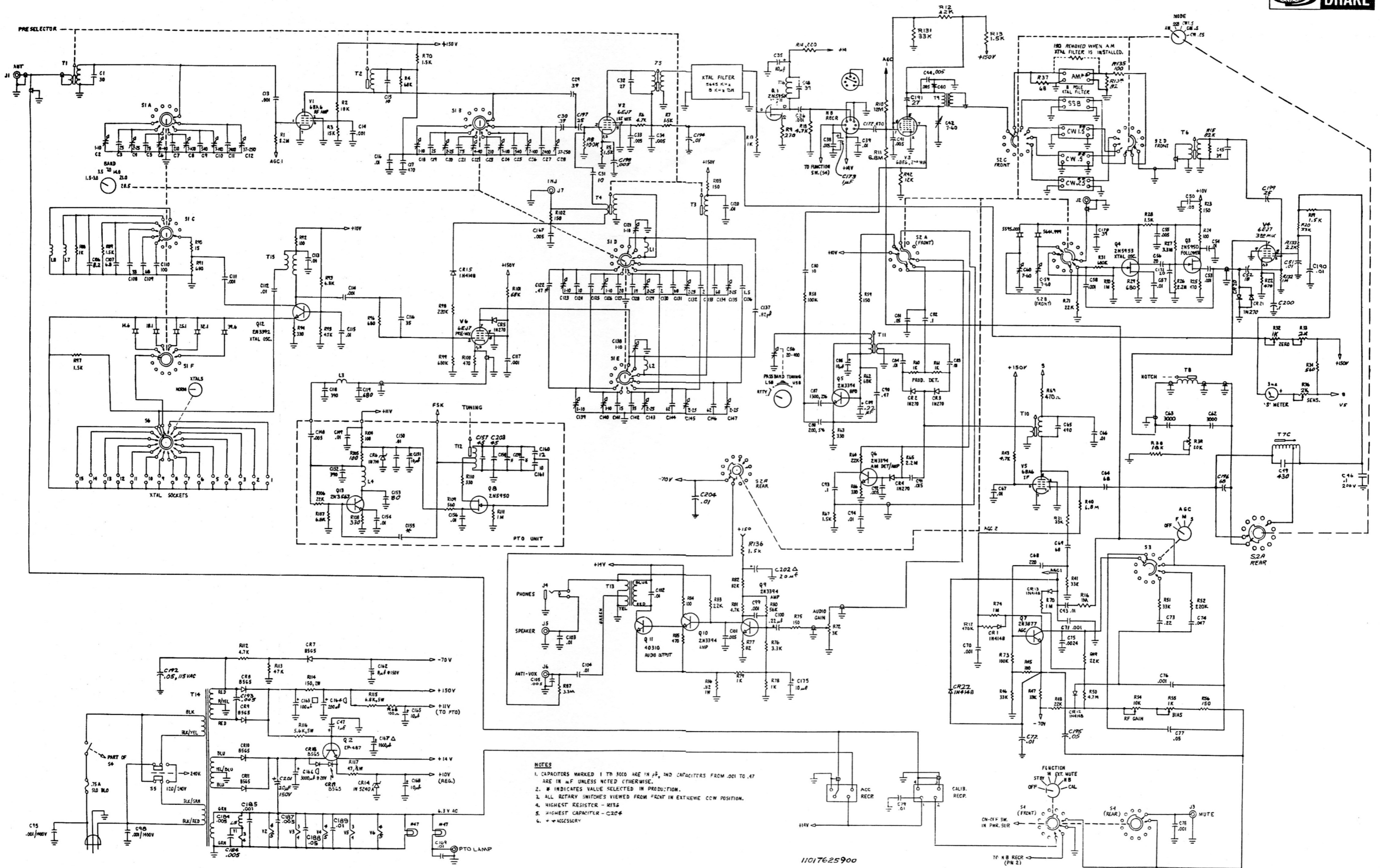

Figure 5-3. Schematic Diagram



DRAKE AMATEUR PRODUCTS

- R-4C** Receiver, covers the 160 meter through 10 meter amateur bands and up to fifteen additional 500 kHz ranges. It has 8-pole crystal filter selectivity with passband tuning and transceives with the T-4XC with excellent sensitivity.
- T-4XC** Transmitter, covers the 160 through 10 meter amateur bands and most other frequencies between 1.5 and 30 MHz. It has 8-pole crystal filters for sideband selection. It may be used to transceive with the R-4C.
- TR-4C** Transceiver, 300 Watt high frequency single-sideband unit covers the 80 meter through 10 meter amateur bands. Includes AM and CW modes, a linear, permeability-tuned VFO and two 8-pole crystal lattice filters.
- L-4B** Linear Amplifier, built for continuous duty at full capacity. 2000 Watts PEP on SSB. 1000 Watts on AM, CW and RTTY. Covers the 80 meter through 10 meter bands.
- SPR-4** An all solid-state communications receiver which can be programmed with accessory crystals to cover 150 kHz to 30 MHz. The SPR-4 receives AM, CW, SSB, (upper and lower) and may be powered from 120 VAC, 240 VAC, and 12 VDC.
- FS-4** Frequency Synthesizer, built for use with R-4 series, SPR-4, 2-C receivers, and T-4X series transmitters.
- MN-4** Antenna Matching Network, matches 50 Ohm transmitter output to coax antenna feedline with VSWR up to 5:1. An integral Wattmeter reads forward power in Watts and VSWR directly. 200 Watts continuous duty output.
- MN-2000** Antenna Matching Network. Same as MN-4 except: 1000 Watts continuous duty output (2000 Watts PEP) and 3 antenna connectors switch-selectable from front panel.
- W-4** Wattmeter, reads forward and reflected power directly in Watts (VSWR from nomograph). Range: 200 and 2000 Watts full scale, 1.8 to 54 MHz.
- WV-4** Wattmeter, reads forward and reflected power directly in Watts (VSWR from nomograph). Range: 100 and 1000 Watts full scale, 20 to 200 MHz.
- TR-33C** Transceiver, 2 meter VHF-FM, portable. Twelve channels, self-contained batteries and attached microphone.
- RCS-4** Remote Coax Switch, provides remote selection of up to five antennas, using only one main feedline. Allows grounding of unused antennas. Motor driven switches controlled from station located console.
- SSR-1** General Coverage Receiver, 0.5-30 MHz continuous. All solid state.

For information on any of our products, please feel free to write our Sales Department, 540 Richard Street, Miamisburg, Ohio 45342 or call direct, 513-866-2421.



