

Owner's Guide

MODEL S-107, MARK II

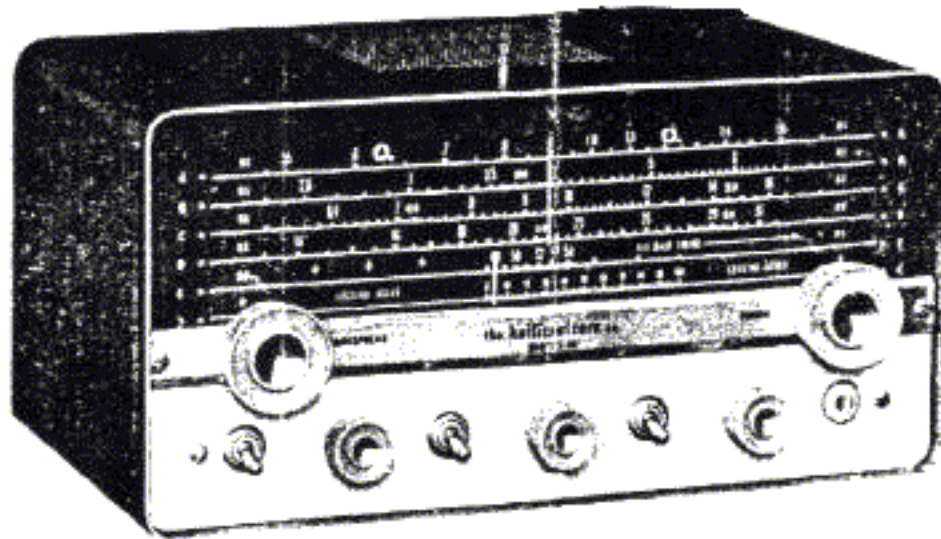

Figure 1. Hallicrafters Model S-107, Mark II

GENERAL DESCRIPTION

Your new Hallicrafters Model S-107 tunes from 540 kilocycles to 31 MC and 48 to 54.5 megacycles to bring you the finest in world-wide radio reception. You'll hear foreign and domestic shortwave broadcasts, amateurs, police, aircraft, ships, and countless other exciting distant stations... as well as all your favorite programs on the standard broadcast band. The receiver employs a superheterodyne circuit which consists of 7 tubes and a rectifier, and provides for the reception of AM (voice) and CW (code) signals throughout its entire tuning range. Special features in this receiver include an electrical bandspread dial for fine tuning of the amateur and shortwave bands, a sensitivity control, provisions for use with an external amplifier, a powerful built-in Alnico V permanent magnet speaker, provisions for headphone operation, and a receive-standby switch on the front panel that permits you to silence the receiver without turning it off. Your receiver has an unusually high degree of sensitivity necessary to receive weak and distant stations. Careless operation may result in excess noise or background hiss. These undesirable effects can be held to a minimum by careful adjustment of the tuning controls as well as the proper selection and arrangement of the antenna.

POWER SOURCE

The S-107 receiver is designed to operate on 105 to 125 volt 50/60 cycle, AC current. The power consumption of the S-107 is 50 watts.

CAUTION: If in doubt about your power source, contact your local power company prior to inserting the power cord into an AC power outlet. Plugging the power cord into the wrong power source can cause extensive damage to the receiver; requiring costly repairs.

HEADPHONES

A standard two-conductor headphone jack, marked "PHONES" is located on the front panel of the receiver and is wired so that the speaker is automatically disabled when headphones are plugged into the jack. Any commercial low impedance headphones ranging from 50 to 1000 ohms may be used.

the hallicrafters co.

MANUFACTURERS OF ELECTRONIC EQUIPMENT, CHICAGO 24, U. S. A.

ANTENNAS

The receiver is designed to operate from either a single-wire antenna, or a half-wave doublet or other tuned antenna. Antenna connections are made to a three-terminal strip at the rear of the receiver marked "A1", "A2", and "G".

Single-Wire Antenna

The simplest antenna and one which will provide satisfactory performance throughout the entire tuning range is a conventional single-wire antenna. In most localities, satisfactory results can be obtained with just the 15-foot antenna wire included with the receiver. It is simply necessary to attach one end of this wire to terminal "A1", connect the jumper link between "A2" and "G", and then run the wire about the room in any convenient manner. (See Fig. 2). If the receiver is operated in a steel constructed building or where receiving conditions are exceptionally poor, an outside antenna 50 to 100 feet long may be necessary. In some locations, reception may be improved by connecting a ground wire (ordinary copper wire) from terminal "G" to a cold water pipe or outside ground. While the use of an outside ground rod installed in accordance with Insurance Underwriter's Laboratories requirements is adequate protection against lightning, we strongly recommend an additional connection to the nearest cold water pipe to eliminate any shock hazard.

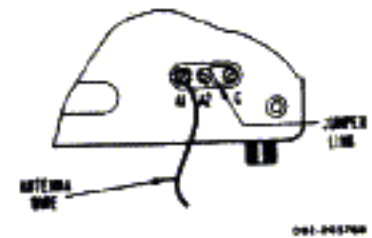

Figure 2. Single Wire Antenna

Half-Wave Doublet Antenna

For top performance, especially on the shortwave and amateur bands, the use of half-wave doublet or other type of antenna employing a 52 to 600 ohm transmission line is recommended. A typical doublet antenna installation is shown in Fig. 3. The doublet antenna should be cut to the proper length for the most used frequency or band of frequencies. The overall length in feet of a doublet antenna is determined by the following formula:

$$\text{Length in feet} = \frac{468}{\text{Frequency in megacycles}}$$

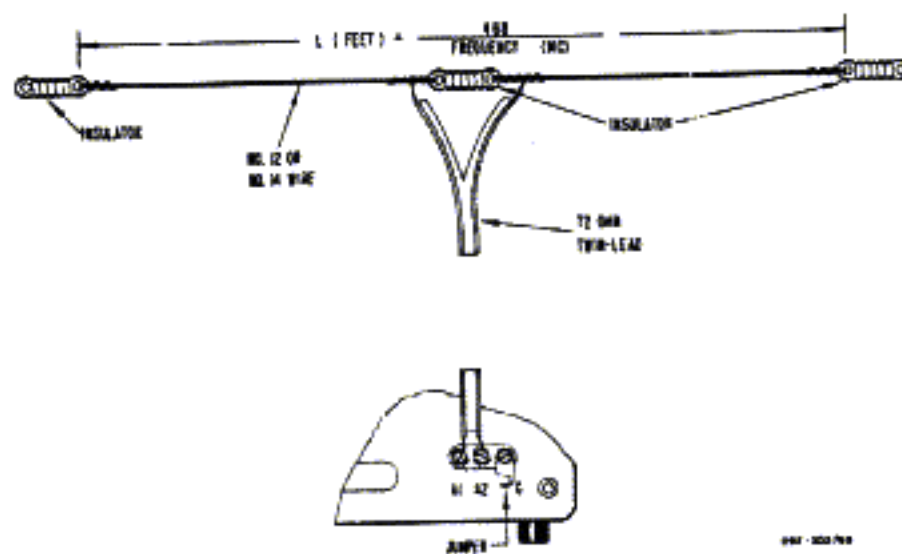

Figure 3. Doublet Antenna Using Twin-Lead Transmission Line

wire type. This is accomplished by connecting the two transmission line leads together and connecting them to terminal "A1". The jumper link in this case should be connected between terminals "A2" and "G".

TUNING DIAL

The top dial scale is the standard broadcast band. To convert the readings on this band to kilocycles simply add one zero. For example: 70 on the dial is 700 kilocycles. The shortwave bands are marked B, C, and D. The readings on these bands are in megacycles. The standard broadcast band is marked with a "CD" emblem and a dot at 640 and 1240 kilocycles to indicate the two official civil defense frequencies. In a civil defense emergency, tune either of these two frequencies for official civil defense news, instructions, and information.

For maximum signal pickup, the doublet antenna should be erected with its length at right angles to the desired station. When a transmission line such as "twin-lead" or a twisted pair is used, the transmission line connects to terminals "A1" and "A2", and the jumper link between "A2" and "G" is disconnected. The doublet antenna provides optimum performance only at the frequency for which it is cut. Therefore, it may be desirable for reception on frequencies remote from the antenna frequency to utilize the antenna as a single

RECEIVE-STANDBY SWITCH

This switch is normally set at "Receive". When set at "Standby", the receiver is silenced but the tubes remain at operating temperature for instant use. To resume reception at any time, simply return the switch to the "Receive" position.

AM-CW SWITCH

Set this switch at "AM" to listen to voice or musical broadcasts. Set it at "CW" only if you wish to hear code signals.

BAND SELECTOR CONTROL

Set this control for the band you wish to tune. The five positions of this control correspond to the band numbers at the left side of the dial.

BAND	FREQUENCY RANGE
A	540 KC - 1630 KC
B	2.5 MC - 6.3 MC
C	6.3 MC - 18 MC
D	14 MC - 31 MC
E	48 MC - 54.5 MC

OFF-VOLUME CONTROL

Turn this control clockwise to turn the receiver on and to increase volume. Allow about one minute for the tubes to warm up. To turn the receiver off, simply rotate the Off-Volume control fully counterclockwise until a click is heard.

SENSITIVITY CONTROL

Normally set the Sensitivity control fully clockwise for maximum sensitivity. If hiss or background noise are excessive, or if strong signals cause distortion or block the receiver, reduce the sensitivity slightly by turning the control counterclockwise. If after reducing the sensitivity more volume is needed, advance the Volume control.

NOISE LIMITER SWITCH

Normally set the Noise Limiter switch at "Off". If severe electrical disturbances, ignition noise, or other types of pulse-type noise interfere with reception, set the switch at "Noise Limiter" (up) to place the automatic noise limiter circuit in operation.

TUNING OF BANDS A,B,C,D

Set the Bandsread dial pointer at "100" and carefully tune in the desired station with the Tuning control. After the station has been accurately tuned in, reset the Volume control for the desired volume level. When trying to locate weak distant stations, it is suggested that the Volume control be initially set near maximum and then readjusted for the desired level after the station has been tuned in. If the signal is too strong, always reduce it by means of the Volume control, not by using the Tuning control. For CW (code) reception, adjust the Tuning control for the desired pitch when tuning in the station.

TUNING OF BAND E

Set the Tuning dial pointer at the right hand index marks on the dial and tune in the desired station with the Bandsread control. For CW (code) reception, adjust the Bandsread control for the desired pitch when tuning in the station.

IMPORTANT: The dial readings on Bands A, B, C, and D will be correct only if the Bandsread dial pointer is set at "100". The readings on Band E will be correct only if the Tuning dial pointer is set at the right-hand index marks.

BANDSPREAD CONTROL

The Bandsread control is a fine tuning adjustment which permits you to accurately tune in stations on bands A, B, C and D. It may be used in two different ways. The first method of tuning is used when it is desired to tune in a single signal with precision accuracy. The Bandsread dial pointer is set at about "95", then the signal is located with the Tuning control, and finally the signal is accurately tuned in by "rocking" the Bandsread control (turning it a few degrees to the left and right) until the signal is loudest and clearest. The second method of tuning is used when it is desired to tune through a range of frequencies, such as the amateur bands. Set the Bandsread dial pointer at "100", set the Tuning control for the high end of the selected band or range of frequencies, and then tune through the range with the Bandsread control. Turning the Bandsread control from "100" to "0" tunes the receiver progressively lower in frequency.

EXT. AMPL. JACK

The External Amplifier jack, located at the rear of this receiver, permits attachment of the receiver to an external low level amplifier for the purpose of obtaining a higher level audio output or for providing audio output at some remote point in the house.

The receiver controls are operated in the same manner as for normal "receive" operation. The External Amplifier jack accepts a standard phono pin plug type connector.

SERVICE OR OPERATING QUESTIONS

For any further information regarding operation or servicing of your unit, contact your Hallicrafters dealer. The Hallicrafters Co. maintains an extensive system of authorized service centers where any required service will be performed promptly and efficiently at a nominal charge. All Hallicrafters Authorized Service Centers display the sign shown at the right. For the location of the one nearest you, consult your dealer or telephone directory.

The Hallicrafters Company reserves the privilege of making revisions in current production of equipment, and assumes no obligation to incorporate these revisions in earlier models.



92 X 1401-C

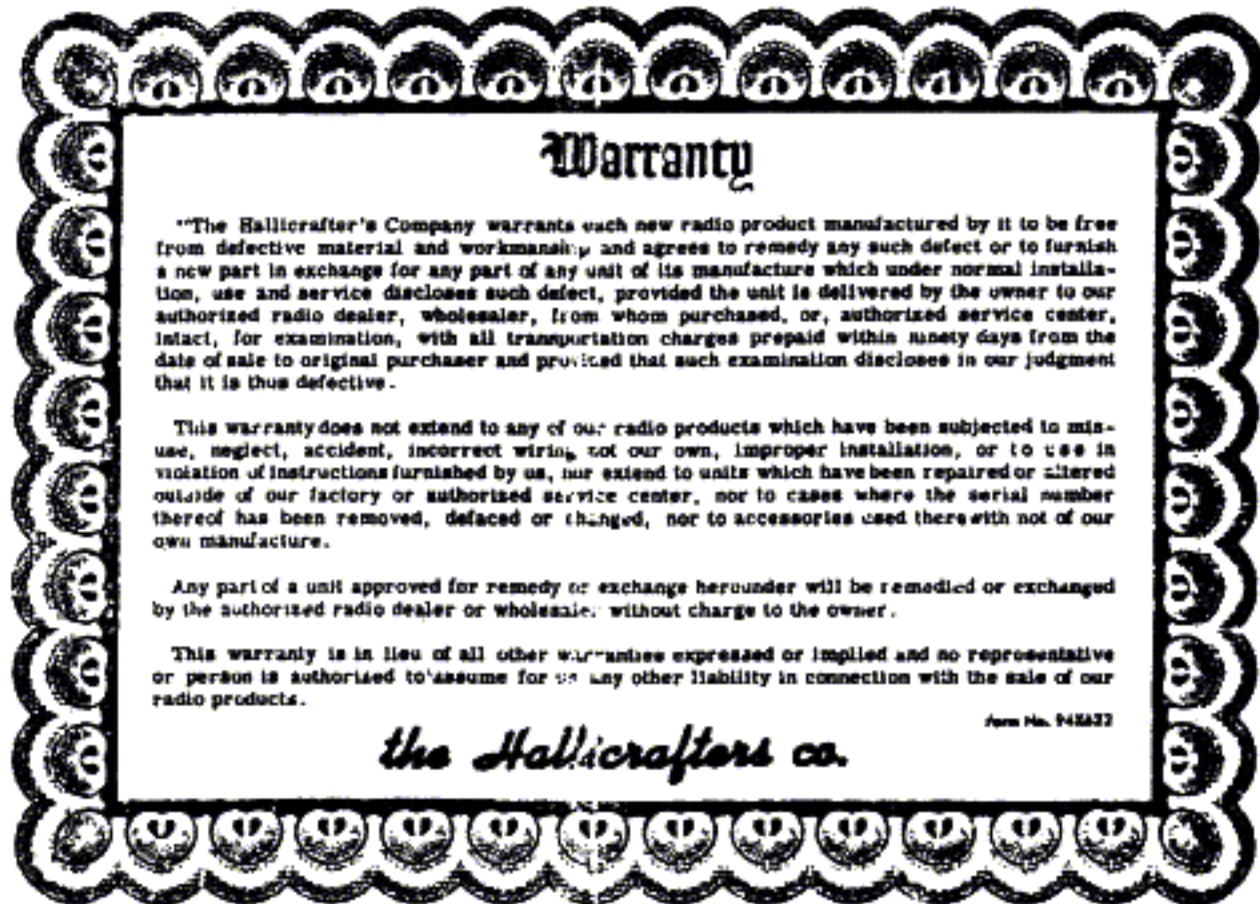

the **hallicrafters** co.

4401 WEST 5TH AVENUE

Chicago 24, Ill.

V4
6AL5
ANL/DET.

V3
6BA6
2ND.I.F.

V2
6BA6
1ST.I.F.

V1
6BA6
MIXER

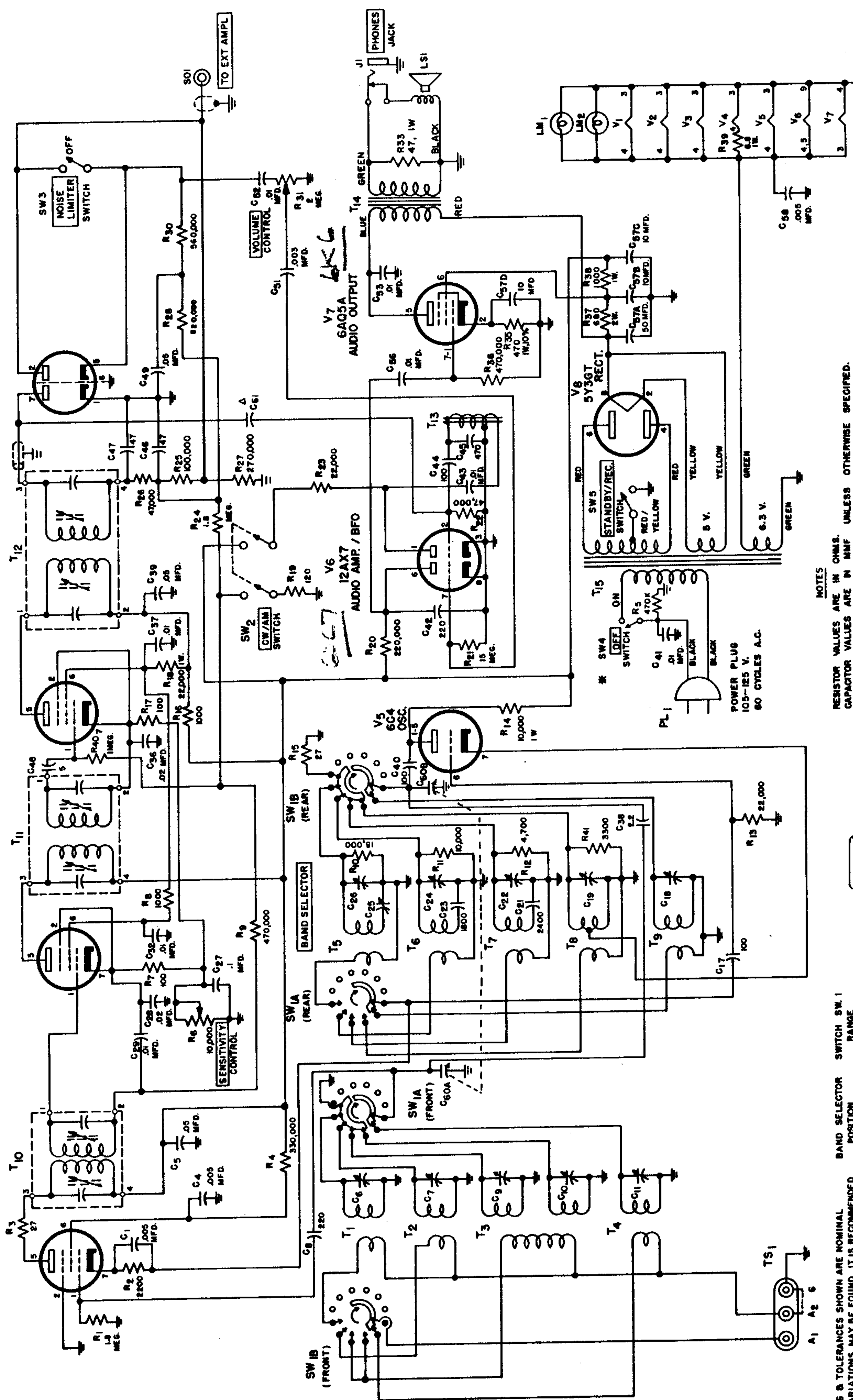

RESISTOR VALUES ARE IN OHMS.
CAPACITOR VALUES ARE IN MMF UNLESS OTHERWISE SPECIFIED.
CHASSIS
* ON-OFF SWITCH SW4 IS PART OF VOLUME CONTROL R31.
Δ WIRE GIMMICK

NOTES

BAND SELECTOR POSITION	RANGE	SWITCH SW. 1
A	540-1650 KC	
B	2.5-6.6 MC	
C	6-11 MC	
D	15.5-32 MC	
E	47-55 MC	

NOTE: SWITCH SHOWN IN POSITION E.

VALUES & TOLERANCES SHOWN ARE NOMINAL AND VARIATIONS MAY BE FOUND. IT IS RECOMMENDED THAT THE VALUE OF ANY REPLACEMENT CORRESPOND TO THE NOMINAL VALUE OF THE PART BEING REPLACED.

Figure 7. Schematic Diagram.

089-001889