

# **REALISTIC®**

**SOLID STATE**

**FOUR BAND COMMUNICATIONS RECEIVER**

**SERVICE MANUAL**

**MODEL DX-120**

**C A T. No. 20-120**

**A PRODUCT OF RADIO SHACK®**

**DIVISION OF TANDY CORPORATION**

## C O N T E N T S

1. SPECIFICATIONS
2. GENERAL ALIGNMENT INSTRUCTIONS
3. INSTRUCTIONS FOR REPLACEMENT OF CHASSIS
4. PARTS LIST
5. Fig. 1-1 TOP VIEW OF DX-120 CHASSIS PARTS LOCATION
6. Fig. 1-2 REAR VIEW OF DX-120 CHASSIS PARTS LOCATION
7. Fig. 2-1 SCHEMATIC DIAGRAM
8. Fig. 2-2 SCHEMATIC DIAGRAM
9. Fig. 3 CHASSIS DIS-ASSEMBLY
10. Fig. 4 MAIN TUNING DIAL CORD ASSEMBLY
11. Fig. 5-1 SUB CIRCUIT BOARD TOP VIEW
12. Fig. 5-2 SUB CIRCUIT BOARD REAR VIEW
13. Fig. 6-1 SUB CIRCUIT BOARD TOP VIEW
14. Fig. 6-2 SUB CIRCUIT BOARD REAR VIEW
15. Fig. 7-1 MAIN CIRCUIT BOARD TOP VIEW
16. Fig. 7-2 MAIN CIRCUIT BOARD REAR VIEW
17. Fig. 8-1 MAIN CIRCUIT BOARD TOP VIEW
18. Fig. 8-2 MAIN CIRCUIT BOARD REAR VIEW
19. Fig. 9 MAIN CIRCUIT BOARD WIRING DIAGRAM

## 1. SPECIFICATIONS

- 1.1 Circuit ..... 1 FET, 8 transistor, 8 diodes and  
2 thermistors super-heterodyne system  
Shown Table 1 and Fig. 1 Schematic diagram.
- 1.2 Frequency ..... The tuning system covers the following four  
bands:
  - 1 BAND A 0.535 - 1.6 MHz
  - 2 BAND B 1.55 - 4.5 MHz
  - 3 BAND C 4.5 - 13 MHz
  - 4 BAND D 13 - 30 MHz
- 1.3 Band spread ... Variable Capacitor (23<sub>p</sub>F max.)  
fitting for band spread system
- 1.4 Intermediate frequency ..... 455 KHz
- 1.5 Receiving sensitivity ..... 1 - 30  $\mu$ V
- 1.6 Signal to noise ratio ..... 10 dB
- 1.7 Image ratio ..... s - 50 dB
- 1.8 Audio power ..... 1 watt max.
- 1.9 Loud speaker ..... 3" x 5" PM type
- 1.10 Power input & power consumption
  - 1 AC 117V, 50/60 Hz, 6 VA
  - 2 DC 12V, 5 VA, negative ground only
- 1.11 Controls on the front
  - 1 Tuning dial
  - 2 Spread control
  - 3 "S" meter

- 4 ANL switch (ON-OFF)
- 5 Mode switch (AM/SEB, CW)
- 6 Operation switch (REC./STD. BY)
- 7 Phones jack
- 8 Power ON/OFF & AF gain control
- 9 BFO pitch
- 10 Band selector
- 11 RF gain control
- 12 Main tuning control

1.12 Controls on the back

- 1 Antenna terminal
- 2 Fuse holder and fuse
- 3 DC/AC change switch
- 4 DC 12V power jack

Table 1. Transistor & diode complement

Number	Type	Function
Q 1	2SK19 (FET)	Mixer
Q 2	2SC668	Oscillator
Q 3	2SC372	Beat Frequency Oscillator
Q 4	2SC372	1st IF amplifier
Q 5	2SC372	2nd IF amplifier
Q 6	2SC373	1st Audio amplifier
Q 7	2SC373	2nd Audio amplifier
Q 8, 9	2SD72	Audio output power amplifier

Number	Type	Function
D 1	1N34A	Stabilizer
D 2	1N34A	Detector for AVC
D 3	1N34A	Detector for AM
D 4	1N34A	Detector for ANL
D 5, 6	FR-1	Rectifier
D 7	Zener diode	Voltage regulator for overall circuit
D 8	Zener diode	Voltage regulator for local oscillator and BFO circuit
D 9	1N34A	Detector for AVC
Th 1, 2	D-1E	Temperature compensator

Remarks: Transistor type and rating may be revised for improvements.

## 2. GENERAL ALIGNMENT INSTRUCTIONS

### 2.1 Test equipments

- 1 Standard signal generator or Test oscillator
- 2 Vacuum tube voltmeter (P type)
- 3 Vacuum tube voltmeter (AC/DC)
- 4 Dummy load 8 ohms

### 2.2 General alignment conditions

- 1 Before servicing this receiver, disconnect from the power source and remove all lead wires attached to terminal connections.

A. S.G. Coupling .....

Connect the cable of S.G. output through a dummy antenna between antenna and GND on the antenna terminal.

B. S.G. Frequency .....

Three points characteristic alignment should be required on each A to D pass band. The plot frequency and modulation shall be positioned as follows :

BAND A ..... 0.6MHz, 1MHz & 1.4MHz

BAND B ..... 1.7MHz, 2.8MHz & 4MHz

BAND C ..... 5MHz, 8MHz & 12MHz

BAND D ..... 14MHz, 21MHz & 28MHz

MODULATION .... 1KHz, 30%

C. Connect V.T.V.M .....

Connect a AC vacuum tube voltmeter to the phones jack with 8 ohms dummy load. Keep clear of low impedance speaker voice coil.

D. Adjust .....

Adjust the cores and trimmers of antenna and oscillator coils for maximum deflection. Part number of the core and trimmers is as following table;

STAGE ADJ. BAND	ANT. STAGE		OSC. STAGE	
	CORE	TRIM.	CORE	TRIM.
BAND A	L 1	C 101	L 5	C 105
BAND B	L 2	C 102	L 6	C 106
BAND C	L 3	C 103	L 7	C 107
BAND D	L 4	C 104	L 8	C 108

Remove the four screws which fasten the chassis to the bonnet, speaker leads and remove the six screws which fasten the chassis to the bottom plate. Show Item 3.1 Chassis disassembly, Fig. 3.

-2 Knob function and it nominal position

Tuning dial ..... 0, on logical scale  
Spread dial ..... VC minimum position  
ANL switch ..... OFF  
Mode switch ..... AM  
OPR switch ..... REC.  
BFO switch ..... -  
AF gain control ..... Adjust to test requirements  
RF gain control ..... Maximum

-3 IF amplifier alignment

Note; The non metallic alignment tool are required for complete alignment. Unless otherwise specified, all front panel controls shall be positioned as Item 2.2-2 knob function and nominal position for complete alignment of the receiver. The receiver should be warmed up for a period of at least 1/2 hour before proceeding with the complete alignment.

- A. S.G. Coupling .....  
Connect the S.G. output through a capacitor (50 pF) between VC-1 and chassis earth.
- B. S.G. Frequency ..... 455 KHz
- C. Adjust .....  
Adjust the cores of IF transformer T1, T2 & T3 for a maximum deflection on the "S" meter in a front panel.

-4 RF amplifier alignment

Note; Alignment tool, nominal position of knobs and receiver condition should be required as Item 2.2 - 2 and 2.2 - 3.

-5 B.F.O. Alignment

Note; The non-metallic alignment tool are required for complete alignment. The B.F.O. switch on the front panel should be positioned ON. A knob of the B.F.O. pitch on the front panel should be positioned one clock.

A. Signal Coupling .....

Receive one of a broadcast frequency with exactitude by an antenna through the antenna terminal.

B. Adjust .....

Adjust the core of the B.F.O. coil T-4 for a zero beat note by loud speaker.

-6 Voltage chart

MODEL : DX-120

Symbol Number of Transistor	Transistor	Collector (V)	Emitter (V)	Base (V)
Q1	2SK19	* D=6.2	* S=1.1	* G=0
Q2	2SC668	6.5	0.7	1.25
** Q2	2SK19	* D=6.5	* S=0.3	* G=0
Q3	2SC372	5	0.5	0.75
Q4	2SC372	6.3	0.75	1.4
Q5	2SC372	6.5	0.4	1
Q6	2SC373	6.5	0.1	0.55
Q7	2SC373	12.5	0.3	0.45
Q8	2SD72	14	7	7.2
Q9	2SD72	7	0	0.2

Remarks: \*D = drain \*S = source \*G = gate

\*\* Q2 2SK19 revised from 2SC668 after serial No. 7211



3. INSTRUCTIONS FOR REPLACEMENT OF CHASSIS AND  
INSTRUCTIONS FOR DIAL CORD ASSEMBLY

3.1 Chassis disassembly

Show Fig. 3 and Item 2.2-1

Note; Before the chassis disassembly, pull out two of  
tips with speaker lead from loud speaker.

3.2 Dial cord assembly

Main tuning dial cord assembly show the Fig. 4.

3.3 Knob setting position for B.F.O. pitch

Set the knob slit on nine clock when a capacity of variable  
capacitor should be maked maximum value.

4.1 Parts list and description for serial No. 1011-7210

PARTS LIST AND DESCRIPTION

Symbol No. or Item No.	Description	Rating or Stock No.	Remarks
Q 1	Transistor	2SK19	Selected
Q 2	"	2SC668B	Selected
Q 3,4,5	"	2SC372	
Q 6,7	"	2SC373	
Q 8,9	"	2SD72	
D 1,2,3,4,9,	Diode	1N34A	
D 7	Zener Diode	SZ-9V	
D 8	"	SZ-7V	
D 5,6	Rectifier	RF-1P/S1-802	
Th 1,2	Thermister	D-1E	
T-1,2,3	<u>I. F. Transformer</u>		
T-4	B. F. O. Transformer	15232	
T-5	Input Transformer	S-9563	
T-6	Power Transformer	R-6216	
L-1	BC. Antenna Coil	DX-120	
L-2	SW-1 "	"	
L-3	SW-2 "	"	
L-4	SW-3 "	"	
L-5	SW-1 Osc Coil	"	
L-6	SW-2 "	"	

Symbol No. or Item No.	Description	Rating or Stock No.	Remarks
L-7	SW-3 Osc Coil	DX-120	
L-8	SW-4 "	"	
L-9	RF Choke Coil	2 mH	
S1a-d	Band Switch	Y-264-120	
S 2,3,4	Slide Switch	14L-120	
S 5	Combined on VR-2		VR-2
S 6	Slide Switch	9L-120	
VC-1	Main Tuning	2HA-43A	
VC-2	Spread	802	
VC-3	B.F.O.	GE-11C-561	
Trimmer	Antenna	AT4-51	
"	Oscillator	B4-1M2	
VR-1	RF Gain Control	PR24-10K	
VR-2	AF Gain Control w/sw	S425-10KA	
Lamp (P.L.)	Pilot Lamp for Dial	SWAN 8V	
	Foot	No. 20 Nylon	
	Lamp Socket	8V	
	Cord Stopper	UL Type	
	3P DC Supply Socket	3P	
	Antenna Terminal	2P	DX-120
	Lug for AC Line	UL Type	
J-1	Phones Jack	S-G-320T	
	Power Cord	UL Type	Black
	Speaker	121-19D	
M	"S" Meter	SNK-30	DX-120

Symbol No. or Item No.	Description	Rating or Stock No.	Remarks
	Heat Sink "L"	DX-120	
	TR Holder	"	
	Main Pulley	90 $\phi$	
	Dial Pulley		
	Dial Spring	13 mm	DX-120
	Shaft Sleeve	GE-13A-954	
	Tuning Shaft		
	Stud for Dial Plate		
	Pulley Shaft	GE-12A-801	
	Bar Ant. Holder		
	Front Panel	DX-120	
	Dial Plate	DX-120	
	Control Knob	"	
	Back Plate	"	
	Coils Chassis	"	
	Shield Plate	"	
	Bracket for Band Switch	"	
	Main Chassis	"	
	Bonnet	"	
	Bottom Plate	"	
	Dial Pointer	DX-120	
	"L" for Sub PC		
	Back Plate for Dial	DX-120	
	Printed Circuit Board	GE-12C-970	

Symbol No. or Item No.	Description	Rating or Stock No.	Remarks
	Printed Circuit Board	GE-12C-971	
C 40	Chemical Condenser	1MF/6V	
C 42	"	3MF/15V	
C 6	"	5MF/6V	
C 37	"	10MF/6V	
C 43	"	30MF/6V	
C 31	"	30MF/15V	
C 47	"	50MF/15V	
C 45, 49	"	200MF/15V	
C 50	"	500MF/15V	
C 48	"	2000MF/25V	
C 52	"	50MF/3V	Meter
C 46	Mylar Condenser	0.005MF/50V	
C 51	Ceramic "	100PF/25V	
C 27	"	2PF/25V	
C 41	"	50PF/25V	
C 4,5,34,38	"	0.01MF/25V	
C 33	"	0.02MF/25V	
C 7,8,19,20 22,26,28 29,30,32	"	0.04MF/25V	
C 35,36,39	"	0.1MF/25V	
C 12	Polyester Condenser	5PF/25V	Ser. No. 1000 - 5000 used 10PF
C 1	"	10PF/25V	

Symbol No. or Item No.	Description	Rating or Stock No.	Remarks
C 42	Polyester Condenser	50PF/25V	
C 13	"	55PF/25V	
C 2	"	65PF/25V	
C 17	"	300PF/25V	
C 9	"	450-470PF/25V	
C 25,16	"	500/25V	
C 15	"	550-820PF/25V	
C 23, 3	"	1000PF/25V	
C 10	"	1500PF/25V	
C 11,14	"	5000PF/25V	
C 18,21	"	10000PF/25V	
C 51	Oil Capacitor	0.001MF/600V	UL Type
R 42	Resistor 1/2W	0.5 ohms	
R 40,41	"	4.7 "	
R 34	Resistor 1/4W	22 "	
R 36,37	"	47 "	
R 43	"	180 "	
R 35	"	220 "	
R 14,18,21 27,33,44	"	470 "	
R 3,5,6,8 12,19	"	1K "	
R 4	"	47K "	
R 20	"	3.3K "	
R 11,16	"	4.7K "	

Symbol No. or Item No.	Description	Rating or Stock No.	Remarks
R 31	Resistor 1/4W	6.8K "	
R 7,10,15 22,23,25 26,30	"	10K "	
R 17	"	27K "	
R 32	"	39K "	
R 1	"	1M "	
R 28	"	2M-2.2M "	
R 13	"	15K "	
R 45	"	820 "	
R 37,39	"	1.8K "	
R 29	"	150(220) "	
R 2	"	2.2K "	
R 9	"	2.7K-4.7K "	
R 46	"	120 "	
R 24	"	470K "	

4.2 Parts list and description for serial No. 7211

PARTS LIST AND DESCRIPTION

Symbol No. or Item No.	Description	Rating or Stock No.	Remarks
Q 1	Transistor	2SK19	Selected
Q 2	"	2SK19	Selected
Q 3,4,5	"	2SC372	
Q 6,7	"	2SC373	
Q 8,9	"	2SD72	
D 1,2,3,4,	Diode	1N34A	
D 7	"	SZ-9V	
D 8	"	SZ-7V	
D 5,6	Rectifier	RF-1P/S1-802	
Th 1,2	Thermister	D-1E	
T-1	I. F. Transformer	YOC-15000A	
T-2	"	YOC-15001A	
T-3	"	YMC-15002A	
T-4	B. F. O. Transformer	15232	
T-5	Input Transformer	S-9563	
T-6	Power Transformer	R-6216	
L-1	BC. Antenna Coil	DX-120	
L-2	SW-1 "	"	
L-3	SW-2 "	"	
L-4	SW-3 "	"	



Symbol No. or Item No.	Description	Rating or Stock No.	Remarks
L-5	SW-1 Osc Coil	DX-120	
L-6	SW-2 "	"	
L-7	SW-3 "	"	
L-8	SW-4 "	"	
Sla-d	Band Switch	Y-264-120	
S 2,3,4	Slide Switch	14L-120	
S 5	Combined on VR-2		VR-2
S 6	Slide Switch	9L-120	
VC-1	Main Tuning	2HA-43A	
VC-2	Spread	802	
VC-3	B. F. O.	GE-11C-561	
C101-104	Antenna Trimmer	AT4-51	
C105-108	Oscillator Trimmer	B4-1M2	
VR-1	RF Gain Control	PR24-10K	
VR-2	AF Gain Control w/sw	S425-10KA	
Lamp (P.L.)	Pilot Lamp for Dial	SWAN 8V	
	Foot	No. 20 Nylon	
	Lamp Socket	8V	
	Cord Stopper	UL Type	
	3P DC Supply Socket	3P	
	Antenna Terminal	2P	DX-120
	Lug for AC Line	UL Type	
J-1	Phones Jack	S-G-320T	
	Power Cord	UL Type	Black
	Speaker	121-19D	

Symbol No. or Item No.	Description	Rating or Stock No.	Remarks
M	"S" Meter	SNK-30	DX-120
	Heat Sink "L"	DX-120	
	TR Holder	"	
	Main Pulley	90 $\phi$	
	Dial Pulley		
	Dial Spring	13 mm	DX-120
	Shaft Sleeve	GE-13A-954	
	Tuning Shaft		
	Stud for Dial Plate		
	Pulley Shaft	GE-12A-801	
	Bar Ant. Holder		
	Front Panel	DX-120	
	Dial Plate	DX-120	
	Control Knob	"	
	Back Plate	"	
	Coils Chassis	"	
	Shield Plate	"	
	Bracket for Band Switch	"	
	Main Chassis	"	
	Bonnet	"	
Bottom Plate	"		
Dial Pointer	DX-120		
"L" for Sub PC			
Back Plate for Dial	DX-120		

Symbol No. or Item No.	Description	Rating or Stock No.	Remarks
	Printed Circuit Board	GE-12C-970A	
	Printed Circuit Board	GE-12C-971	
C 37	Chemical Condenser	1MF/16V	
C 39	"	3MF/16V	
C 6	"	5MF/16V	
C 20	"	10MF/16V	
C 12-40	"	30MF/16V	
C 16-43	"	50MF/16V	
C 41-45	"	200MF/16V	
C 46	"	500MF/16V	
C 44	"	2000MF/25V	
C 42	Mylar Condenser	0.005MF/50V	
C 36	Ceramic "	2PF/25V	
C 48	"	10PF/25V	
C 47	"	20PF/25V	
C 38	"	50PF/25V	
C 14	"	100PF/25V	
C 4,5,17,21	"	0.01MF/25V	
C 15	"	0.02MF/25V	
C 7,8,9,10,11 13,31,35,30	"	0.04MF/25V	
C 18,19,22	"	0.1MF/25V	
C 1	Polyester Condenser	10PF/25V	
C 27	"	20PF/25V	
C 32	"	51PF/25V	

Symbol No. or Item No.	Description	Rating or Stock No.	Remarks
C 28	Polyester Condenser	68PF/25V	
C 29	"	150PF/25V	
C 24	"	470PF/25V	
C 33	"	500PF/25V	
C 3,34	"	1000PF/25V	
C 25	"	1500PF/25V	
C 26	"	5000PF/25V	
C 23	"	10000PF/25V	
C 49	Oil Condenser	0.001MF/600V	UL Type
R 45	Resistor 1/2W	0.5 ohms	
R 42,43	"	4.7 "	
R 36	Resistor 1/4W	22 "	
R 38,40	"	47 "	
R 1	"	120 "	
R 24,33	"	150 "	
R 28	"	180 "	
R 37	"	220 "	
R 12,14,20, 29,35,44	"	470 "	
R 4	"	820 "	
R 5,7,8,13 26	"	1K "	
R 39,41	"	1.8K "	
R 3	"	2.2K "	
R 15	"	3.3K "	

Symbol No. or Item No.	Description	Rating or Stock No.	Remarks
R 9,25	Resistor 1/4W	4.7K ohms	
R 34	"	6.8K "	
R 11,16,17 18,21,31	"	10K "	
R 27	"	15K "	
R 10	"	27K "	
R 32	"	39K "	
R 6,23	"	47K "	
R 19	"	470K "	
R 2	"	1M "	
R 28	"	2.2M "	



Fig. 1-1 TOP VIEW OF DX-120 CHASSIS PARTS LOCATION

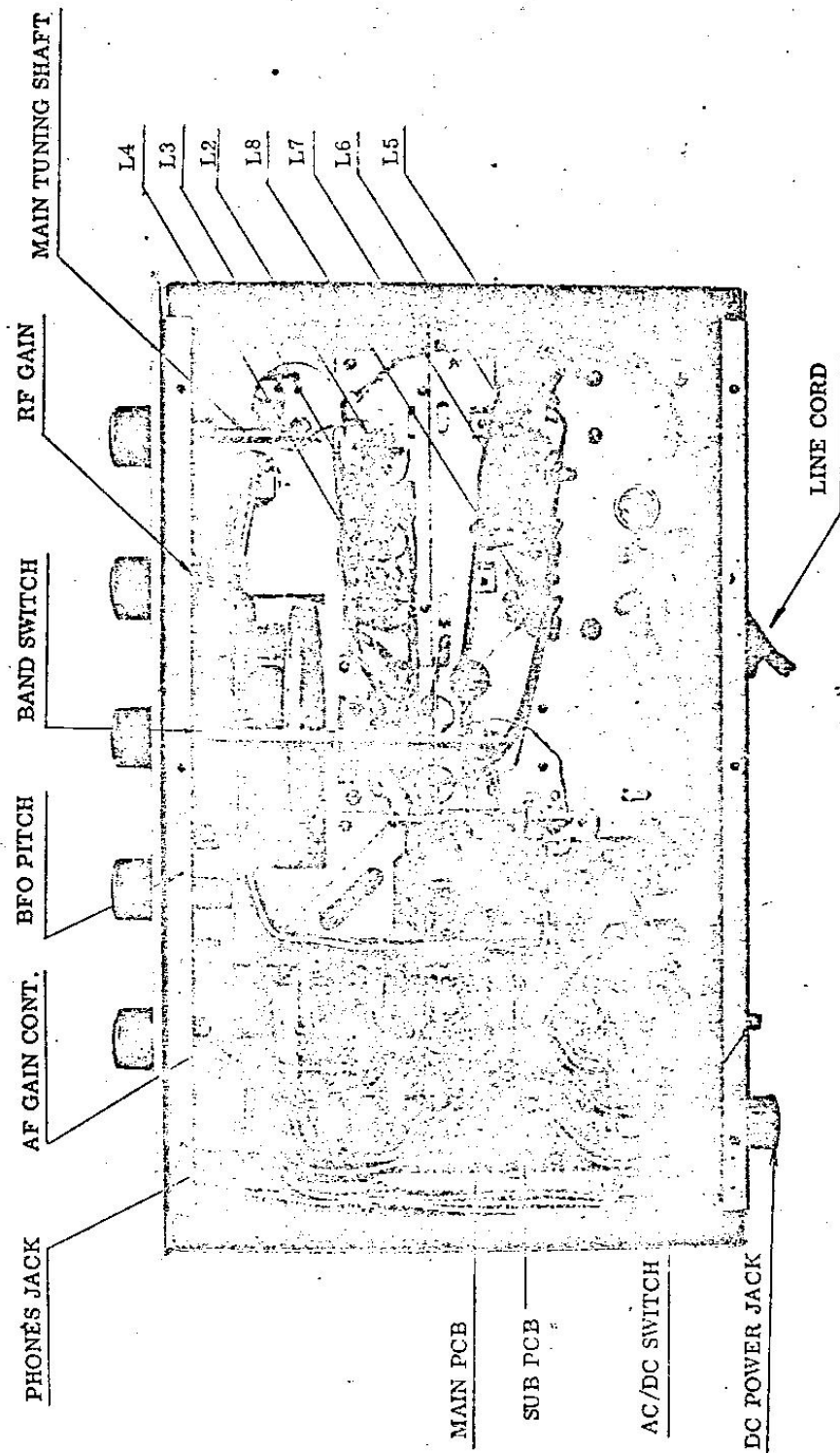
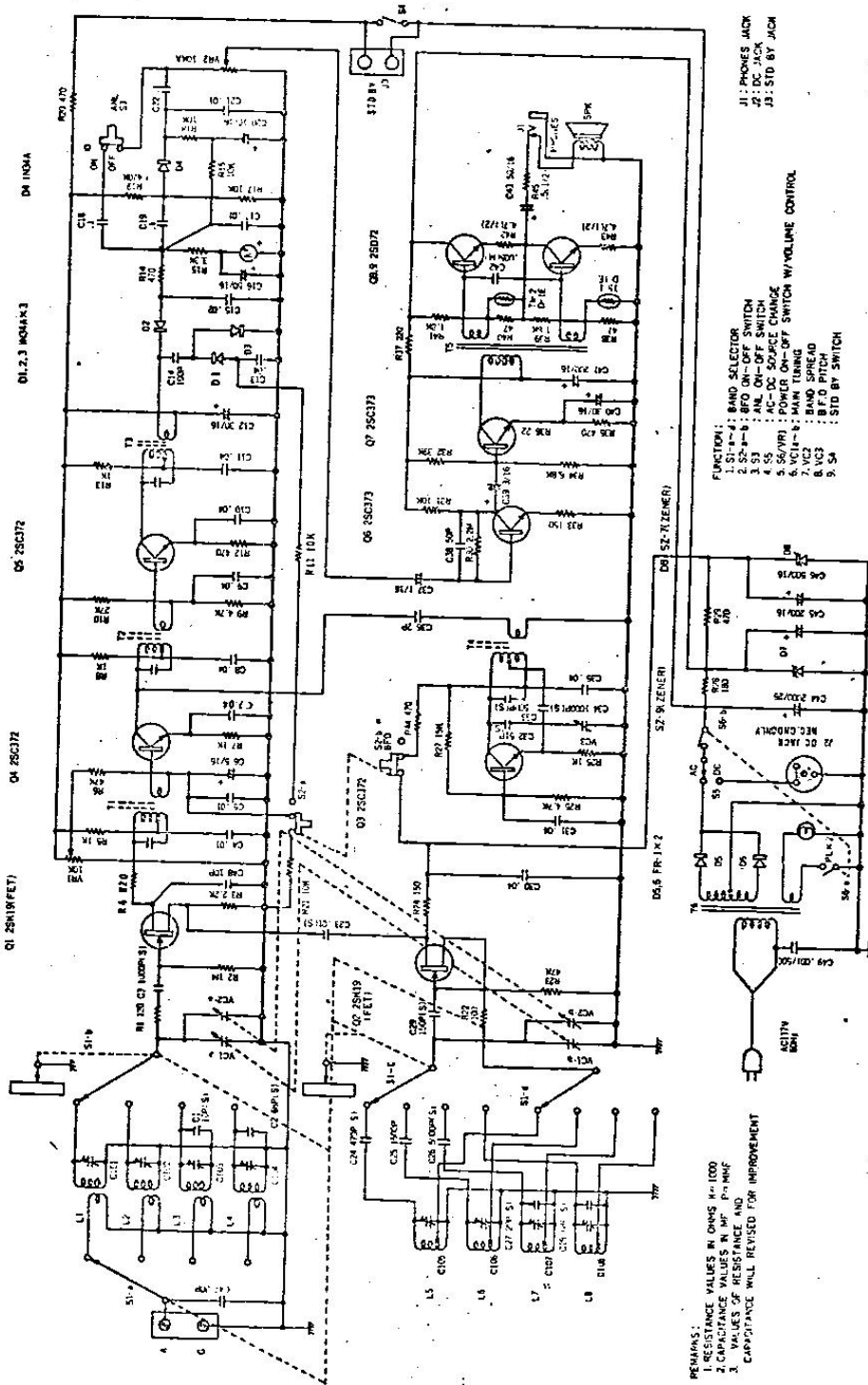

Fig. 1-2 REAR VIEW OF DX-120 CHASSIS PARTS LOCATION





For after serial # 7211



- FUNCTION:
- 1. BAND SELECTOR
  - 2. ON-OFF SWITCH
  - 3. S3
  - 4. S5
  - 5. S6/VR1
  - 6. S7/VR2
  - 7. S8/VR3
  - 8. S9/VR4
  - 9. S10
11. POWER JACK  
12. DC JACK  
13. STD. BY JACK
- POWER ON-OFF SWITCH W/VOLUME CONTROL

REMARKS:  
1. RESISTANCE VALUES IN OHMS  
2. CAPACITANCE VALUES IN MF, P, OR NF  
3. VALUES OF RESISTANCE AND CAPACITANCE WILL BE REVISED FOR IMPROVEMENT

Fig. 2-2 SCHEMATIC DIAGRAM

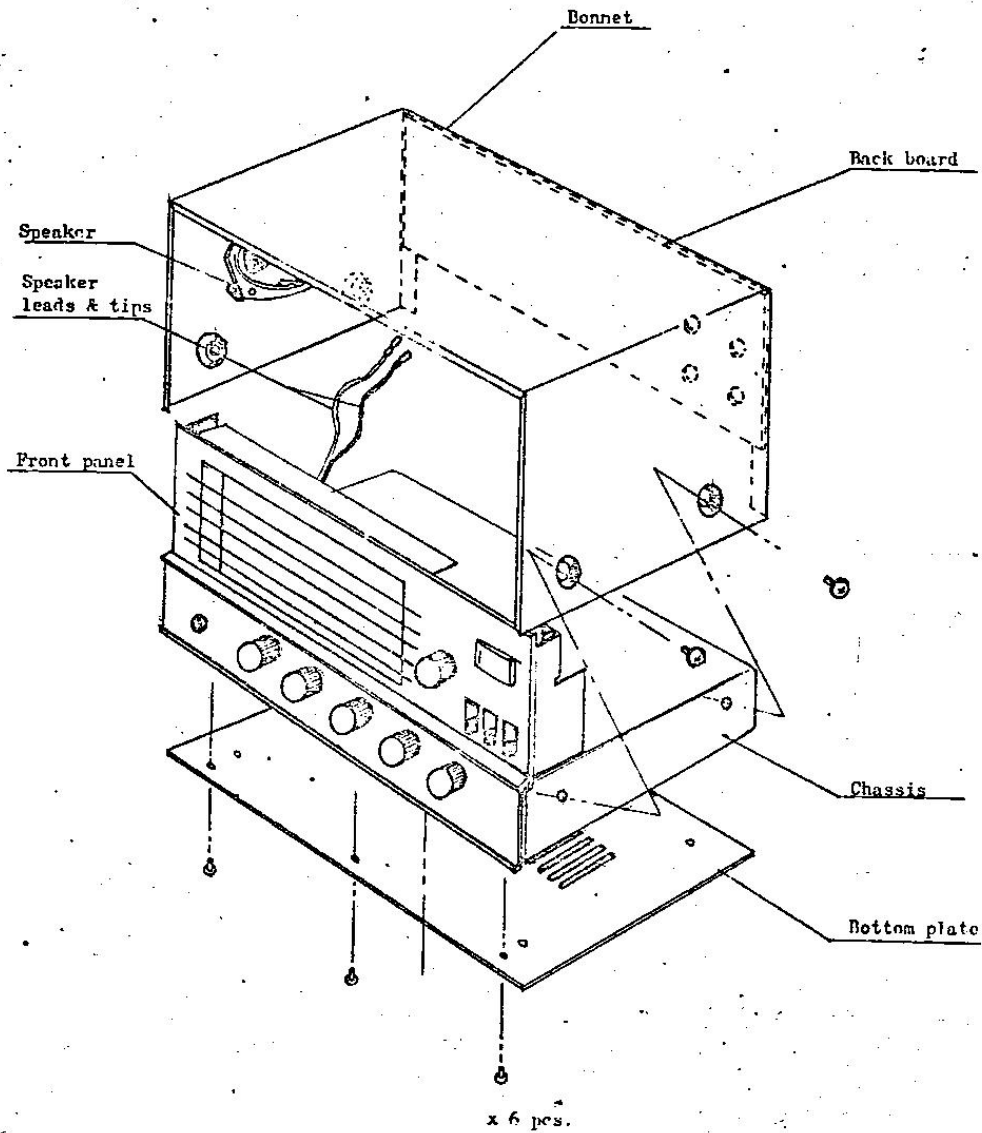

Note : Before the chassis dis-assembly,  
 take pull out two of tips with  
 speaker lead wires.

Fig. 3 CHASSIS DIS-ASSEMBLY

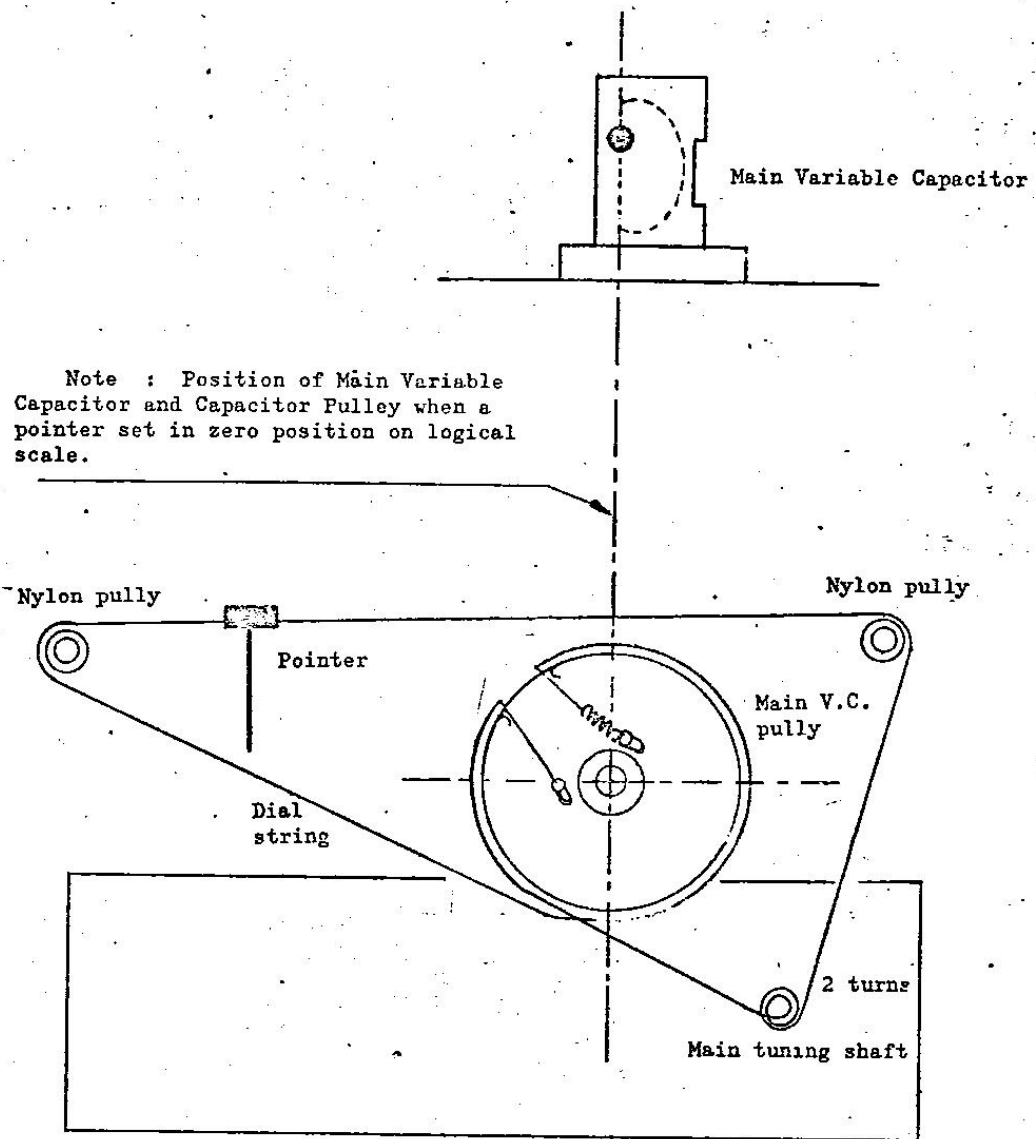

Fig. 4 MAIN TUNING DIAL CORD ASSEMBLY

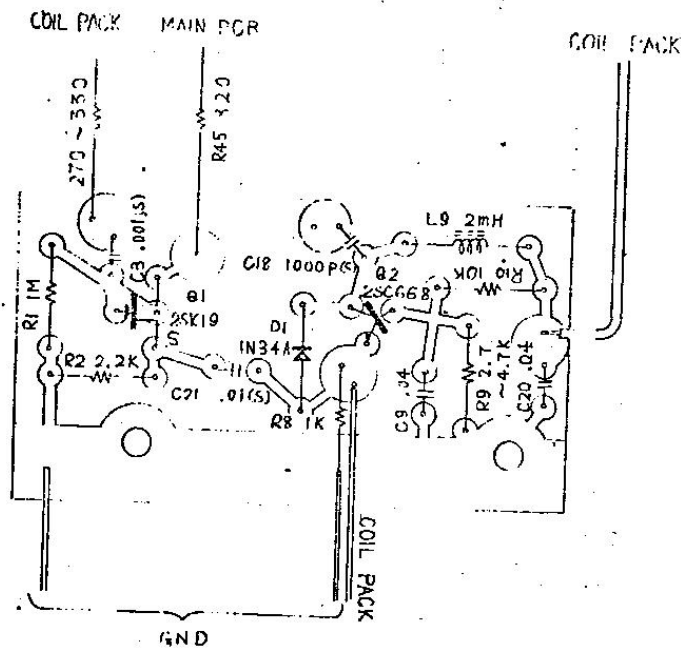

Fig. 5-1

DX-120 SUB CIRCUIT BOARD & WIRING DIAGRAM (TOP VIEW)  
SERIAL NO.1011 TO NO.7210

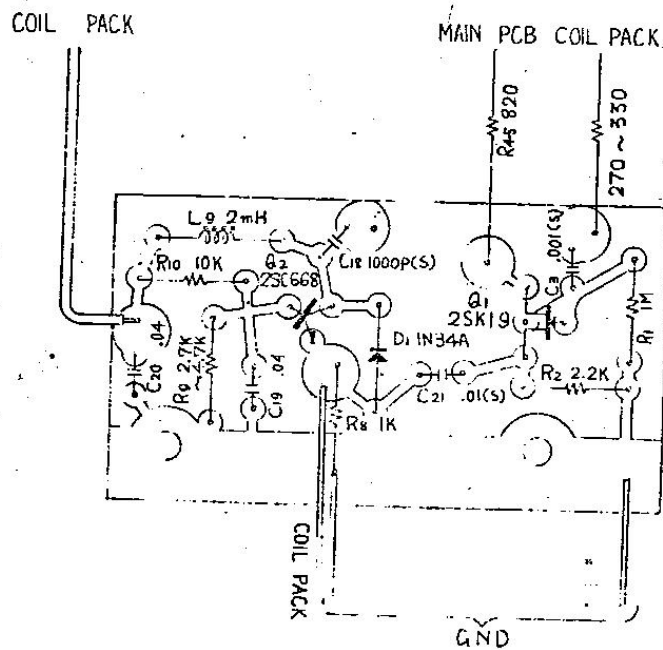

Fig. 5-2

DX-120 SUB CIRCUIT BOARD & WIRING DIAGRAM (REAR VIEW)  
SERIAL NO.1011 TO NO.7210

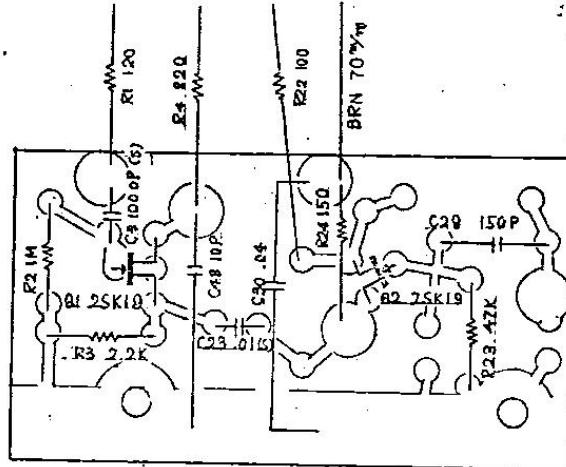

Fig. 6-1. DX-120 SUB CIRCUIT BOARD & WIRING DIAGRAM (TOP VIEW) SERIAL NO. AFTER 7211

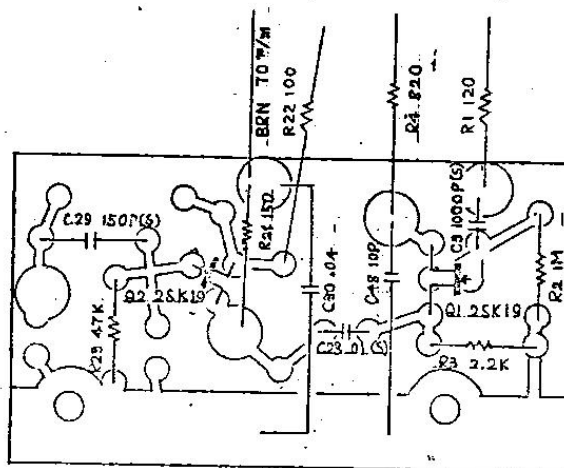

Fig. 6-2 DX-120 SUB CIRCUIT BOARD & WIRING DIAGRAM (REAR VIEW) SERIAL NO. AFTER 7211

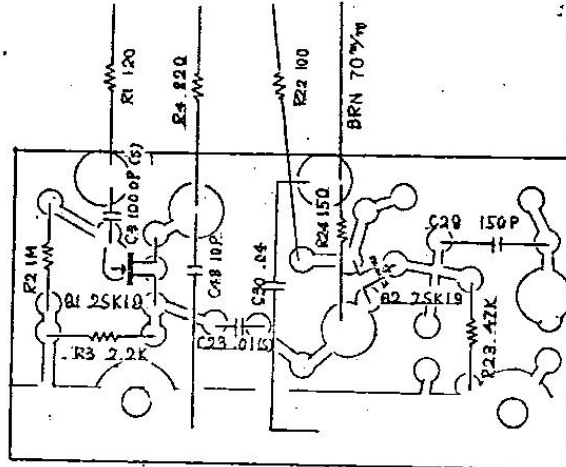

Fig. 6-1. DX-120 SUB CIRCUIT BOARD & WIRING DIAGRAM (TOP VIEW) SERIAL NO. AFTER 7211

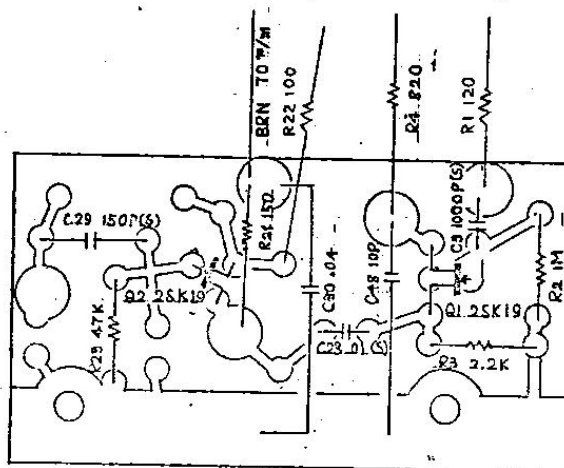

Fig. 6-2 DX-120 SUB CIRCUIT BOARD & WIRING DIAGRAM (REAR VIEW) SERIAL NO. AFTER 7211

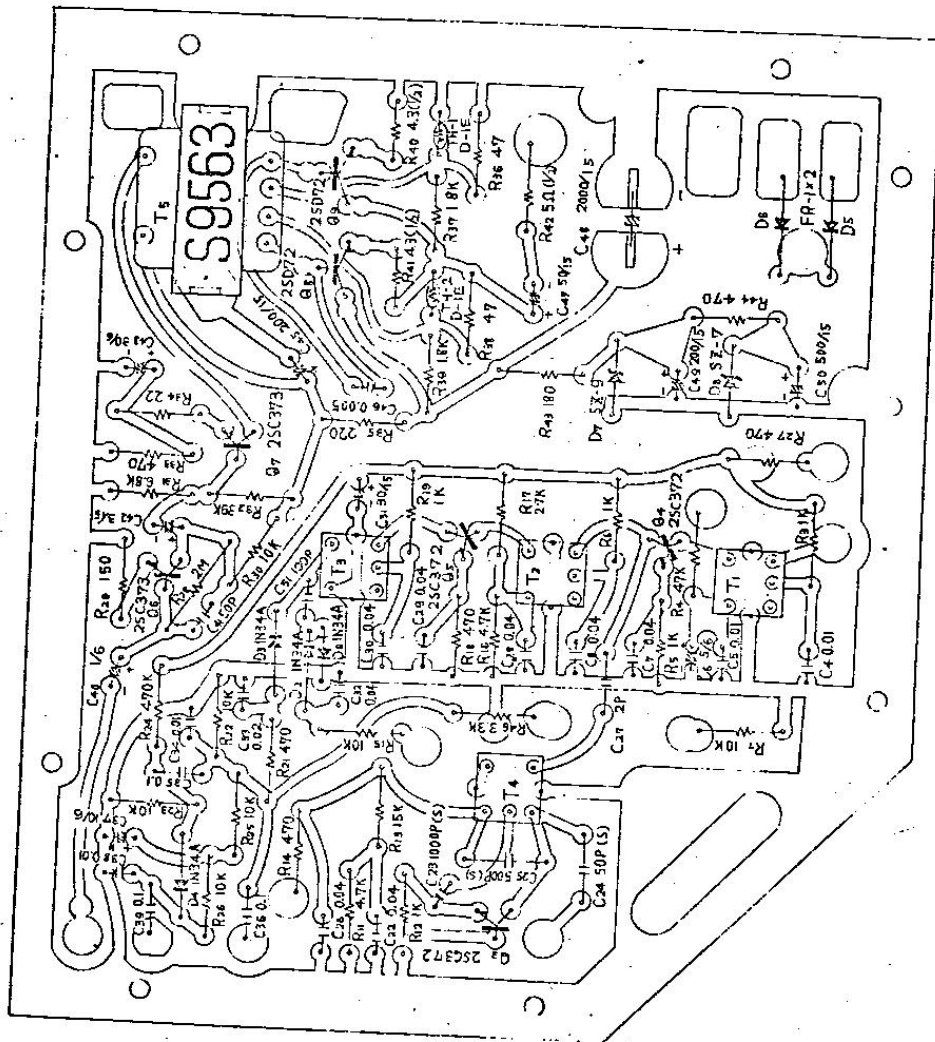

Fig. 7-1 DX-120 MAIN CIRCUIT BOARD DIAGRAM (TOP VIEW)  
SERIAL NO. 1011 TO 7210

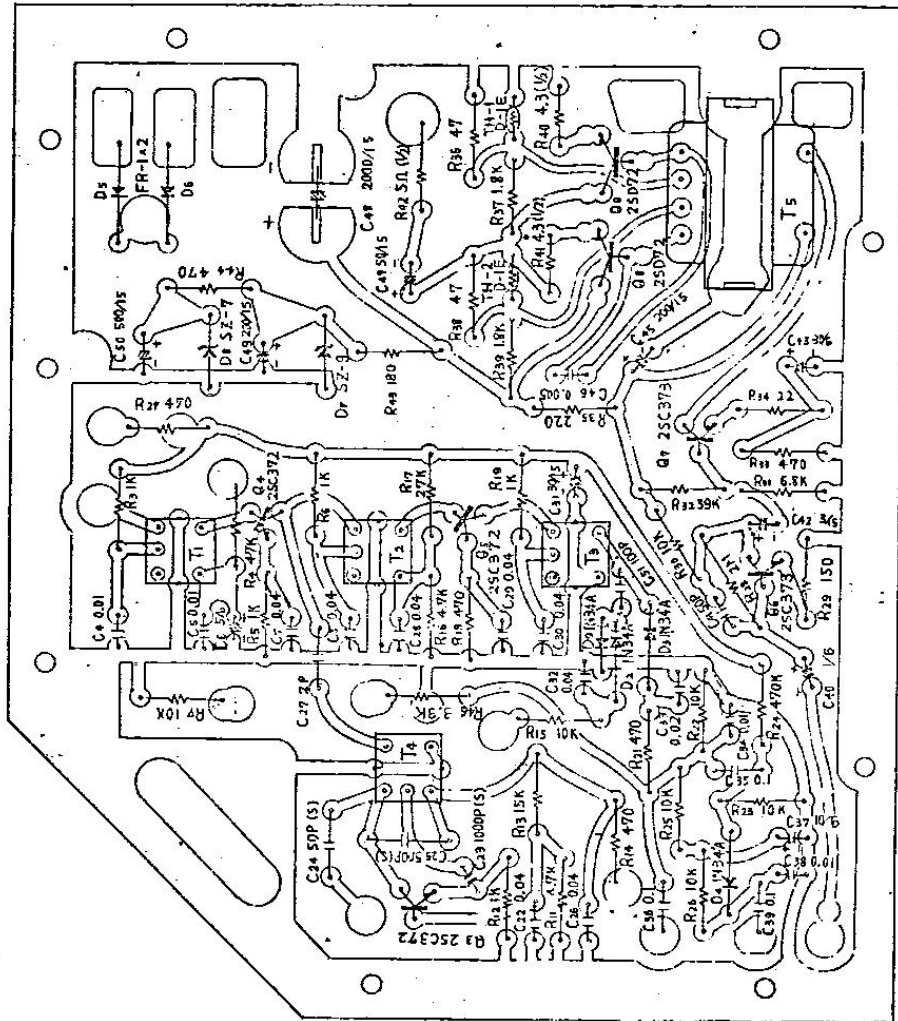

Fig. 7-2 DX-120 MAIN CIRCUIT BOARD DIAGRAM (REAR VIEW)  
 SERIAL NO. 1011 TO 7210



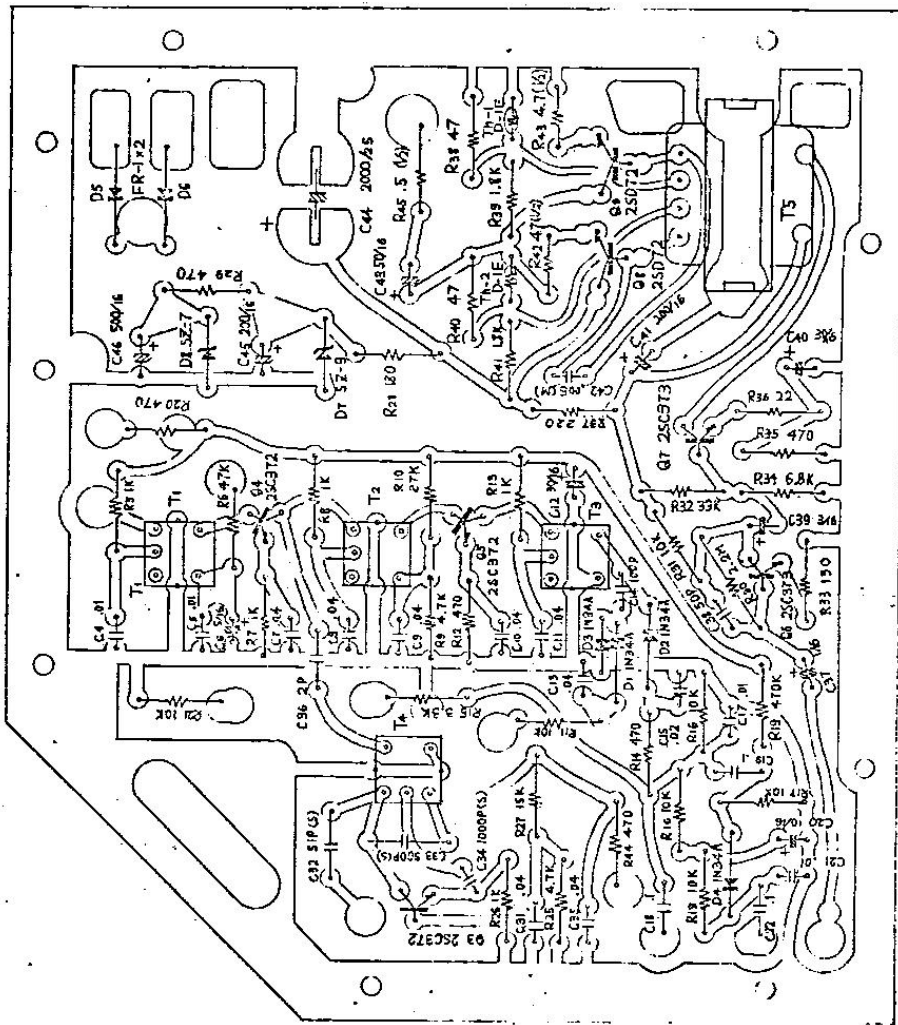

Fig. 8-2 DX-120 MAIN CIRCUIT BOARD DIAGRAM (REAR VIEW  
SERIAL NO. AFTER 7211

