

NOTES on the HEATHKIT HN-31 CANTENNA

HISTORY

CONSTRUCTION

ALL ABOUT THE RESISTOR

SOURCES of SUPPLY

OIL and HEAT PROPERTIES

PERFORMANCE MEASUREMENTS



by

John White VA7JW

FEBRUARY 2012 ©
Revision 1

HISTORY

The Heathkit HN-31 sold between 1961 and 1983 for \$9.95 as a 50 ohm dummy load without cooling oil; that was not included! The task of sourcing the appropriate oil fell to the buyer to purchase. Chuck Pensions book¹ estimates that sales of the HN-31 were in the order of 200,000 units between 1961 and 1972. He further states that "The Cantenna RF Load is undeniably the longest running, most successful product Heath ever made". One might have to agree since the MFJ-250 and Vectronic's ALD-1500 are of a similar design and are still offered today.

The author purchased the HN-31 model in 1968. The oil used is Heathkit recommended white mineral oil purchased from a pharmacy and is of medicinal / food grade quality. The other oil option is transformer oil, but it is more difficult to source.

The dummy load has been used for many years and remains in apparent excellent condition. The resistance measures 49.4 ohms DC, the oil is visually clear, there is no evidence of contamination by water or rust or any other particulate matter, and the paint pail is mechanically sound.

Page 2



SPECIFICATIONS

Impedance	50 Ω.
Voltage Standing Wave Ratio (VSWR),	Less than 1.5 up to 300 mc.
	Less than 2.0 up to 400 mc.
Power Dissipation Capability,	1 kilowatt maximum (ICAS).
Size,	8-7/8" high x 7" diameter, overall.
Net Weight,	1-1/2 lbs (oil not included).
Shipping Weight,	2-1/2 lbs.

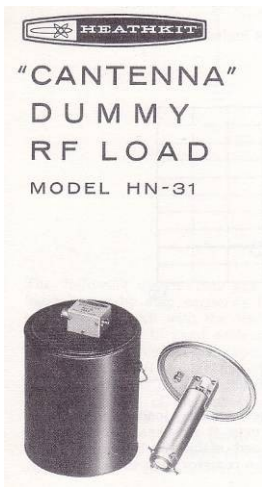

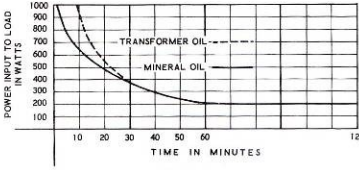

Figure 1

CIRCUIT DESCRIPTION

The Model HN-31 "Cantenna" Dummy RF Load was designed as a small convenient package capable of handling a kilowatt of power. (See Figure 1 above). The oil-cooled, temperature-stable resistive element provides a very low VSWR (voltage standing wave ratio) up to 400 megacycles. A special circuit is incorporated to provide a DC voltage for monitoring relative output power.

Refer to the Schematic Diagram on Page 3 for a better understanding of the following description.

When power is applied to the circuit, R1, the 50 Ω resistor element (dummy load), absorbs this power and converts it into heat. The heat is dissipated into and stabilized by the oil bath which envelops the resistor element.

The output circuit, used for monitoring, is isolated from the 50 Ω resistor element (input circuit) by R2. This relatively high impedance separation allows only a portion of the input voltage to pass to R3 of the output circuit. The voltage developed across R3 is presented to D1. (Keep in mind that this voltage is relative to the input RF power). Half-wave diode rectifier D1, combined with filter capacitor C1, presents a DC output voltage for monitoring purposes.

Figure 1
HN-31 Manual Excerpts dated 11 / 26 / 65
Reference 1 at End of Article

HEATHKIT HN-31 INTERNAL CONSTRUCTION

For those unfamiliar with the construction of the HN-31, some of the manual assembly diagrams are reproduced here. Notably, there is a tubular sleeve enclosing the resistor element providing two functions. One obvious function is mechanical support for the resistor and electrical return for the far end of the resistor to the ground connection on the lid. The other purpose of the sleeve is to provide a measure of impedance continuity down the length of the resistor element to extend the high frequency SWR performance.

¹ "Heathkit - A Guide to the Amateur Radio Products". Second Edition, May 2003, pg 325

NOTES on the HEATHKIT HN-31 CANTENNA

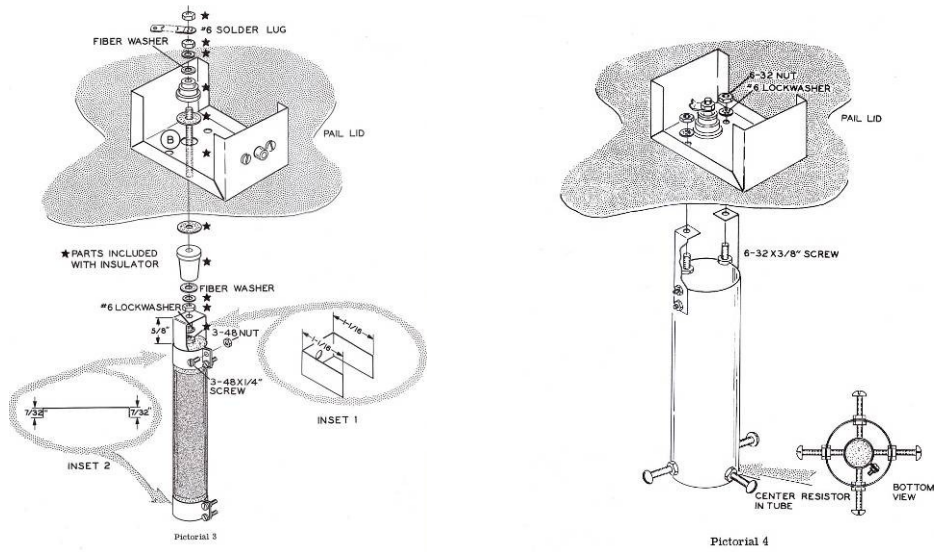

Figure 2
HN-31 Interior Construction

THE LOAD RESISTOR

The performance of the dummy load has mostly to do with the resistor characteristics. It is a ceramic tube coated with a carbon / graphite film that yields a nominal resistance of 50 ohms. Note that no tolerance is specified in the HN-31 manual although it is known to be +/- 10% from the manufacturer's specifications. The resistor must also be able to dissipate power levels in excess of 1000 Watts and remain stable. This requirement means that it must operate at rather high temperatures and voltages. In all cases the resistor must not alter its properties.

The resistor is specifically designed to be non-inductive, meaning the impedance must be maintained at a constant value of 50 ohms resistive over a specified frequency range. This defines its operating frequencies. Figure 3 shows the measured impedance characteristics from 1 to 150 MHz using an AIM-4170 vector impedance meter.

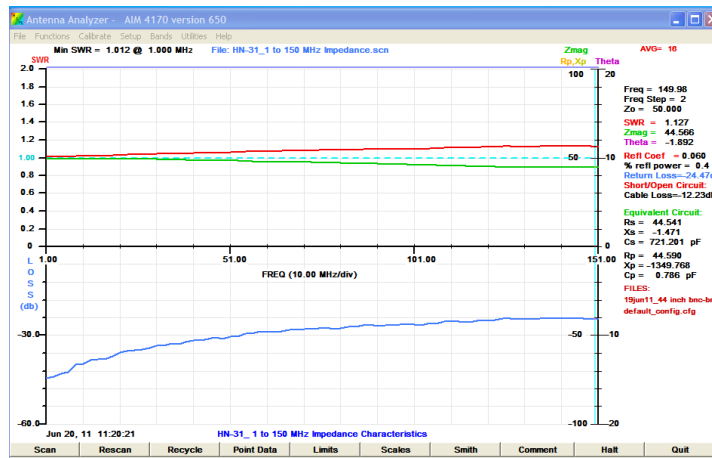

Figure 3
Impedance Plot for the HN-31 Antenna

NOTES on the HEATHKIT HN-31 CANTENNA

The Cantenna performs rather well for the \$10 (1968) investment at that time. The impedance limits seem to be determined by stray capacitance becoming noticeable around 150 MHz.

RESISTOR MANUFACTURERS

The Heathkit HN-31 resistor, part number 1J-2 appears in their manual of 11 / 26 / 65, and later as 1-2-10. It was manufactured by Carborundum. Their part number was 218SP-2 and is described as a 50 ohm +/-10%, ceramic tube, non-inductive resistor. There is no longer any reference to this product on the Carborundum website. Of course, "genuine" Heathkit parts are unavailable for repairs now as well.

Figure 4 is a sketch of the construction and size of this remarkable resistor.

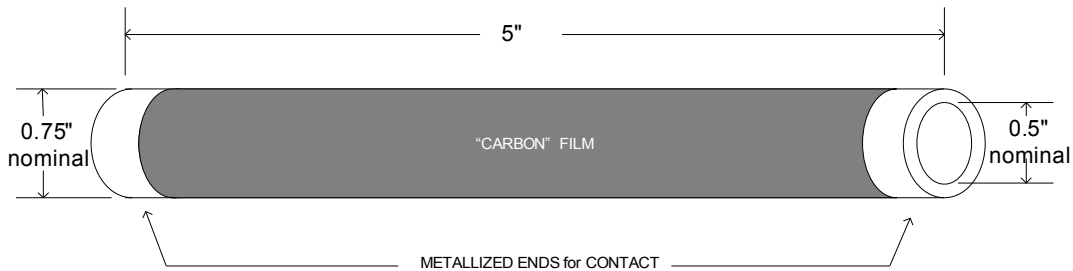

Figure 4
Ceramic Resistor Physical

Kanthal Global, Reference 2 and 4, apparently purchased Carborundum's Electric Products Division in 1993 and not surprisingly have an identical resistor, their part number 886-SP-500-K where 500 = 50 ohms, K = 10% tolerance with aluminum metalized ends. It is rated at 90watts in free air at 40°C, at which point the surface temperature rises to its maximum specification of 350° C. The SP designation is of prime importance as it indicates that the resistor is specially coated to make it impermeable to cooling fluid ingress. A non-coated version of this resistor (such as type A or AS) will absorb cooling fluids causing a significant increase in resistance (up to 100%). A pricing and availability enquiry sent to sales.globar@kanthal.com resulted in,

2 pieces min order, \$87.50 each. Delivery 8 weeks ARO

Another vendor of ceramic tube resistors, US Resistor, Reference 3, offers resistors of similar construction but there is not an identically sized article (0.75" OD x 0.25" ID x 5" Long) listed. No pricing was requested.

MFJ offers a product very much like the Heathkit Cantenna as the MFJ-250 and also has available various 50 ohm non-inductive resistors as indicated here from their web page.

Search Results		
Matching Part Number or Description		
Item #	Description	Price
115-1500	DUMMY LOAD,90 WATT,50 OHM,10%,RESISTOR,	\$20.16
115-1500A	RESISTOR, 90 WATTS, 10%, OIL TREATED, 50 OHM	\$35.80
113-1220	RESISTOR, DL, 50 OHM, 35W, 10%, VEC	\$22.50
119-1500	RESISTOR, 50 OHM, 200 WATTS, 6~ L X 1~ DIA	\$32.31

Figure 5
MFJ 50 Ohm Load Resistors

NOTES on the HEATHKIT HN-31 CANTENNA

As well, these are the listed resistors as they appeared in the 2009 catalog

Non-Inductive Resistors

Fig.	Part No. #	Price	Resistance	Rating	Diameter	Length
A*	115-5800	\$3.00	50 Ohm	50 Watts	1/2x1/2 in.	2.0 inches
B	113-1220	\$22.50	22 Ohm	35W cont.	3/4 inches	2.5 inches
B	113-1350	\$22.50	35 Ohm	35W cont.	3/4 inches	2.5 inches
B	113-1450	\$15.00	45 Ohm	35W cont.	3/4 inches	2.5 inches
B	113-2100	\$22.50	100 Ohm	35W cont.	3/4 inches	2.5 inches
C	115-1500	\$20.16	50 Ohm	90W cont.	3/4 inches	5 inches
D	119-1500	\$32.31	50 Ohm	200W cont.	1 inch	6 inches
E	755-3080	.75				
F	755-4100	2.76				

Terminal clip for 3/4" dummy load resistor, requires 2 per resistor. Terminal clip for 1" dummy load resistor, requires 2 per resistor.

*Item A is an RCD 620, wire wound. Solder terminals attached, 2 mounting holes.

Figure 6
MFJ Catalog Listing

The 115-1500A, an oil treated resistor, Reference 4, immersion ready, would appear to be a replacement for the Heathkit resistor at 0.75" OD x 5". DO NOT USE the 115-1500. The following is a response from MFJ regards use of their resistor in the Heathkit Cantenna.

Ticket #5114167 - va7jw@shaw.ca

MFJ 115-1500A 50 ohm non-inductive dummy load resistor

Are you able to advise if the 115-1500A resistor is a direct replacement for the 50 ohm non inductive resistor used in the old Heathkit HN-31 product? Thanks

Response to Question

yes, it is an oil-treated resistor used in our mfj-250 products. the mfj-250 was a direct clone of the heathkit. thanks for your business.

Transformer oil is sold under part number MFJ-21.

MFJ-21	OIL, GALLON FOR 250 DUMMY LOAD	\$29.95
--------	--------------------------------	---------

COOLANTS

The 50 ohm resistor is immersed in an oil that keeps the temperature of the resistor within its' safe operating limits. Two types of oil can be used, Mineral oil or Transformer oil.

Mineral oil is a colorless, transparent, odorless, liquid produced as a byproduct from the distillation of petroleum. It is referred to as Mineral oil because it is NOT a vegetable oil. Mineral oil has many uses in the food and medical industry as it is non-toxic. In the electrical industry it is used extensively as it has very high dielectric strength (non-conductive), is stable under high temperatures and has excellent thermal properties making it very useful as a coolant.

Transformer oil is a highly refined mineral oil which improves the insulating properties and fits the requirements for the dummy load.

NOTES on the HEATHKIT HN-31 CANTENNA

Prior to 1980, transformer oils contained carcinogenic PCB's and if in doubt about the oil in an older load, dispose of the oil immediately and responsibly, and replace with new oil.

Another less common is oil is Silicone Transformer Oil, a Polydimethylsiloxane fluid formulated specifically for use as a dielectric coolant in electrical transformers. It is characterized by its high dielectric strength, wide service temperature range, and inflammability. It is not readily available to the consumer and is costly.

OTHER OILS ARE NOT TO BE SUBSTITUTED. For instance, motor oil can withstand very high temperatures but it is optimized to perform as a lubricant and so is sticky and has a very different viscosity not well suited for the heat removal process. Do NOT use anything other than the recommended coolants.

Both mineral and transformer oils are volatile; they can form flammable vapors when heated excessively. However, transformer oil is treated with additives to ensure that it does not readily burn. Mineral oil, while not similarly treated, is not considered highly flammable. Obviously for safety reasons, treat all oils with care in this regard.

An important property of the oil is the Flash Point. This is the point at which a volatile liquid will vaporize within the liquid, forming bubbles. These vapors may form an ignitable gas when mixed with air (oxygen). They may burn or explode if there is an ignition source (open flame / spark) in the vicinity. If vapors are produced in the dummy load, they are contained within the pail but there is a pressure relief valve in the lid which can release vapors to the surrounding atmosphere.

Reviewing various specifications (Materials Safety Data Sheets, "MSDS") on the web and comparing manufacturers spec sheets based on the use and application, the following condensed data describe the nominal properties.

PROPERTY	MINERAL	TRANSFORMER	SILICONE
Appearance	Crystal Clear	Clear Brown	Crystal Clear
Odor	None	Mild petroleum	Unknown
Flash Point	> 140 °C	> 140 °C	> 200 °C
Breakdown Voltage	30 kV *	> 60 kV	> 50kV
Flammability	Slight	Slight	Non flammable

Table 1
Some Properties of Recommended Coolant Oils

* Pure white, light mineral oil is typically specified as food or medical grade and dielectric strength is not a requirement. However it greatly exceeds voltages found in 1500 W dummy load applications, i.e. 500V or so.

HEAT FLOW

The heat developed in the resistor has to be carried away by the liquid oil that immerses the resistor. It is this convective cooling that maintains the resistor surface temperatures at a manageable level. Correspondingly, there is a power / time de-rating curve printed on the side of the pail as the load cannot dissipate 1 kW for very long. Heathkit optimistically specifies that it can dissipate 200 watts continuously but this reduces as power is increased above that. At the 1 kW level, the maximum CW power "on" time is optimistically 10 minutes. The spec. does not mention how hot it is allowed to get. The dummy load must be allowed to cool between high power "on" times.

Attention MUST therefore be paid to the build up of heat in the dummy load. The surface temperature of the pail is not a particularly good indication as to what the temperatures are within

NOTES on the HEATHKIT HN-31 CANTENNA

the liquid and on the resistor surface. Too high a temperature can cause the resistor to become impaired by scorching of the resistive film or failure due to cracking of the ceramic dielectric.

In order for heat to flow from the resistor surface into the liquid there has to be a temperature difference between the resistor surface and the liquid in contact with the surface. The greater the temperature differential, the greater will be the rate of heat flow. When heat is being produced at the kW level, this differential will be high leading to high surface temperatures on the resistor.

The 1 gallon mass of oil heats up rather rapidly at the kW level and in turn it can only dissipate that heat by convecting it to the inside surface of the pail. The outside surface of the pail is not an efficient radiator of heat and so this limits the ability of the load to cool itself. A thermal profile was observed on the side of the pail as per Figure 7 as it was heating up from room temperature. This measurement was performed with an IR thermometer.

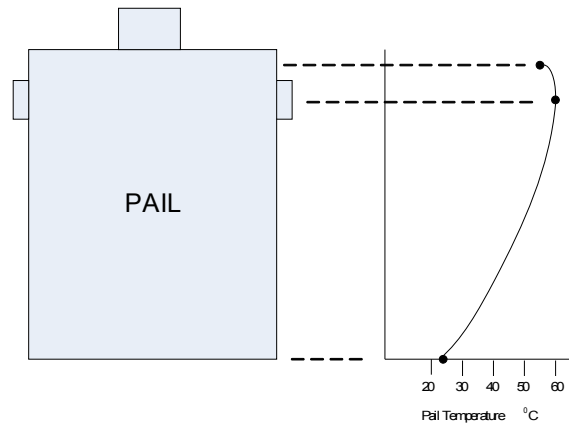

Figure 7
Temperature Profile of Pail When Heating Up

As a scenario, the surface temperature of the resistor may exceed the flash point of the liquid when heat is being produced faster than the conductive and convection action of the liquid can carry it away. For instance, if a series of high power tests is being conducted, resistor surface temperatures in excess of 150 degrees can be easily reached. Vapor bubbles may form at the surface of the resistor. At the outset, it is likely they condense quickly as they leave the resistor surface and enter a cooler liquid regime. However, if the heat cannot be removed quickly enough and vapor production becomes intense, it is possible that the surface of the resistor will become surrounded by vapor thus rapidly decreasing the cooling ability of the liquid. The surface temperature could quickly rise as a result inducing a resistor failure.

The OIL MUST NEVER BE ALLOWED TO BOIL.

Clearly it is necessary to keep the temperature of the dummy load under control by limiting the duration of applied power at whatever level. As there is no direct way to measure the resistor temperature, MONITOR THE TEMPERATURE AT THE TOP OF THE PAIL; this is the hottest area. Do not let it exceed about 50 °C. You can use the “Rule of Thumb” in this regard as 50 °C is about the upper tolerable limit and so if you cannot hold your thumb on the lid for more than 1 second; that is TOO HOT in this writers opinion.

RESISTANCE CHANGE with TEMPERATURE

All resistors have a temperature coefficient, that is, the resistance changes with temperature, usually increasing with higher temperature. Typically this is not much of a problem as resistor values as used in electronic circuits are seldom subjected to temperatures beyond 50 °C.

NOTES on the HEATHKIT HN-31 CANTENNA

However, the dummy load resistor operates under far more duress due to its function, which is to purposely dissipate power, and in this design, lots of it.

The tempco for Global resistors of the SP type is between +0.2% to - 0.08% / degree C, That means the resistance may either increase or decrease with temperature. For a 50 ohm resistor this would be + 0.1 ohm or - 0.04 ohm per degree C. The max permitted surface temperature is 350 °C. At +350 degrees, the temperature rise above an ambient of 20 degrees C would be 330 degrees and the resistance could range from 83 ohms to 37 ohms.

The US Resistor tempco's has a tempco specified at up to -0.13% / degree C which is - 0.065 ohm per degree C. Assuming their resistors behave similarly to Global product, a 330 degree rise in temperature could see the resistance decrease to 29 ohms.

Neither of these scenarios would be typical of actual performance. Still, this resistor is subject to great changes in temperature, and it may be that the nominal 50 ohms is different at elevated temperatures, such that the accuracy of power readings may well be affected. This possibility was investigated.

RESISTANCE MEASUREMENT

Measurement of the resistance of a "hot" Cantenna gave unexpected results. DC resistances were measured anywhere from 40 ohms to 20 ohms with various DVM's. One DVM even registered a negative resistance. As the Cantenna cooled, the resistance returned to the nominal 50 ohm level. A second Cantenna was secured and put to the same tests, ~ 1 kW for a few minutes until the top of the pail was quite hot to the touch. Same results.

This turned out to be an instrumentation / measurement problem due to the thermoelectric effect caused by dissimilar metals in contact with each other, and at differing temperatures, which will generate a small but measurable voltage. Given the various metallic connections between the resistor and other parts of the dummy load (Figure 1) plus the considerable temperature differential generated from the hot end (top) of the resistor compared to the bottom end (cold) with the load under power (Figure 7), a complex voltage regime is developed with a net result that DC voltages in the 10's of mV are generated.

If interested, measure the DC voltage at the SO-239 connector when the load is completely at room temperature. There was less than 50 uV of thermal voltage using a Fluke Model 73 on the 300 mV range. At elevated temperature, where there are significant temperature differences throughout the "system", there is over 20 mV of thermal voltage present. The load has become a voltage source. As the load cools down, watch the voltage decrease to less than measurable over a period of a few hours as the load returns to thermal equilibrium at room temperature.

How does this corrupt the DVM measurements? DVM's source a known amount of current and measure the voltage across the unknown resistance and then calculate the resistance in ohms. DVM's do not source a "standard" current. The currents sourced with the authors various DVM's produced voltages across the 50 ohm load ranging from 22 mV to 120mV. The swamping of the DVM generated voltage by the thermoelectric voltage accounts for the wildly varying readings so obtained. An old fashioned VOM of 10k/volt will give a more accurate reading than a DVM since the VOM applies ~ 1.5 volts to the resistor under test.

An AC impedance measurement will ignore the DC voltages and give a correct reading. The impedance of the load was measured with an AIM 4170 Vector Impedance Meter which sweeps an RF signal voltage across the dummy load at approximately 35 mVAC as measured with a 'scope. This is an AC measurement and the DC thermal voltages do NOT affect the impedance measurement. The first sweep is performed at a room temperature of 21 °C. The dummy load is subjected to about 200 watts for about 5 minutes such that the pail temperature measured near

NOTES on the HEATHKIT HN-31 CANTENNA

the top rises above 60 °C. Figure 8 shows the results of such a measurement over the HF, 1 to 30 MHz spectrum.

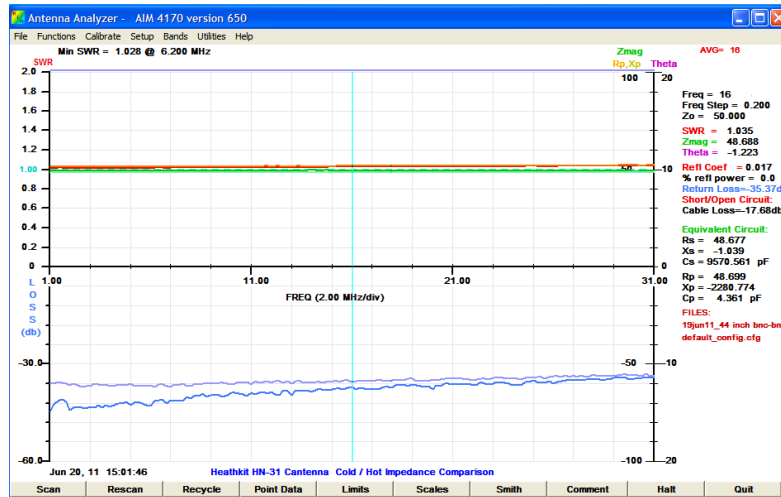

Figure 8
Impedance of the Dummy Load at 21 and 60+ °C from 1 MHz to 30 MHz

As can be seen, the SWR and Z plots overlay each other. The Return Loss does change a few dB for the worse but at 35 dB overall this is not an issue.

CONCLUSIONS

The venerable Heathkit HN-31 at 43 years old still performs as well as it ever did, and that performance is excellent.

The resistance of this dummy load resistor at 49.4 ohms is amazingly good after the uncountable heating and cooling cycles it has been through. The unpublished spec. is +/- 10%.

The impedance of the load is very stable with temperature and the temperature coefficient of the resistor does not appear to cause any significant accuracy of power measurement change due to a deviation from 50 ohms.

Measuring the DC resistance can only be done when the load is at thermal equilibrium, that is, when the temperature of all components are the same throughout the system. This would be the case when the load is allowed to rest at room temperature for at least 4 hours after being used (heated).

To be certain, use a sensitive 3-1/2 digit DVM with a 200 MV scale setting and measure the DC voltage at the SO-239. It should read 000.0 mV.

Acknowledgements

Thanks to Ted Ball, ex-VE6PQ for his technical expertise in sorting out the DC measurement dilemma. He first suggested that thermoelectric voltages might be causing the errors in the hot resistance measurements. He was, as usual, spot on as confirmed with subsequent measurements.

NOTES on the HEATHKIT HN-31 CANTENNA

References

Ref 1. Heathkit Manual

<http://www.repeater-builder.com/heath/hn-31-cantenna.pdf>

Ref 2. Kanthal – Global. Technical specifications for the power resistor

<http://www.global.com/pdfs/Series-800-1000-Tubular.pdf/>

Ref 3 US Resistor

<http://www.usresistor.com/materials.html>

Ref 4. Comments on Oil Impregnation

http://groups.google.com/group/rec.radio.amateur.antenna/browse_thread/thread/ade0d34449ff70a2

Ref 5. Article on the HN-31

http://www.w6ze.org/Heathkit/Heathkit_020_HN31.pdf

Permissions

This article may be used by other amateurs for their personal information.

This material may not be used by persons for monetary gain

Permission to quote is granted provided credit is given as to this source.

Correspondence may be addressed to the author,

John White VA7JW
344 Oxford Drive
Port Moody, BC
Canada
V3H 1T2

va7jw@shaw.ca

604-936-2367

Copyright February 2012 ©

Revision 1 Changes, 21 Feb 2012

NOTES on the HEATHKIT HN-31 CANTENNA

1. Added max power rating (90watts – 40° C air) for the Globar resistor
2. Inserted date for the banning of PCB transformer oils as 1980.
3. Corrected typo under Resistance Measurement to read “This is an AC measurement and the DC thermal voltages do **NOT** affect the impedance measurement.”
4. BOLDED various cautionary advisements
5. Updated link to W6ZE
6. Minor editorial changes